

**TM 5-3805-380-10**

---

TECHNICAL MANUAL

**OPERATOR'S MANUAL  
FOR  
HIGH SPEED SELF-PROPELLED  
COMPACTOR**

**CATERPILLAR MODEL 815F  
NSN 3805-01-431-8439  
END ITEM CODE (EIC) E5E**

**DISTRIBUTION STATEMENT A: Approved for public release; distribution is unlimited.**

---

**HEADQUARTERS, DEPARTMENT OF THE ARMY**  
AUGUST 1999



## Important Safety Information

### HEAT AND COLD STRESS:

### **WARNING**

Since the Compactor is not equipped with an enclosed cab, air conditioner, or personnel heater, all personnel operating the Compactor in hot or cold climates must be familiar with the symptoms of heat/cold stress. Refer to TB MED 507, Heat Injury Prevention, Treatment, and Control; TB MED 81, Cold Injury; and FM 21-10, First Aid for Soldiers, for guidelines to avoid heat/cold stress and follow the recommended work/rest cycles for specific conditions detailed therein.

### NOISE LEVEL HAZARD:

Personnel hearing can be PERMANENTLY DAMAGED if exposed to constant high noise levels of 85dB(A) or greater. Wear approved hearing protection devices when working on and around the Compactor during operation. Personnel exposed to high noise levels shall participate in a hearing conservation program in accordance with TB MED 501, Noise and Conservation of Hearing. Hearing loss occurs gradually but becomes permanent over time.

### VIBRATION DANGER:

### **WARNING**

Operators can safely run the High Speed, Self-Propelled, Compactor 7 ½ to 12 ½ hours per day. In fact, even longer periods are safe, however, NEVER exceed 17 hours at a stretch. This could cause vibration injury to personnel. Additionally, DO NOT exceed a speed of 3 miles per hour when operation this equipment.

### FUEL CAP:

The Compactor is not equipped with a vented fuel cap. If the Compactor sits for long periods of time, without operating, pressure may buildup in the system resulting in a fuel leak. To prevent this from occurring, it is recommended that the fuel cap be opened at least once a month to release the pressure in the system.

## Important Safety Information

### WARNING

**Improper operation, lubrication, maintenance or repair of this product can be dangerous and could result in injury or death.**

**Do not operate or perform any lubrication, maintenance or repair on this product, until you have read and understood the operation, lubrication, maintenance and repair information.**

Safety precautions and warnings are provided in this manual and on the product. If these hazard warnings are not heeded, bodily injury or death could occur to you or other persons.

The hazards are identified by the "Safety Alert Symbol" and followed by a "Signal Word" such as "WARNING" as shown below.

### WARNING

**The meaning of this safety alert symbol is as follows:**

**Attention! Become Alert! Your Safety is Involved.**

The person servicing the product may be unfamiliar with many of the systems on the product. This makes it important to use caution when performing service work. A knowledge of the system and/or components is important before the removal or disassembly of any component.

Because of the size of some of the product components, the service person should check the weights noted in this manual. Use proper lifting procedures when removing any components.

Following is a list of basic precautions that should always be observed.

#### Safety Signs

Read and understand all Warning signs on the product before operating, lubricating or repairing this product. Replace any damaged, illegible or missing warning plates, signs or decals.

#### Protective Equipment

Always wear a hard hat, protective glasses, protective shoes and other protective equipment as required by job conditions when working around this product. In particular, wear protective glasses when pounding on any part of the product or its attachments with a hammer or sledge. Use welder's gloves, hood/goggles, apron and other protective clothing appropriate to the welding job being performed. Do not wear loose clothing or jewelry that can catch on parts of the product.

#### Pressurized Items

1. Relieve all pressure in air, oil or water systems before any lines, fittings or related items are disconnected or removed. Always make sure all raised components are blocked correctly and be alert for possible pressure when disconnecting any device from a system that utilizes pressure.
2. Lower the bucket, blade, ripper or other attachments to the ground before performing any work on the machine. If this cannot be done, make sure the bucket, blade, ripper or other attachment is blocked correctly to prevent it from dropping unexpectedly.
3. Loose or damaged fuel, lubricant and hydraulic lines, tubes and hoses can cause fires. Do not bend or strike high pressure lines or install ones which have been bent or damaged. Check lines, tubes and hoses carefully. Do not use your bare hand to check for leaks. Pin hole leaks can result in a high velocity fluid stream that will be invisible close to the hose, tube or line. This fluid can penetrate the skin and cause personal injury. Use a board or cardboard to check for leaks.

#### Mounting and Dismounting

Use steps and handholds when mounting or dismounting a machine. Clean any mud or debris from steps, walkways or work platforms before using. Always face machine when using steps, handholds and walkways. When it is not possible to use the designed access system, provide ladders, scaffolds, or work platforms to perform safe repair operations.

#### Hot Fluids and Parts

1. To avoid burns, be alert for hot parts on machines which have just been stopped and hot fluids in lines, tubes and compartments.
2. Be careful when removing fill caps, breathers and plugs on the machine. Hold a rag over the cap or plug to prevent being sprayed or splashed by liquids under pressure. The danger is even greater if the machine has just been stopped because fluids can be hot.

#### Lifting

Use a hoist when lifting components which weigh 23 kg (50 lb) or more, to avoid back injury. Make sure all chains, hooks, slings, etc., are in good condition and are in the correct capacity. Be sure hooks are positioned correctly. Lifting eyes are not to be side loaded during a lifting operation.

#### Repair

1. Disconnect battery and discharge any capacitors before starting to work on the product. Attach a "Do Not Operate" tag in the Operator's Compartment.
2. If possible, make all repairs with the machine parked on a level, hard surface. Block machine to prevent it from rolling while working on or under machine.

3. Do not work on any machine that is supported only by lift jacks or a hoist. Always use blocks or jack stands to support the machine before performing any service or disassembly.
4. Be careful when removing cover plates. Gradually back off the last two bolts or nuts located at opposite ends of the cover or device. Then, pry the cover loose to relieve any spring or other pressure, before removing the last two bolts or nuts completely.
5. Always use tools that are in good condition and be sure you understand how to use them before performing any service work.
6. Replace all fasteners with same part number. Do not use a lesser quality fastener if replacements are necessary.
7. Repairs which require welding should be performed only with the benefit of the appropriate reference information and by personnel adequately trained and knowledgeable in welding procedures. Make reference to "Techniques of Structural Repair Course", SEGV2549. Determine type of metal being welded and select correct welding procedure and electrodes, rods or wire to provide a weld metal strength equivalent at least to that of parent metal.
8. Do not damage wiring during removal operations. Reinstall the wiring so it is not damaged nor will it be damaged in operation by contacting sharp corners, or by rubbing against some object or hot surface. Do not connect wiring to a line containing fluid.
9. Be sure all protective devices including guards and shields are properly installed and functioning correctly before starting a repair. If a guard or shield must be removed to perform the repair work, use extra caution. Repair any loose or damaged fluid lines, tubes or hoses because leaks can cause fires.
10. Always use lift arm supports to keep lift arms raised. Keep the attachment tilted down when maintenance or repair work is performed which requires the lift arms in the raised position.
11. Tighten connections to the correct torque. Make sure that all heat shields, clamps and guards are installed correctly to avoid excessive heat, vibration or rubbing against other parts during operation. Shields that protect against oil spray onto hot exhaust components in event of a line, tube or seal failure must be installed correctly.
12. Do not operate a machine if any rotating part is damaged or contacts any other part during operation. Any high speed rotating component that has been damaged or altered should be checked for balance before reusing. Make sure all protective devices including guards and shields are properly installed and functioning correctly, before starting the engine or operating the machine.
13. On track-type machines, be careful when servicing or separating tracks. Chips can fly when removing or installing a track pin. Wear protective glasses. Track can unroll very quickly when separated. Keep away from front and rear of machine. The machine can move unexpectedly when both tracks are disengaged from the sprockets. Block the machine to prevent it from moving. Chips can fly also from bucket or ripper teeth or anywhere a pin is being removed or installed.

#### **Asbestos Information**

Caution should be used to avoid breathing dust that may be generated when handling components containing asbestos fibers. If this dust is inhaled, it can be hazardous to your health. Components in Caterpillar products that may contain asbestos fibers are brake pads, brake band and lining assemblies, clutch plates and some gaskets. The asbestos used in these components is usually bound in a resin or sealed in some way. Normal handling is not hazardous as long as airborne dust which contains asbestos is not generated.

If dust which can contain asbestos is present, there are several common sense guidelines that should be followed.

1. Never use compressed air for cleaning.
2. Avoid brushing or grinding of asbestos containing materials.
3. For clean up, use wet methods or a vacuum equipped with a high efficiency particulate air (HEPA) filter.
4. Use exhaust ventilation on permanent machining jobs.
5. Wear an approved respirator if there is no other way to control the dust.
6. Comply with applicable rules and regulations for the work place (for example in the U.S.A., OSHA requirements as set forth in 29 CFR 1910.1001).
7. Follow environmental rules and regulations for disposal of asbestos.
8. Avoid areas where asbestos particles may be in the air.

**CATERPILLAR®**

Faint, illegible text in the top left section of the page.

Faint, illegible text in the top right section of the page.

Faint, illegible text in the middle left section of the page.

Faint, illegible text in the middle right section of the page.

Faint, illegible text in the bottom left section of the page.

Faint, illegible text in the bottom right section of the page.

Handwritten text at the bottom center of the page, possibly a signature or date.

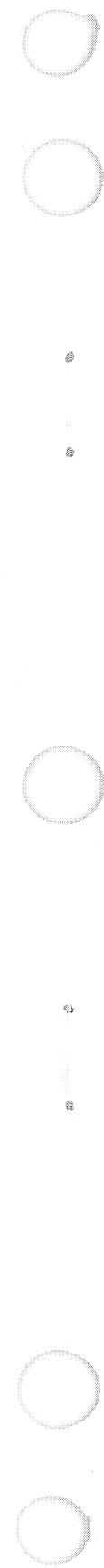

HEADQUARTS,  
DEPARTMENT OF THE ARMY  
Washington D.C., 12 August 1999

**OPERATORS MANUAL  
FOR  
HIGH SPEED, SELF PROPELLED,  
COMPACTOR**

**CATERPILLAR MODEL 815F  
NSN 3805-01-431-8439  
END ITEM CODE (EIC): E5E**

**REPORTING ERRORS AND RECOMMENDING IMPROVEMENTS**

You can help improve this publication. If you find any mistakes or if you know of a way to improve the procedures, please let us know. Submit your DA Form 2028-2 (Recommended Changes to Equipment Technical Publications), through the Internet, on the Army Electronic Product Support (AEPS) website. The Internet address is <http://aeprs.ria.army.mil>. If you need a password, scroll down and click on "ACCESS REQUEST FORM". The DA Form 2028 is located in the ONLINE FORMS PROCESSING section of the AEPS. Fill out the form and click on SUBMIT. Using this form on the AEPS will enable us to respond quicker to your comments and better manage the DA Form 2028 program. You may also mail, fax or email your letter, DA Form 2028, or DA Form 2028-2 direct to: Commander, U.S. Army Tank-automotive and Armaments Command, ATTN: AMSTA-AC-NML, Rock Island, IL 61299-7630. The email address is [amsta-ac-nml@ria.army.mil](mailto:amsta-ac-nml@ria.army.mil). The fax number is DSN 793-0726 or Commercial (309) 782-0726.

**DISTRIBUTION STATEMENT A: Approved for public release; distribution is unlimited.**

**TABLE OF CONTENTS**

| <b>Information Section</b>      |    | <b>General Section</b>                                      |    |
|---------------------------------|----|---|----|
| Information Section             | 1  | Specifications and Model Views                              | 15 |
| Forward                         | 2  | Product Identification, Serial number and CE Plate Location | 16 |
| <b>Safety Section</b>           |    | <b>Operation Section</b>                                    |    |
| Important Safety Information    | 4  | Monitoring System and Cab Features                          | 18 |
| Safety                          | 5  | Machine Controls  | 32 |
| Warning Signs                   | 5  | Attachment Controls   | 36 |
| General Hazard Information      | 7  | Before Starting the Engine                                  | 38 |
| Crushing or Cutting Prevention  | 9  | Engine Starting   | 40 |
| Burn Prevention                 | 9  | Machine Operation   | 44 |
| Fire or Explosion Prevention    | 10 | Operating Techniques  | 46 |
| Mounting and Dismounting        | 12 | Machine Parking   | 53 |
| Before Starting Engine          | 13 | Transportation Information                                  | 55 |
| Engine Starting                 | 13 | Towing Information  | 57 |
| Before Operating the Machine    | 13 |   |    |
| Machine Operation               | 14 |   |    |
| Machine Parking                 | 14 |   |    |
| Sound and Vibration Information | 14 |   |    |

**Maintenance Section**

|   |    |
|---|----|
| Tire Inflation Information                  | 60 |
| Torque Specifications                       | 62 |
| Cooling System Specifications               | 64 |
| Fuel Specifications                         | 73 |
| Scheduled Oil Sampling (SOS)                | 76 |
| Lubrication Specifications                  | 77 |
| Lubricant Viscosities and Refill Capacities | 83 |
| Maintenance Intervals                       | 84 |
| When Required                               | 85 |

|                                      |     |
|--------------------------------------|-----|
| Every 10 Service Hours or Daily      | 95  |
| Every 50 Service Hours or Weekly     | 103 |
| Every 100 Service Hours or 2 Weeks   | 104 |
| Every 250 Service Hours or Monthly   | 107 |
| Every 500 Service Hours or 3 Months  | 116 |
| Every 1000 Service Hours or 6 Months | 122 |
| Every 2000 Service Hours or 1 Year   | 126 |
| Every 3000 Service Hours or 2 Years  | 130 |
| Every 6000 Service Hours or 4 Years  | 132 |

**Literature Reference Section**

|                                |     |
|--------------------------------|-----|
| Literature Reference Materials | 133 |
| Index Section                  | 134 |

**APPENDICES**

|   |   |
|---|---|
| A | Additional Authorized List (AAL)                    |
| B | Interim Support Items List (ISIL)                   |
| C | Approved Fuels, Lubricants, Grease, and Oil         |
| D | Operator Preventive Maintenance Checks and Services |



## HOW TO USE THIS MANUAL

This manual is designed to help operate and maintain the High-Speed Self-Propelled Compactor (NSN 3805-01-431-8439). Listed below are some special features that have been included to help locate and use the needed information.

A front table of contents is provided for quick reference to chapters and sections that will be used often.

Warning, Caution and Note headings, subject headings, and certain other essential information are printed in bold type to make them easier to see.

The maintenance tasks describe what must be done to the compactor before starting the task and what must be done to return the compactor to operating condition after the task is finished.

The appendices are located at the end of the manual. They contain a reference guide to other manuals, and other material for maintaining the compactor.

This manual is directed at the crew/operator of the compactor. It includes an overall description of the compactor and discusses the controls and indicators, their location and use, the instructions for operation of the compactor under different circumstances, preventive maintenance checks and services, basic trouble shooting, and crew operator maintenance.

### FOLLOW THESE GUIDELINES WHEN USING THIS MANUAL:

- The operator must read this manual and become familiar with the contents before attempting to operate the compactor.
- Read all **WARNINGS** and **CAUTIONS** before performing any procedure.
- The equipment conditions found in the maintenance procedure are of a general nature and the operator/crew may be able to perform only certain tasks within a procedure to accomplish the equipment condition.

#### **Scope:**

This manual contains operation and maintenance instructions for the operator/crew of the High-Speed Self-Propelled Compactor.

facilities, surfaces requiring extensive compaction of rock aggregates, preparation of asphalt cement pavements, dams and embankments.

#### **Description:**

The compactor is a self-propelled; diesel powered tamping machine for high-speed embankment compaction. The compactor consists essentially of a multi-fuel engine, articulated steering, hydraulically controlled strike-off dozer blade, rear wheel oscillation, all wheel tamping feet with replaceable tamping tips and wheel cleaning bars.

#### **MOS Requirements:**

Operator, MOS 62J, General Construction Machine Operator.  
Unit Maintenance, MOS 62B20, Construction Equipment Repair.  
Direct Support/General Support Maintenance, MOS 62B30, Construction Equipment Repair.

#### **Operation Concepts:**

The high-Speed Self-Propelled Compactor will be used in construction applications to compact at high density a full range of soils, except clean sand, and perform limited dozing or "strike off" functions. The compactor will be used in the construction and repair, and/or maintenance of roads and airfields, logistical

#### **Logistics Assistance:**

The U.S. Army Tank-automotive and Armaments Command (TACOM) Logistics Assistance Representatives (LARS), stationed at CONUS and OCONUS locations, are available to give on-site training and/or technical assistance.

## Foreword

### Literature Information

The operation and maintenance manual should be stored in the operator's compartment in the literature holder or seat back literature storage area.

The operation and maintenance manual contains safety, operation, transportation, lubrication and maintenance information.

Some photographs or illustrations in the operation and maintenance manual show details or attachments that can be different from your machine. Guards and covers might have been removed for illustrative purposes.

Continuing improvement and advancement of product design might have caused changes to your machine which are not included in the operation and maintenance manual. Read, study and keep the operation and maintenance manual with the machine.

Whenever a question arises regarding the machine, or the operation and maintenance manual, please consult any Caterpillar dealer for the latest available information.

### Safety

The Safety Section lists basic safety precautions. In addition, this section identifies the text and locations of warning signs used on the machine.

Read and understand the basic precautions listed in the Safety Section before operating or performing lubrication, maintenance and repair on the machine.

### Operation

The operation information is a reference for the new operator and a refresher for the experienced one. This information includes a discussion of gauges, switches, machine controls, attachment controls, transportation and towing information.

Photographs and illustrations guide the operator through correct procedures of checking, starting, operating and stopping the machine.

Operating techniques outlined in the operation and maintenance manual are basic. Skill and techniques develop as the operator gains knowledge of the machine and its capabilities.

### Maintenance

The maintenance information is a guide to equipment care. The illustrated, step-by-step instructions are grouped by servicing intervals. Items without specific intervals are listed under When Required topics. Items in the Maintenance Interval Schedule are referenced to detailed instructions that follow.

### Maintenance Interval Schedule

Use the service hour meter to determine servicing intervals. Calendar intervals shown (daily, weekly, monthly, etc.) can be used instead of service hour meter intervals if they provide more convenient servicing schedules and approximate the indicated service hour meter reading. Recommended service should always be performed at the interval that occurs first.

Under extremely severe, dusty or wet operating conditions, more frequent lubrication than is specified in the Maintenance Intervals chart might be necessary.

Perform service on items at multiples of the original requirement. For example, at Every 500 Service Hours or 3 Months, also service those items listed under Every 250 Service Hours or Monthly and Every 10 Service Hours or Daily.

## Machine Description

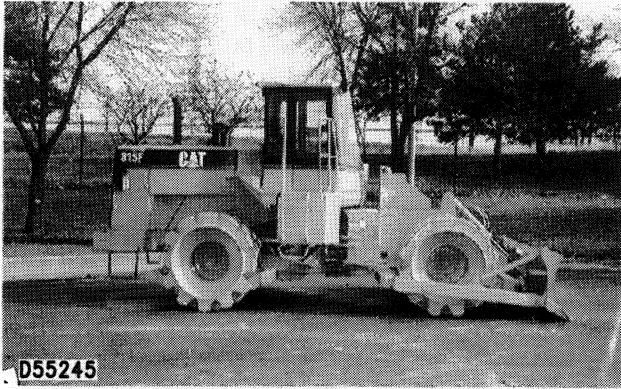

This machine is equipped with a 3306C diesel engine. It has a four-speed transmission and is designed primarily for moving material or compacting operations.

## California

### Proposition 65 Warning

Diesel engine exhaust and some of its constituents are known to the state of California to cause cancer, birth defects, and other reproductive harm.

## Important Safety Information

Most accidents involving product operation, maintenance and repair are caused by failure to observe basic safety rules or precautions. An accident can often be avoided by recognizing potentially hazardous situations before an accident occurs. A person must be alert to potential hazards. This person should also have the necessary training, skills and tools to perform these functions properly.

**Improper operation, lubrication, maintenance or repair of this product can be dangerous and could result in injury or death.**

**Do not operate or perform any lubrication, maintenance or repair on this product, until you have read and understood the operation, lubrication, maintenance and repair information.**

Safety precautions and warnings are provided in this manual and on the product. If these hazard warnings are not heeded, bodily injury or death could occur to you or other persons.

The hazards are identified by the "Safety Alert Symbol" and followed by a "Signal Word" such as "WARNING" as shown below.



The meaning of this safety alert symbol is as follows:

**Attention! Become Alert! Your Safety is Involved.**

The message that appears under the warning, explaining the hazard, can be either written or pictorially presented.

Operations that may cause product damage are identified by NOTICE labels on the product and in this publication.

Caterpillar cannot anticipate every possible circumstance that might involve a potential hazard. The warnings in this publication and on the product are therefore not all inclusive. If a tool, procedure, work method or operating technique not specifically recommended by Caterpillar is used, you must satisfy yourself that it is safe for you and others. You should also ensure that the product will not be damaged or made unsafe by the operation, lubrication, maintenance or repair procedures you choose.

The information, specifications, and illustrations in this publication are on the basis of information available at the time it was written. The specifications, torques, pressures, measurements, adjustments, illustrations, and other items can change at any time. These changes can affect the service given to the product. Obtain the complete and most current information before starting any job. Caterpillar dealers have the most current information available. For a list of the most current publication form numbers available, see the Service Manual Contents Microfiche, REG1139F.

## Safety

### Warning Signs

There are several specific warning signs on this machine. Their exact location and description of the hazard are reviewed in this section. Please become familiarized with all warning signs.

Make sure all warning signs can be read. Clean or replace the warning signs if the words can not be read, or the illustrations are not clear. When cleaning the warning signs, use a cloth, water and soap. Do not use solvent, gasoline, etc., to clean the safety signs. Solvents or gasoline, etc., could loosen the sign adhesive and allow the sign to fall off.

Replace any safety sign if it is damaged, missing or can not be read. If a safety sign is attached to a part that is replaced, make sure a new sign is installed on the replaced part. Contact any Caterpillar dealer for new safety signs.

### WARNING

**Do not operate or work on this machine unless you have read and understand the instructions and warnings in the Operation and Maintenance Manual.**

**Failure to follow the instructions or heed the warnings could result in injury or death.**

**Contact any Caterpillar dealer for replacement manuals. Proper care is your responsibility.**



Located in the operator's compartment.

### WARNING

**Structural damage, an overturn, modification, alteration, or improper repair can impair this structure's protection capability thereby voiding this certification. Do not weld on or drill holes in the structure. Consult a Caterpillar dealer to determine this structure's limitations without voiding its certification.**

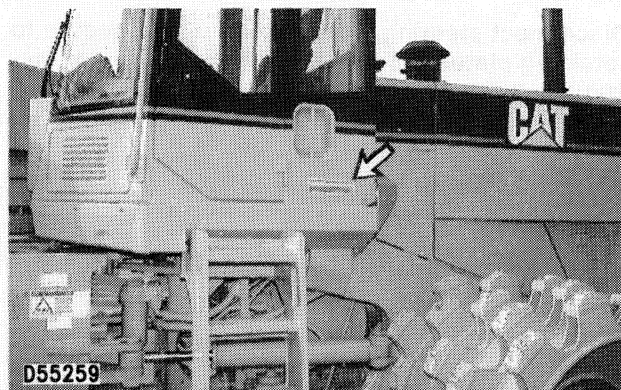

Located on the left side of the cab.

**⚠ WARNING**

No clearance for man in this area when machine turns; Severe injury or death from crushing could occur.

Connect steering frame lock link between front and rear frames before lifting machine, transporting machine on another vehicle, or performing service near center of machine.

Disconnect steering frame lock link and secure to retaining plates before resuming operation or machine will not steer.

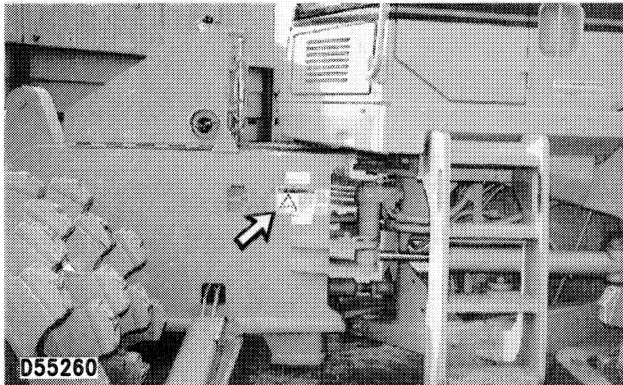

Located on the machine at the center pivot.

**⚠ WARNING**

(Highly compressed spring inside this housing can cause serious physical injury or death. Do not service until you read and understand the information in the service manual for servicing the parking/secondary brake actuator.)



Located on the parking/secondary brake actuator.

**! WARNING**

**Improper jumper cable connections can cause an explosion resulting in personal injury.**

Batteries can be located in separate compartments. When using jump start cables always connect positive (+) cable to positive (+) terminal of battery connected to starter solenoid and negative (-) cable from external source to starter negative (-) terminal. (If machine is not equipped with starter negative terminal, connect to engine block.) Follow the procedure in the operation manual.

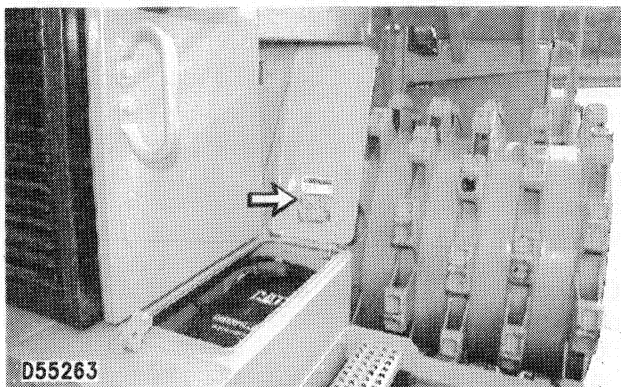

Located on the underside of the battery compartment cover.

**! WARNING**

**Do not step on the cleaner bar when machine is moving.**

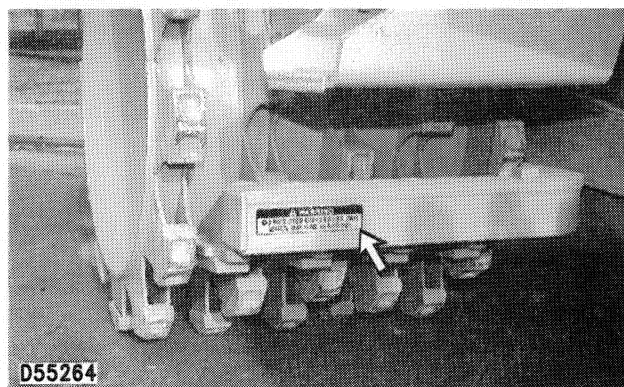

Located on each cleaner bar.

**General Hazard Information**

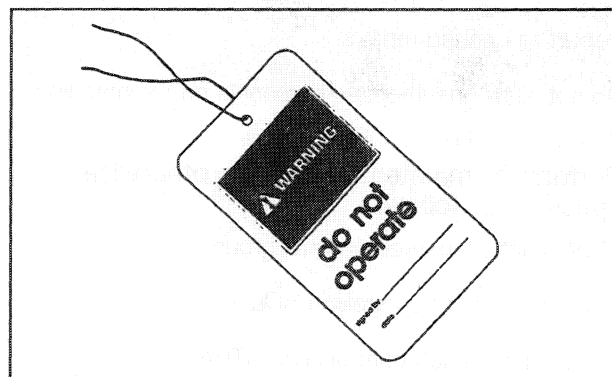

Attach a Do Not Operate, SEHS7332, or similar warning tag to start switch or controls before servicing or repairing the machine. This tag is available from your Caterpillar dealer.

Know the width of your attachments so proper clearance can be maintained when operating near fences, boundary obstacles, etc.

Wear a hard hat, protective glasses and other protective equipment as required by job conditions.

Do not wear loose clothing or jewelry that can catch on controls or other parts of the machine.

Make certain all protective guards and covers are secured in place on the machine.

Keep the machine, especially the deck, walkways and steps, free of foreign material, such as debris, oil, tools and other items which are not part of the machine.

Secure all loose items such as lunch boxes, tools and other items which are not part of the machine.

Know the appropriate work site hand signals and who gives them. Accept signals from one person only.

Inhaling air conditioner refrigerant gas through a lit cigarette or other smoking method or inhaling fumes released from a flame contacting air conditioner refrigerant gas, can cause bodily harm or death. Do not smoke when servicing air conditioners or wherever refrigerant gas may be present.

Never put maintenance fluids into glass containers.

Drain all liquids into a suitable container. Dispose of all liquids according to local regulations.

Use all cleaning solutions with care.

Report all needed repairs.

Do not allow unauthorized personnel on the machine.

**Perform all maintenance unless otherwise specified as follows:**

- The machine parked on level ground.
- The attachment controls in HOLD.
- The transmission control in NEUTRAL.
- The parking brake engaged.
- Lower the blade to the ground and apply slight down pressure.
- The engine stopped.
- The engine start switch key off and the key removed.
- The disconnect switch key off and the key removed.

**Pressure Air**

Pressure air can cause personal injury. When using pressure air for cleaning, wear a protective face shield, protective clothing and protective shoes.

The maximum air pressure must be below 205 kPa (30 psi) for cleaning purposes.

**Fluid Penetration**

Always use a board or cardboard when checking for a leak. Escaping fluid under pressure, even a pin-hole size leak, can penetrate body tissue, causing serious injury, and possible death. If fluid is injected into your skin, it must be treated by a doctor familiar with this type of injury immediately.

**Asbestos Information**

Caterpillar products and replacement parts shipped from Caterpillar are asbestos free. Caterpillar recommends the use of only genuine Caterpillar replacement parts. If any replacement parts containing asbestos are used, the following guidelines should be used in handling these parts and asbestos debris.

Caution should be used to avoid inhaling dust that might be generated when handling components containing asbestos fibers. If this dust is inhaled, it can be hazardous to your health. Components in products that might contain asbestos fibers are brake pads, brake band and lining assemblies, clutch plates and some gaskets. The asbestos used in these components is usually bound in a resin or sealed in some way. Normal handling is not hazardous as long as airborne dust which contains asbestos is not generated.

If dust which can contain asbestos is present, there are several common sense guidelines that should be followed.

- Never use compressed air for cleaning.
- Avoid brushing or grinding of asbestos containing materials.
- For clean up, use wet methods or a vacuum equipped with a high efficiency particulate air (HEPA) filter.
- Use exhaust ventilation on permanent machining jobs.



- Wear an approved respirator if there is no other way to control the dust.
- Comply with applicable rules and regulations for the work place (for example in the U.S.A., OSHA requirements as set forth in 29 CFR 1910.1001).
- Follow environmental rules and regulations for disposal of asbestos.
- Avoid areas where asbestos particles might be in the air.

### Crushing or Cutting Prevention

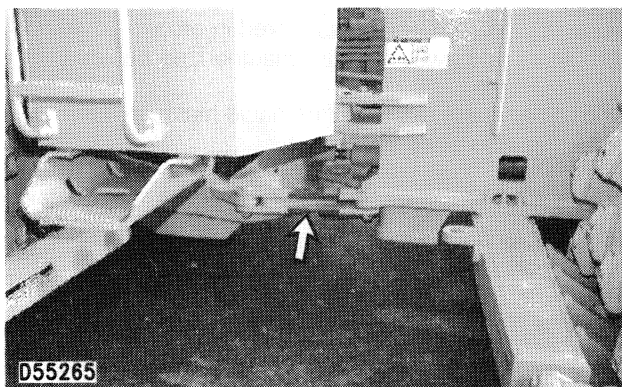

Connect steering frame lock link between front and rear frames before lifting machine, transporting machine on another vehicle, or performing service near center of machine.

Support equipment and attachments properly when working beneath them. Do not depend on hydraulic cylinders to hold them up. An attachment can fall if a control is moved, or if a hydraulic line breaks.

Never attempt adjustments while the machine is moving or the engine is running unless otherwise specified.

Where there are attachment linkages, the clearance in the linkage area will increase or decrease with movement of the attachment.

Stay clear of all rotating and moving parts.

Keep objects away from moving fan blades. They will throw or cut any object or tool that falls or is pushed into them.

Do not use a kinked or frayed wire rope cable. Wear gloves when handling wire rope cable.

Retainer pins, when struck with force, can fly out and injure nearby persons. Make sure the area is clear of people when driving retainer pins.

Wear protective glasses when striking a retainer pin to avoid injury to your eyes.

Chips or other debris can fly off objects when struck. Make sure no one can be injured by flying debris before striking any object.

### Rollover Protective Structure (ROPS) or Falling Objects Protective Structure (FOPS)

ROPS or FOPS is a guard located above the operator's compartment and secured to the machine.

To avoid possible weakening of the ROPS or FOPS, consult a Caterpillar dealer before altering, by adding weight to, welding on, or cutting or drilling holes into the structure.

Any alteration not specifically authorized by Caterpillar invalidates Caterpillar's ROPS and FOPS certification. The protection offered by this ROPS/FOPS will be impaired if it has been subjected to structural damage. Structural damage can be caused by an overturn accident, by falling objects, etc.

Do not mount any item such as fire extinguishers, first aid kits and lights by welding brackets to or drilling holes in any ROPS/FOPS structure. See your Caterpillar dealer for mounting guidelines.

### Burn Prevention

#### Coolant

At operating temperature, the engine coolant is hot and under pressure. The radiator and all lines to heaters or the engine contain hot coolant or steam. Any contact can cause severe burns.

Steam can cause personal injury.

Check the coolant level only after the engine has been stopped and the filler cap is cool enough to remove with your bare hand.

Remove the cooling system filler cap slowly to relieve pressure.

**10**  
**Safety Section**  
**Safety**

Cooling system additive contains alkali that can cause personal injury. Avoid contact with the skin, eyes and mouth.

Allow cooling system components to cool before draining.

**Oils**

Hot oil and components can cause personal injury. Do not allow hot oil or components to contact the skin.

At operating temperature, the hydraulic tank is hot and can be under pressure.

Remove the hydraulic tank filler cap only after the engine has been stopped and the filler cap is cool enough to remove with your bare hand.

Remove the hydraulic tank filler cap slowly to relieve pressure.

Relieve all pressure in air, oil, fuel or cooling systems before any lines, fittings or related items are disconnected or removed.

**Batteries**

Batteries give off flammable fumes which can explode.

Do not smoke when observing the battery electrolyte levels.

Electrolyte is an acid and can cause personal injury if it contacts skin or eyes.

Always wear protective glasses when working with batteries.

**Fire or Explosion Prevention**

All fuels, most lubricants and some coolant mixtures are flammable.

Fuel leaked or spilled onto hot surfaces or electrical components can cause a fire.

Do not smoke while refueling or in a refueling area.

Do not smoke in areas where batteries are charged, or where flammable materials are stored.

Batteries can be located in separate compartments. When using jump start cables always connect positive (+) cable to positive (+) terminal of battery connected to starter solenoid and negative (-) cable from external source to starter negative (-) terminal. (If not equipped with starter negative (-) terminal, connect to engine block.)

See the Operation Section of this manual for specific starting instructions.

Clean and tighten all electrical connections. Check daily for loose or frayed electrical wires. Have all loose or frayed electrical wires tightened, repaired or replaced before operating the machine.

Keep all fuels and lubricants stored in properly marked containers and away from all unauthorized persons.

Store all oily rags or other flammable material in a protective container.

Do not weld or flame cut on pipes or tubes that contain flammable fluids. Clean them thoroughly with nonflammable solvent before welding or flame cutting on them.

Remove all flammable materials such as fuel, oil and other debris before they accumulate on the machine.

Do not expose the machine to flames, burning brush, etc., if at all possible.

Shields, which protect hot exhaust components from oil or fuel spray in the event of a line, tube or seal failure, must be installed correctly.

## Fire Extinguisher

Have a fire extinguisher available and know how to use it. Inspect and have it serviced as recommended on its instruction plate.



The recommended place to mount a fire extinguisher is on the radiator guard portion of the tilt hood at the rear of the machine. Do not weld on or drill holes in the ROPS structure to mount the fire extinguisher on the ROPS.

A fire extinguisher can be mounted to the ROPS legs, by strapping the mounting plate to the leg. Keep the fire extinguisher over 4.5 kg (10 lb) size, as low as possible on one leg. But, never mount it in the top one-third length of the leg.

## Ether

Ether is poisonous and flammable.

Inhaling ether vapors or repeated contact of ether with skin can cause personal injury.

Use ether only in well-ventilated areas.

Do not smoke while changing ether cylinders.

Use ether with care to avoid fires.

Do not store replacement ether cylinders in living areas or in the operator's compartment.

Do not store ether cylinders in direct sunlight or at temperatures above 40°C (102°F).

Discard cylinders in a protective place. Do not puncture or burn cylinders.

Keep ether cylinders out of the reach of unauthorized personnel.

## Lines, Tubes and Hoses

Do not bend or strike high pressure lines. Do not install bent or damaged lines, tubes or hoses.

Repair any loose or damaged fuel and oil lines, tubes and hoses. Leaks can cause fires. Contact your Caterpillar dealer for repair or replacement.

Check lines, tubes and hoses carefully. Do not use your bare hand to check for leaks. Use a board or cardboard to check for leaks. See Fluid Penetration in the Safety Section for more details. Tighten all connections to the recommended torque. Replace if any of the following conditions are found.

- End fittings damaged or leaking.
- Outer covering chafed or cut and wire reinforcing exposed.
- Outer covering ballooning locally.
- Evidence of kinking or crushing of the flexible part of hose.
- Armoring embedded in the outer cover.
- End fittings displaced.

Make sure that all clamps, guards and heat shields are installed correctly to prevent vibration, rubbing against other parts, and excessive heat during operation.

## Tire Information

Explosions of air inflated tires have resulted from heat-induced gas combustion inside the tires. The heat, generated by welding or heating rim components, external fire, or excessive use of brakes can cause gaseous combustion.

A tire explosion is much more violent than a blowout. The explosion can propel the tire, rim and axle components as far as 500 m (1500 ft) or more from the machine. Both the force of the explosion and the flying debris can cause personal injury or death, and property damage.

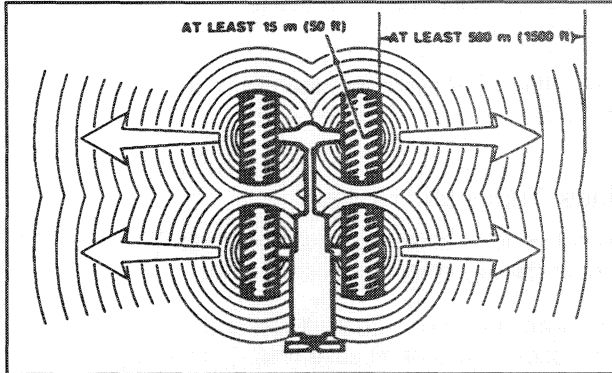

Do not approach a warm tire closer than the outside of the area represented by the shaded area in the illustration.

Dry nitrogen ( $N_2$ ) gas is recommended for inflation of tires. If the tires were originally inflated with air, nitrogen is still preferred for adjusting the pressure. Nitrogen mixes properly with air.

Nitrogen inflated tires reduce the potential of a tire explosion, because nitrogen does not support combustion. Also, nitrogen helps prevent oxidation and the resulting deterioration of rubber and corrosion of rim components.

Proper nitrogen inflation equipment and training in its use are necessary to avoid overinflation. A tire blowout or rim failure can result from improper or misused equipment.

Stand behind the tread and use a self-attaching chuck when inflating a tire.

Servicing and changing tires and rims can be dangerous and should be done only by trained personnel using proper tools and procedures. If correct procedures are not followed while servicing tires and rims, the assemblies could burst with explosive force and cause serious personal injury or death. Follow carefully the specific information provided by your tire or rim servicing personnel or dealer.

## Mounting and Dismounting



- Mount and dismount the machine only where steps and/or handholds are provided.

- Inspect, and when necessary, clean and have repairs made to steps and handholds before mounting and dismounting.

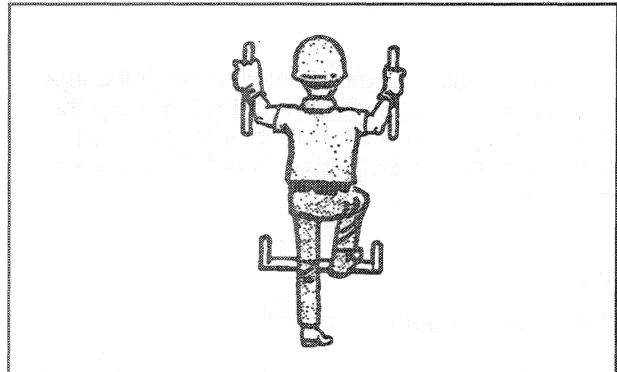

- Face the machine when mounting and dismounting.

- Maintain a three-point contact (two feet and one hand or one foot and two hands contact) with the steps and handholds.

- Never get on or off a moving machine.

- Never jump off the machine.

- Do not try to climb on or off the machine when carrying tools or supplies. Use a hand line to pull equipment up onto the platform.

- Do not use any controls as handholds when entering or leaving the operator's station.

## Alternate Exit

Machines equipped with cabs are equipped with alternate exits. For additional alternate exit information, refer to topic Alternate Exit in the Monitoring Systems and Cab Features section of this manual.

## Before Starting the Engine

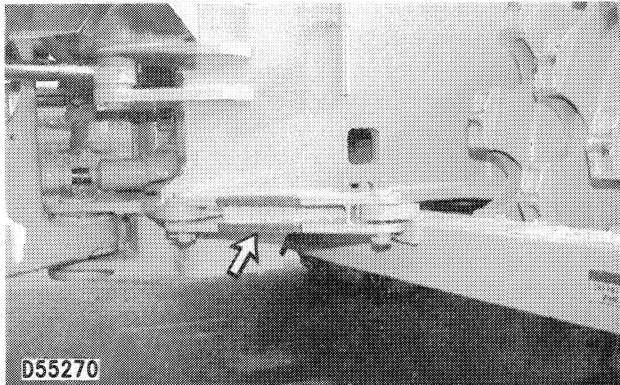

Make sure the steering frame lock link is stored in the unlocked position as shown. The steering frame lock link must be removed to steer the machine.

Start the engine only from the operator's station. Never short across the starter terminals or across the batteries, as this could bypass the engine neutral-start system as well as damage the electrical system.

Inspect the condition of the seat belt and mounting hardware. Replace any damaged or worn parts. Replace the seat belt regardless of appearance, after three years of use. Do not use a seat belt extension on a retractable seat belt.

Adjust the seat so that full pedal travel can be obtained with the operator's back against the seat back.

Make sure the machine is equipped with a lighting system as required by conditions.

Make sure all lights are working properly.

Make sure no one is working on, underneath or close to the machine before starting the engine or beginning to move the machine. Make sure the area is free of personnel.

## Engine Starting

Do not start the engine or move any of the controls if there is a Do Not Operate or similar warning tag attached to the start switch or controls.

Move all hydraulic controls to the HOLD position before starting the engine.

Move the transmission control lever to NEUTRAL.

Engage the parking brake.

Diesel engine exhaust contains products of combustion which can be harmful to your health. Always start and operate the engine in a well-ventilated area. If in an enclosed area, vent the exhaust to the outside.

## Before Operating the Machine

Clear all personnel from the machine and the area.

Clear all obstacles from the path of the machine. Beware of hazards such as wires, ditches, etc.

Be sure all windows are clean. Secure the doors and windows in either the open or shut position.

Adjust the rear view mirrors (if equipped) for best vision, especially close to the machine.

Make sure the machine horn, the backup alarm (if equipped) and all other warning devices are working properly.

Fasten the seat belt securely.

## Machine Operation

Operate the machine only while seated and with the seat belt fastened.

Operate the controls only with the engine running.

Check for proper operation of all controls and protective devices while moving slowly in an open area.

The operator must be satisfied that no one will be endangered before moving the machine.

Do not allow riders on the machine unless additional seat, seat belt and Rollover Protective Structure (ROPS) are provided.

Report any needed repairs noted during operation.

Carry attachments close to the ground, approximately 40 cm (15 in) above ground level.

Stay an adequate distance from the edge of cliffs, overhangs and slide areas.

If the machine begins to sideslip on a grade, immediately dispose of the load and turn the machine downhill.

Be careful to avoid the condition which could lead to tipping when working on hills, banks or slopes, and when crossing ditches, ridges or other obstructions.

Work up and down slopes, rather than sideways, whenever possible.

Keep the machine under control and do not work it over its capacity.

Be sure hitch points and the towing device are adequate.

Connect trailing equipment to a drawbar or hitch only.

Never straddle a wire rope cable or similar device, nor allow others to do so.

No personnel should be between the machine and trailing equipment when maneuvering to connect them. Block the tongue or hitch of trailing equipment to align it with the drawbar or hitch.

Know the maximum height and reach of your machine.

Always keep the Rollover Protective Structure (ROPS) installed (if equipped) when operating the machine.

## Machine Parking

Park on a level surface. If necessary to park on a grade, block the machine.

Apply the service brake to stop the machine.

Move the transmission control lever to NEUTRAL and the speed control to LOW IDLE.

Engage the parking brake.

Lower all attachments to the ground.

Stop the engine.

Turn the engine start switch key to OFF and remove.

Turn the battery disconnect switch key to OFF and remove the key when leaving the machine for an extended period of a month or longer. This will prevent battery drain by short circuits or current draw made by some of the components, or by vandalism.

## Sound and Vibration Information

### Sound Level for Enclosed Cab

The operator sound pressure level for this machine with a properly installed and maintained closed cab configuration is 75 dB (A).

Measurement is obtained on a static machine with the procedures and cab conditions as described in ISO 6394 or 86/662/EEC.

### Vibration Level

Hands/Arms: The weighted root mean square acceleration to which the hands/arms are subjected, is less than 2.5 m/s<sup>2</sup>.

Whole Body: The weighted root mean square acceleration to which the whole body is subjected is less than 0.85 m/s<sup>2</sup>.

Measurements are obtained on a representative machine, using measuring procedures as set forth in the following standards: ISO 2631/1, ISO 5349, and SAE J1166.

## Specifications and Model Views

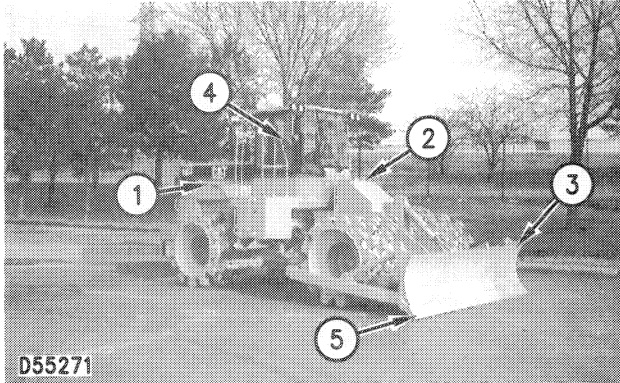

Engine (1), fuel tank (2), bulldozer or landfill blade (3), operator's compartment (4), and cutting edge and end bits (5).



Basic machine shipping specifications are listed below.

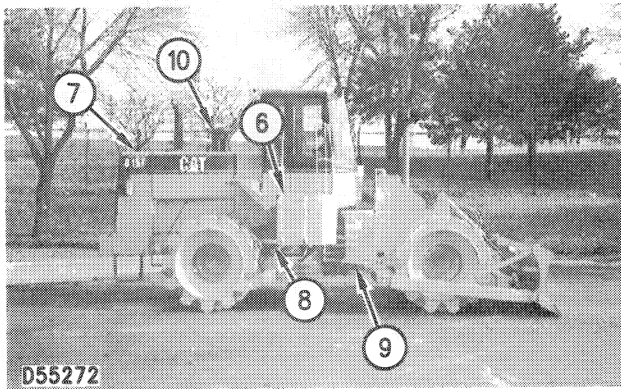

Hydraulic tank (6), radiator (7), transmission (8), steering frame lock link (9) and engine air cleaner (10).

| 814F Wheel Tractor      |                      |
|-------------------------|----------------------|
| Weight (approximate)    | 18611 kg (40,944 lb) |
| Length (with bulldozer) | 6844 mm (22 ft 5 in) |
| Width (with bulldozer)  | 3650 mm (12 ft)      |
| Height                  | 3368 mm (11 ft 0 in) |

| 815F Compactor          |                       |
|-------------------------|-----------------------|
| Weight (approximate)    | 20879 kg (45,933 lb)  |
| Length (with bulldozer) | 6820 mm (22 ft 4 in)  |
| Width (over drums)      | 3243 mm (10 ft 6 in)  |
| Width (with bulldozer)  | 3761 mm (12 ft 3 in)  |
| Height                  | 3343 mm (10 ft 10 in) |

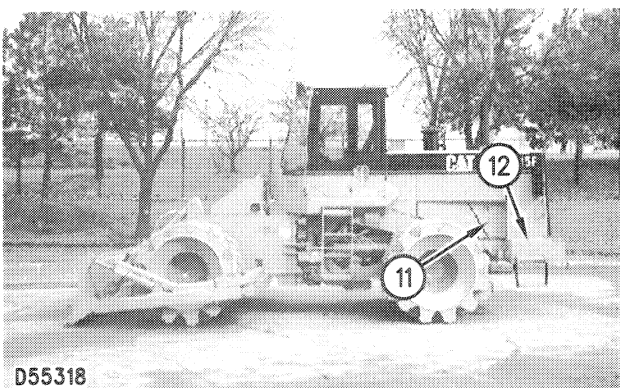

Key disconnect switch (11), and batteries (12).

| 816F Compactor          |                       |
|-------------------------|-----------------------|
| Weight (approximate)    | 22779 kg (50,114 lb)  |
| Length (with bulldozer) | 7791 mm (25 ft 6 in)  |
| Width (over drums)      | 3338 mm (10 ft 9 in)  |
| Width (with bulldozer)  | 3650 mm (11 ft 10 in) |
| Height                  | 3452 mm (11 ft 3 in)  |

*Top driving speed: Forward 23 MPH  
(Info. from Cat.) Reverse 26-27 MPH*

# Product Identification, Serial Number and CE Plate Locations

The Product Identification Number (PIN) will be used to identify a powered machine that is designed for an operator to ride.

Caterpillar products such as engines, transmissions, and major attachments, etc., not designed for an operator to ride are identified by Serial Numbers.

For quick reference, record the identification numbers in the spaces provided below the illustration.



Transmission Serial Number \_\_\_\_\_

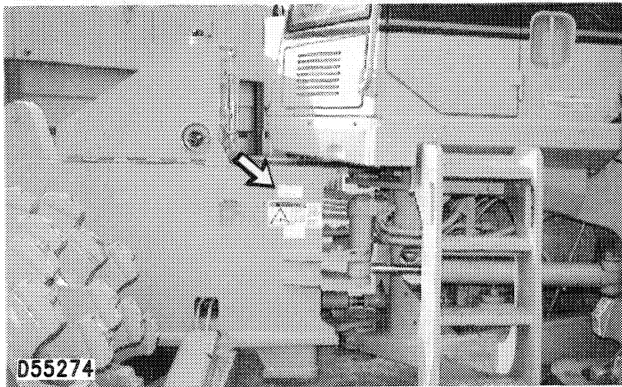

Machine PIN \_\_\_\_\_

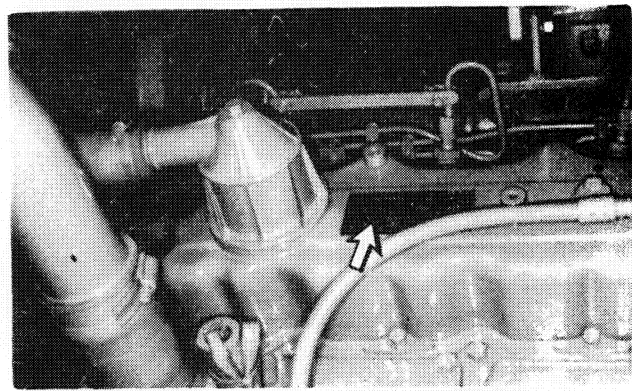

Engine Serial Number \_\_\_\_\_

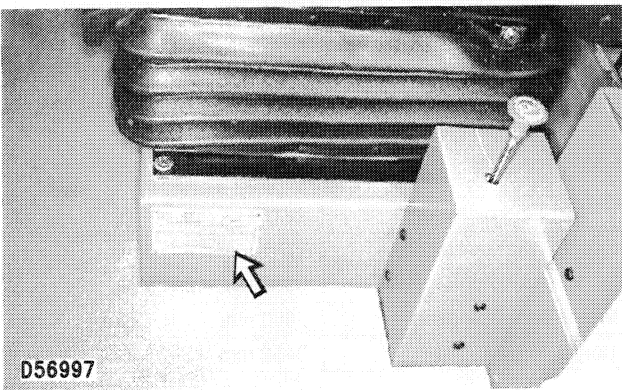

Service Information Number Plate (SIN) \_\_\_\_\_



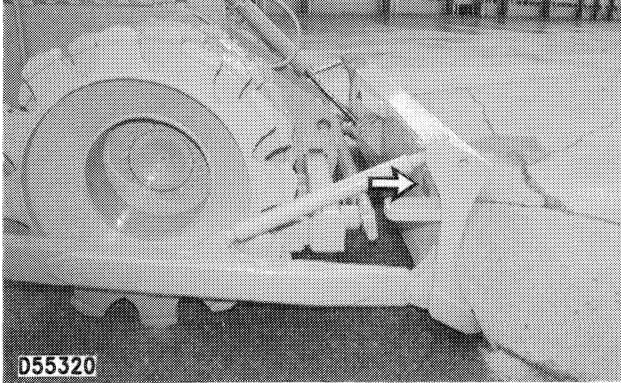

Bulldozer Serial Number \_\_\_\_\_

### EC Mark

Note: Plate on machines going into EC countries.



Plate is located on the left side of the frame.

PIN \_\_\_\_\_

Model \_\_\_\_\_

Power (kW) \_\_\_\_\_

Weight kg \_\_\_\_\_

## Monitoring Systems and Cab Features

### Battery Disconnect Switch

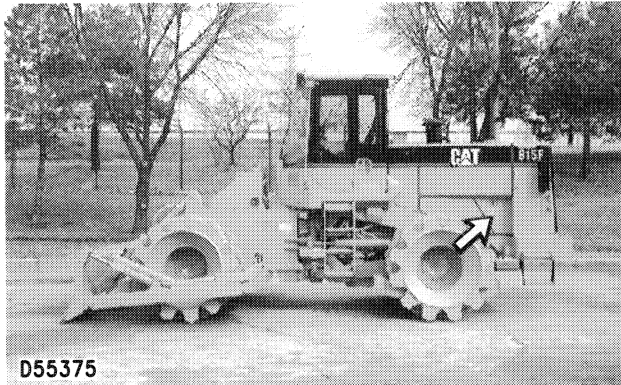

Open the access door on the left side of the machine. The battery disconnect switch is located in the engine compartment.

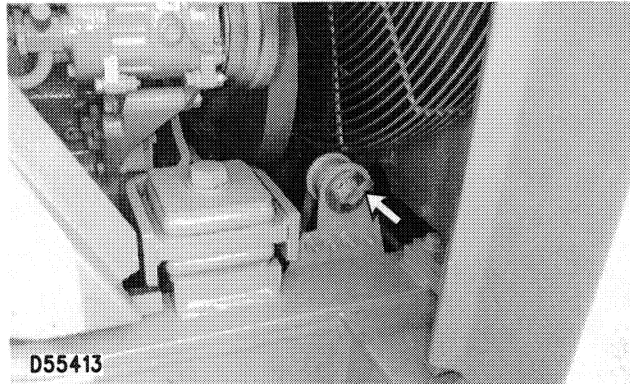

 **ON** – Insert the disconnect switch key, and turn it clockwise to activate the electrical system. The switch must be on before starting the engine.

 **OFF** – Turn the key counterclockwise to shut off the entire electrical system.

The disconnect switch serves a different function than the start switch. When turned off, the disconnect switch disables the entire electrical system. When only the start switch is turned off, the battery remains connected to the electrical system.

Turn the disconnect switch off and remove the key when servicing the electrical system or other components on the machine.

Turn the battery disconnect switch key to OFF and remove the key when leaving the machine for an extended period of a month or longer. This will prevent battery drain by short circuits or current draw made by some of the components, or by vandalism.

---

#### NOTICE

Never turn the disconnect key to OFF with the engine running. Electrical system damage could result.

---

### Engine Start Switch Key

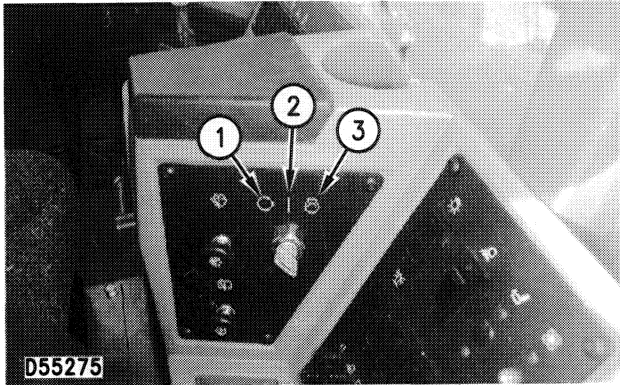

 OFF (1) – Insert and remove the engine start switch key from the OFF position only. No power to most electrical circuits in the cab. The cab lights, panel lights, tail lights and the fuel gauge light are operational even with the key start switch in the OFF position.

Turn the start switch key to OFF to stop the engine.

 ON (2) – Turn the start switch key clockwise to ON to activate all cab circuits.

 START (3) – Turn the start switch key clockwise to START to crank the engine. Release the key after engine starts and the key will return to ON.

NOTE: If the engine fails to start after turning the key to the start position, the key must be returned to the off position before another starting attempt is made.

### Ether Starting Aid

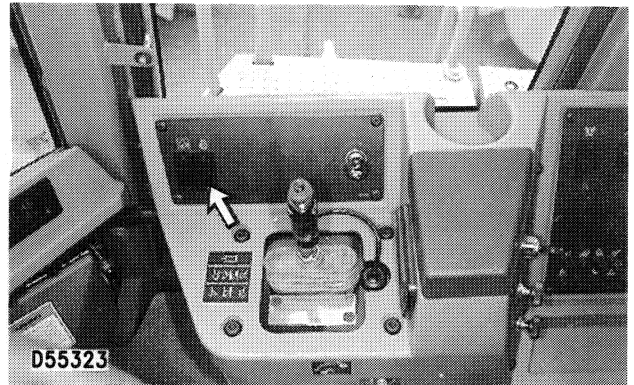

 Starting Aid – Push the top of switch in. When released, a premeasured amount of ether injects into the air intake.

---

#### NOTICE

Inject ether **ONLY** while cranking the engine. Use the ether sparingly. Excessive ether can cause piston and ring damage. Use when temperatures are below 0°C (+32°F) and for cold weather starting purposes. Refer to Engine Starting for further information.

---

### Caterpillar Monitoring System

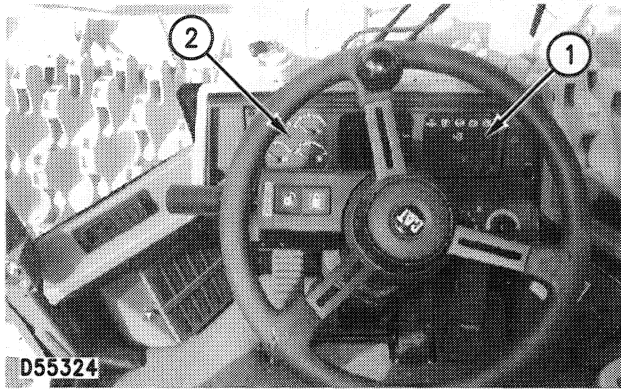

The Caterpillar Monitoring System is an electronic monitoring system that continuously watches machine systems. The monitoring system consists of a modular monitoring system that includes the monitoring system module (1) and a gauge module (2).

### Caterpillar Monitoring System Module

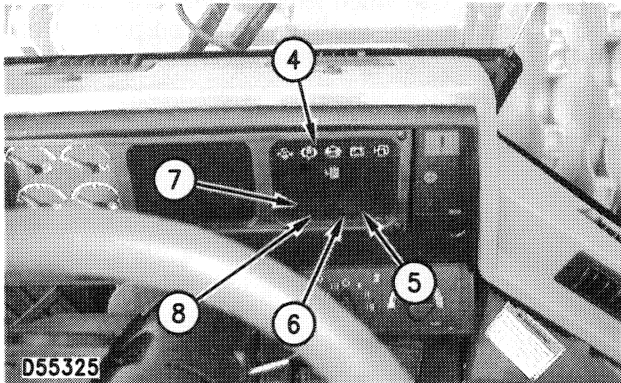

The Caterpillar Monitoring System module consists of several alert indicators (4) which show abnormal machine conditions.

The monitoring system module consists of a display window (5) that provides a six digit readout that shows machine operational hours (hourmeter), engine speed (tachometer), travel distance (odometer) or diagnostic codes.

The monitoring system module consists of six unit indicators (6), degree C, kPa, miles, km, rpm, and liter. The units of measurement for the data being displayed are switched on or off appropriately with the data being displayed.

The monitoring system module consists of an hour symbol indicator (7) which displays the machine operational hours.

The monitoring system module consists of a service code indicator (8) which displays a diagnostic code that has been detected and is active.

### Gauge Module

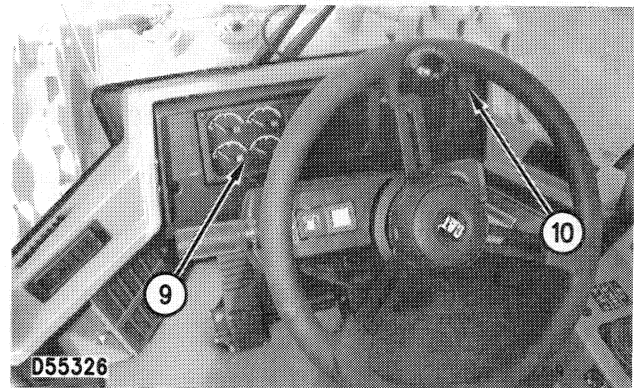

The four electronic gauges (9) consist of water temperature gauge, transmission oil temperature gauge, hydraulic oil temperature gauge and fuel level gauge.

In addition to the above indications, an external action lamp (10) and action alarm function to indicate the severity of machine warning categories.

### Caterpillar Monitoring System Functional Test ✓

The Caterpillar Monitoring System module performs an automatic self test each time the engine start switch key is turned from the OFF to the ON position.

The self test verifies that the monitoring system module and display modules are operating properly.

The internal circuits and the outputs (display, action lamp and action alarm) are automatically checked.

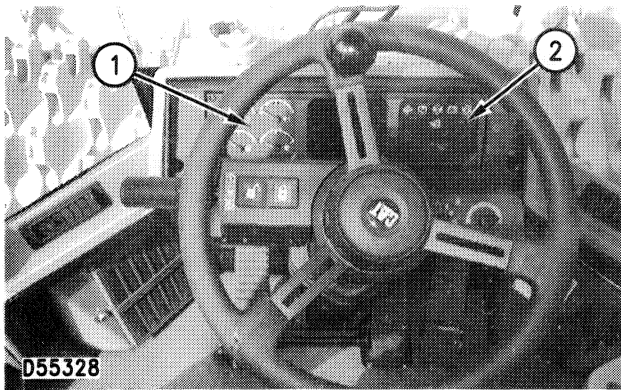

The operator must observe the outputs to determine whether or not the modules (1) and (2) and outputs are operating properly. The length of time for a self test is approximately three seconds.

During this self test, observe the following:

- All alert indicators flash.

The digital display window shows:

- All units indicators (Deg C, kPa, miles, km, rpm, liters).
- X10 indicator.
- Hourmeter symbol.
- 8.8.8.X.8.8. on the six digit readout.

Gauges ramp straight up, then to right, then to the left, and then to the final position.

- Gear readout shows \* \*.
- Speed readout shows 188, MPH and km/h.
- The action lamp is ON continuously.
- The action alarm sounds once.

The monitoring system module then goes into the Normal Mode of operation (or scrolls the modes if the service and clear or operator switch input is grounded).

### Caterpillar Monitoring System Warning Categories

The Caterpillar monitoring system provides three warning categories. The first category requires only operator awareness. The second warning category needs operator response. The third warning category requires immediate shutdown of the machine systems.

#### Warning Category 1

In this category, only the alert indicators will flash. It requires that the operator is aware that a machine system needs attention.

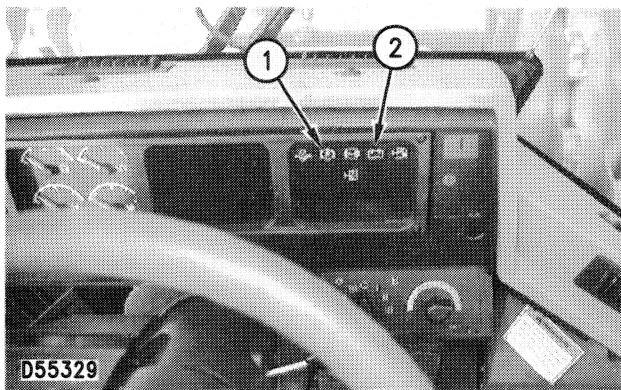

 **Parking Brake (1)** – Indicates parking brake is engaged and transmission is in NEUTRAL. The alert indicator should flash during start-up. It should go out when the parking brake is released.

 **Electrical System (2)** – Indicates a malfunction in the electrical system. If this alert indicator flashes, system voltage is either too high or too low for normal machine operation.

If the electrical loads are high (air conditioning and/or lighting) and the engine speed is low or near idle, increase engine speed to high idle. This will generate more output from the alternator. If the electrical system alert indicator turns off within about one minute, the electrical system is probably operating normally, but overloaded during periods of low engine speeds.

Modify operating cycle to keep from overloading the electrical system and discharging the batteries.

Low Idle must be correct. Adjust for high side of Low Idle specification with most often used electrical loads turned on. Reducing loads will also help, by using Medium cab fan speed instead of High.

If this procedure does not cause the alert indicator to turn off, pull to a convenient stop and investigate the cause (loose/broken alternator belt, defective batteries, etc.)

If engine speed is near operating speeds and if electrical loads are light, and the light remains on, pull to a convenient stop and investigate the cause (loose/broken belt, defective batteries or alternator).

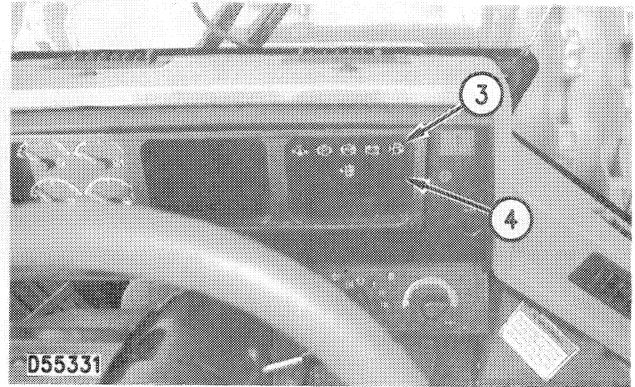

 **Fuel Level (3)** – The alert indicator will light up when the fuel level reaches 10% of tank capacity. To avoid being stranded without fuel, refuel as soon as possible within the hour.

 **Supplemental Steering (If Equipped) (4)** – The alert indicator will flash if there is a loss of supplemental steering oil flow.

The flashing indicator notifies the operator that if the primary steering system also failed at this time, there is no supplemental steering system for backup.

Immediately pull the machine to a convenient stop and shut the engine off.

NOTE: Machines are equipped with a ground driven supplemental steering pump. It is normal for the alert indicator to flash after 12 seconds when the machine is stopped.

### Warning Category 2

In this category, the alert indicator and the action light will flash. It requires a change in machine operation to reduce excessive temperature in one or more of the systems.

Do not operate the machine if the alert indicator and the action light continues to flash, after investigating the cause.

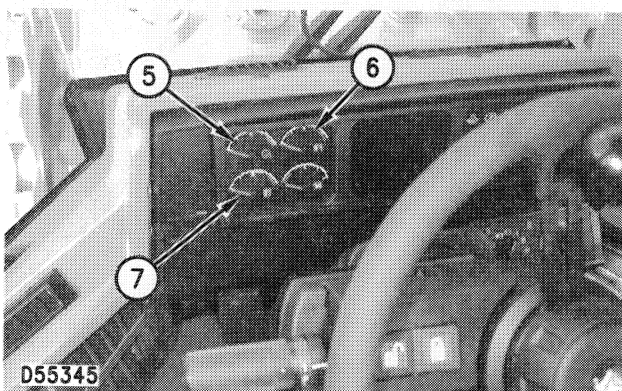

 **Coolant Temperature (5)** – Indicates excessive coolant temperature. If the needle of this gauge is in the red (abnormal) area, pull the machine to a convenient stop. Investigate the cause.

 **Transmission Oil Temperature (6)** – Indicates excessive converter/transmission oil temperature. If the needle of the gauge is in the red (abnormal) area, reduce load on the machine. If the needle of the gauge is in the red (abnormal) area and the action light continues to flash after approximately five minutes, pull to a convenient stop. Investigate the cause.

 **Hydraulic Oil Temperature (7)** – Indicates excessive hydraulic oil temperature. If the needle of the gauge is in the red (abnormal) area, reduce the load on the system. If the needle of the gauge remains in the red (abnormal) area, pull the machine to a convenient stop. Investigate the cause.

### Warning Category 3

In this category, the alert indicator and the action light will flash and the action alarm will sound. It requires immediate shutdown of operation to prevent severe damage to the system and/or the machine.

Do not operate the machine until the cause has been corrected.

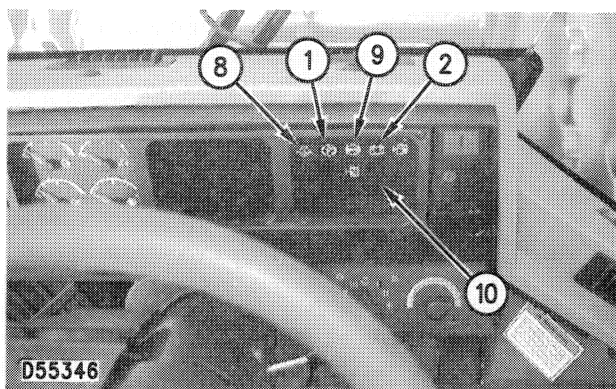

 **Engine Oil Pressure (8)** – Indicates low oil pressure. If this alert indicator flashes, stop the machine immediately. Stop the engine and investigate the cause.

 **Parking Brake (1)** – Indicates parking brake is engaged. If the alert indicator flashes during operation, stop the machine immediately. Stop the engine. Investigate the cause.

If the parking brake and the transmission are engaged during engine start-up, the alert indicator will flash, the action light will flash and the action alarm will sound. Move the transmission lever to NEUTRAL to stop the action alarm.

 **Brake Oil Pressure (9)** – Indicates low oil pressure to the brakes. If this alert indicator flashes, stop the machine immediately. Engage the parking brake and stop the engine. Investigate the cause.

 **Electrical System (2)** – Indicates a serious malfunction in the electrical system. If this alert indicator flashes during operation, stop the machine immediately. Stop the engine. Investigate the cause.



**Primary Steering (10)** – Indicates the primary steering has failed and supplemental steering (if equipped) is being used. If this alert indicator flashes during operation, stop the machine immediately. Stop the engine and investigate the cause.

Do not operate the machine until the cause has been corrected.

Supplemental steering works only while the machine is moving. When the machine operates under supplemental steering, no directional changes can be made.

**Gauges**

The gauge performs a self test by cycling the gauge needles to the straight up position, then to the far right position (maximum), and then to the far left position (minimum). At the end of the self test the gauge will display the correct gauge information.

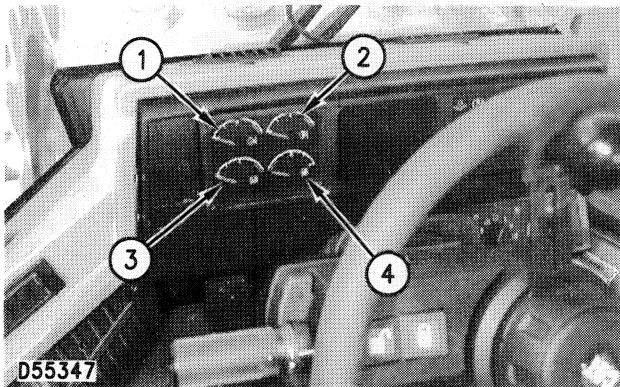

**Engine Coolant Temperature (1)** – Indicates the temperature of the engine coolant. The red area is excessive engine coolant temperature.



**Torque Converter Oil Temperature (2)** – Indicates the temperature of the torque converter oil. The red area is excessive oil temperature.



**Hydraulic Oil Temperature (3)** – Indicates the temperature of the hydraulic oil. The red area is excessive oil temperature.



**Fuel Level (4)** – Shows the amount of fuel in the fuel tank.

**Digital Display Window**

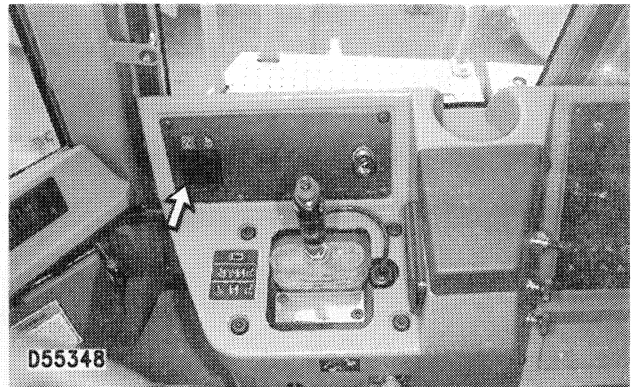

Press the switch located on the right side console to scroll through the units of measurement for the data being displayed.

The display window provides a six digit readout which shows: Operational hours (service hours), engine speed (tachometer), machine distance (odometer) or diagnostic codes.

Any of the gauges may also be monitored digitally if selected by the operator to appear in the readout.

**Service Hour Meter**

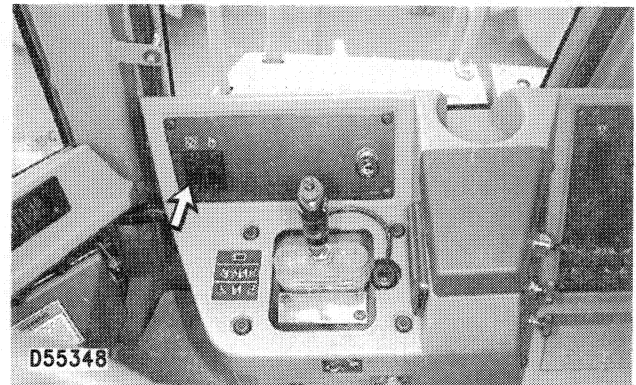

Press the switch located on the right side console to scroll through the units of measurement until the service hours are displayed.





 **Service Hour Meter** – Indicates the total operating hours of the engine. It should be used to determine service hour maintenance intervals. The total operating hours of the engine will be displayed in the digital display window located in the instrument panel.

#### Service Code

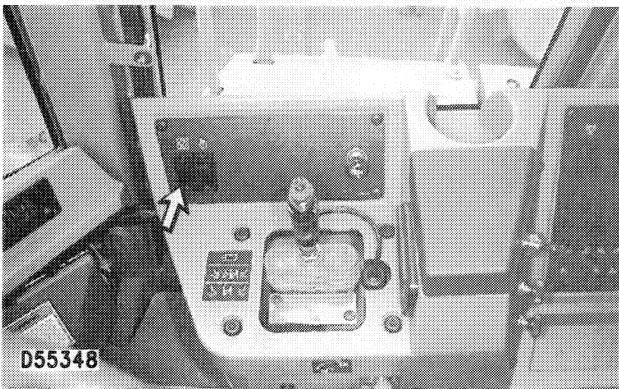

Press the switch located on the right side console to scroll through the units of measurement to display the service code.

The service code indicator displays that a diagnostic code has been detected and is active.

Diagnostic information is available in the service mode for service personnel.

Refer to the SENR6717 for Caterpillar Monitoring System Service Manual Module.

#### Light Switches

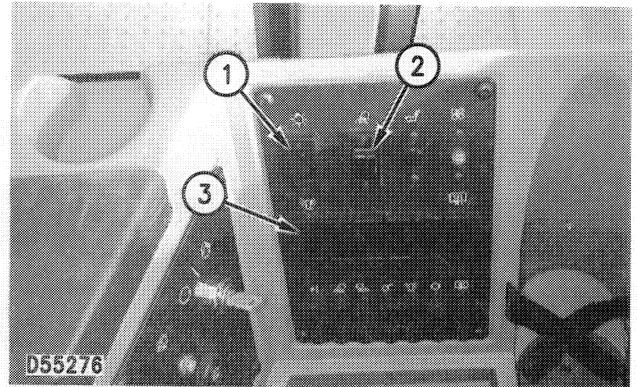

 **Panel, Tail and Running Lights (1)** – Move the switch to the top position to turn on the panel lights, tail and running lights. Move the switch to the middle position to turn on the instrument panel and tail lights. The bottom position turns the lights off.

 **Flood Lights (2)** – Move the switch to the top position to turn on rear flood lights. Move the switch to the bottom position to turn the lights off.

 **Rotating Beacon (3)** – Move the switch to the top position to turn on rotating beacon. Move the switch to the bottom position to turn off the rotating beacon.



 **Interior Dome Light** – Move the switch back to turn the light on.

### Windshield Wiper/Washer

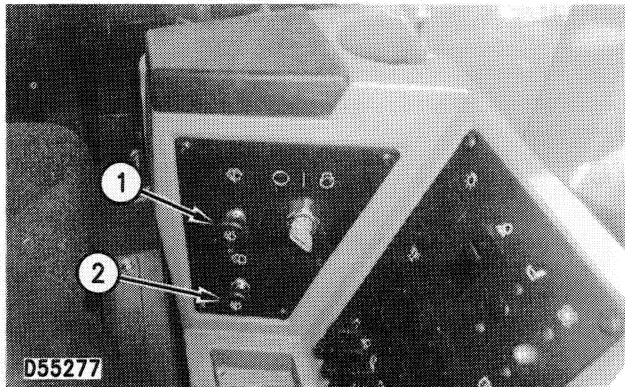

Front Windshield Wiper and Washer (1)



Rear Windshield Wiper and Washer (2)

Turn the knob clockwise to turn on the windshield wiper. Push the knob to activate the windshield washer. Spring force will return the knob when released.

### Horn

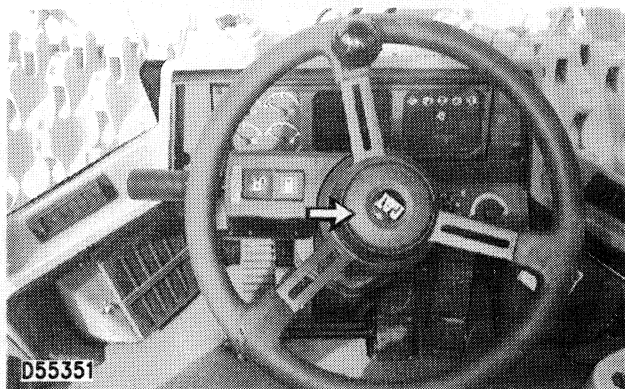

Horn – Push the button in the center of the steering wheel to sound the horn. Use the horn to alert or to signal personnel.

### Backup Alarm



Backup Alarm – The alarm will sound when the transmission control lever is in the reverse position. It is used to alert people behind the machine that it is backing up.

The backup alarm is located on the rear of the machine.

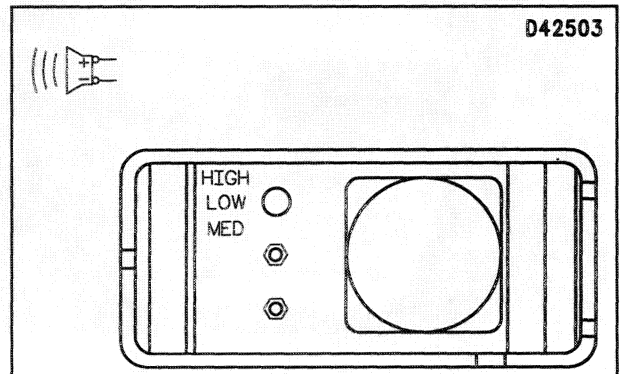



A three position switch (high, low and medium) at the rear of the backup alarm regulates its volume.

The alarm is set at the highest sound level when shipped from the factory. The setting should remain on high, unless the job site requires a lower level.

### Heating and Air Conditioning Controls (If Equipped)

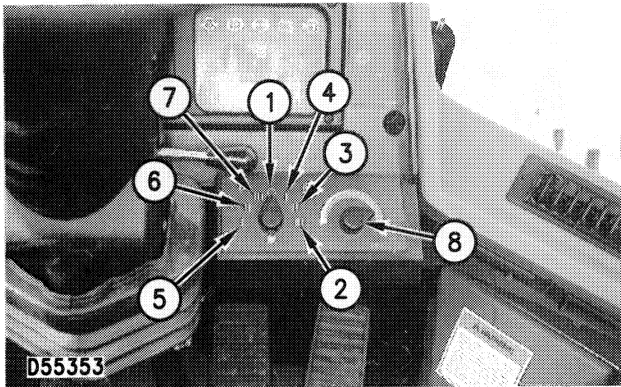
#### Fan Control





 **Heat and Air Conditioning Fan Speed Switch** – This switch controls the heating and air conditioning three speed blower fan motor.

**Off (1)** – Move the switch to the top position to stop the blower fan.

Move the switch to the right to operate the heating system.

 **High – (2)** – Move the switch to this symbol for highest fan speed.

 **Medium – (3)** – Move the switch to this symbol for a medium fan speed.

 **Low – (4)** – Move the switch to this symbol for lowest fan speed.

Move the switch to the left to operate the air conditioning system.

 **Low – (5)** – Move the switch to this symbol for lowest fan speed.

 **Medium – (6)** – Move the switch to this symbol for a medium fan speed.

 **High – (7)** – Move the switch to this symbol for highest fan speed.

#### Temperature Control – Heater

 **Temperature Variable** – Turn the knob (8) anywhere between OFF (left) and MAXIMUM (right) heat.



#### Temperature Control – Air Conditioning

 **Temperature Variable** – Turn the knob (8) anywhere between OFF (left) and MAXIMUM (right) cool.



#### Heating and Air Conditioning System Operation

The heating and air conditioning system can perform four functions:

 **Heating** – Turn the blower fan switch to LOW, MEDIUM or HIGH speed. Adjust the temperature variable control for the desired temperature.

 **Cooling** – Turn the blower fan switch to LOW, MEDIUM or HIGH speed. Adjust the temperature variable control for the desired temperature.

 **Pressurizing** – Pressure inside of the cab will help keep dust out, when heating or cooling is not desired.

Turn the temperature variable controls to OFF. Turn heating fan to either LOW, MEDIUM or HIGH speed, depending on the volume of air needed to keep out dust.

 **Defogging** – Turn the air conditioning fan to either LOW, MEDIUM or HIGH speed, depending on the volume of air needed to remove moisture from the air in the cab. This will prevent moisture from forming on the windshield and windows.

Turn on the blower fan. Adjust temperature controls until moisture level is lowered. Adjust the temperature controls until it is comfortable and windshield and side windows are free of moisture.

### Seat

NOTE: Adjust the seat at the beginning of each shift or when changing operators.

Adjust the seat to allow full travel of the pedals when the operator is seated against the seat back.

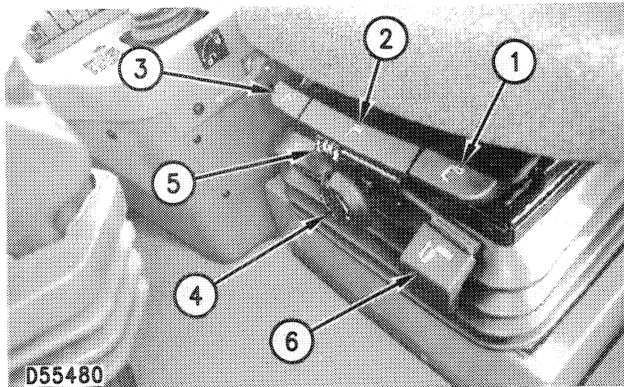

Pull up the back cushion angle lever (1). Hold the lever up, adjust the seat cushion to the desired angle. Release the lever to lock the seat cushion.

Pull up the fore-aft lever (2). Hold the lever up, slide the seat forward or back to the desired position. Release the lever to lock the seat into position.

Pull up the seat cushion angle lever (3) and raise the front of the seat cushion to the desired angle. Pull up the lever and push down the front of the seat cushion to lower into the desired position. Release the lever to lock the seat cushion in one of three positions.

Turn the knob (4) clockwise to increase or counterclockwise to decrease the stiffness of the suspension. Use the indicator (5) for approximate weight setting.

Pull Up the seat height level lever (6) to release the seat height lock. Move the seat to the desired height. Release the lever to lock the seat into position.

NOTE: Contour Series Seat Installation and Repair information is available in Service Manual module SENR6615.

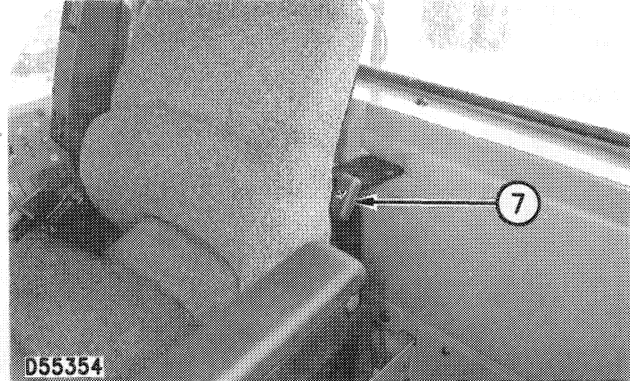

Push lower back support lever (7) (If Equipped) to the rear and down to increase support to the lower back. Pull the lever forward and up to decrease support to the lower back. Release the lever to lock the lower back support.

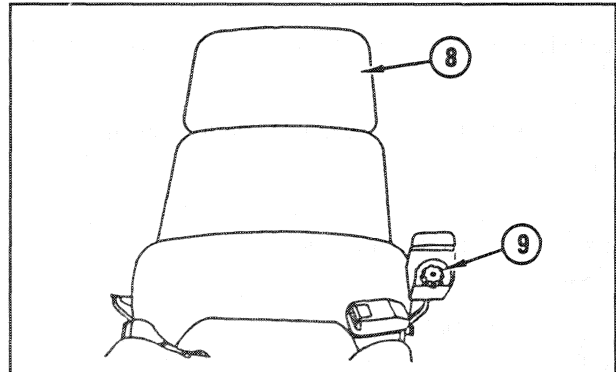

Pull up to remove backrest extension (8).

Rotate the knob (9) to adjust the angle of the armrest when in the operating position.

## Seat Belt

Always check the condition of the seat belt and mounting hardware before operating the machine.

Replace the seat belt at least once every three years, regardless of appearance. A date label, to determine the age of the belt, is attached to each belt.

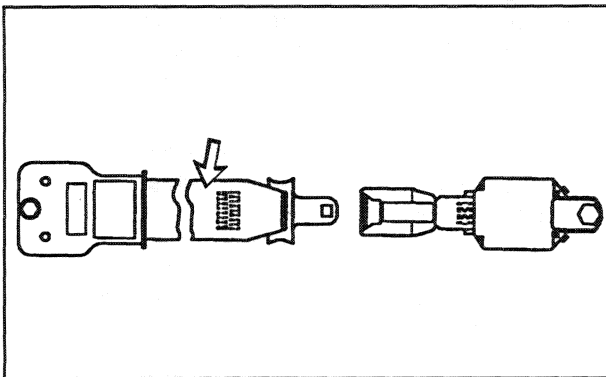

Inspect for worn or frayed webbing.

Check for worn or damaged buckle. Replace the belt and buckle if they are worn or damaged.

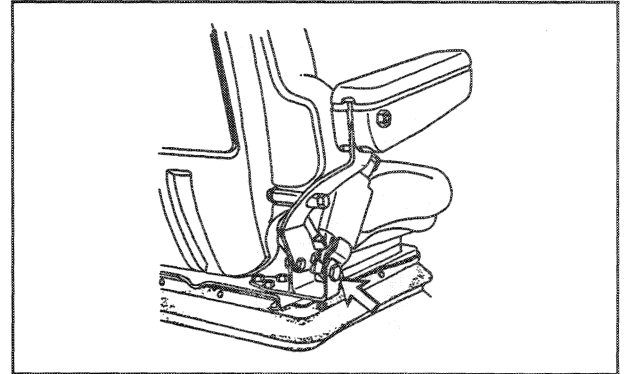

Inspect the belt mounting hardware. Replace any damaged or worn hardware. Keep the mounting bolts tight.

## Seat Belt Adjustment

The seat belt is equipped with an automatic locking retractor. This retractor will lock if the belt is pulled or jerked after belt is pulled out of the retractor.

The buckle end of the seat belt is equipped with a comfort ride sleeve. This sleeve will allow the operator limited movement with the seat belt fastened.

### To Fasten the Seat Belt

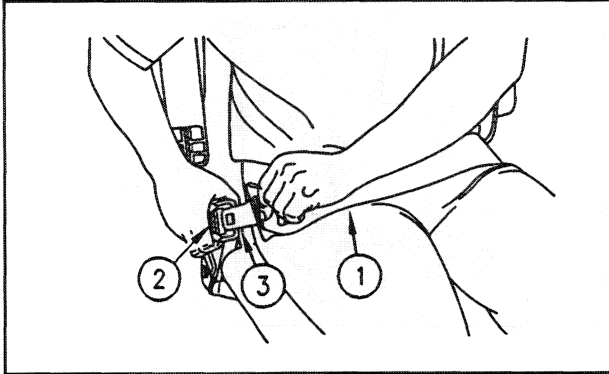

Pull the seat belt (1) over to the belt catch (2) in a continuous motion.

Insert the buckle (3) into the seat belt catch (2). Check to be sure seat belt is placed low across lap/mid-section of the operator.

**NOTE:** Do not pull the seat belt catch (2) out or the comfort ride feature will not function.

The retractor will adjust the belt length and lock in place. The comfort ride sleeve will allow the operator limited movement.

### To Release the Seat Belt

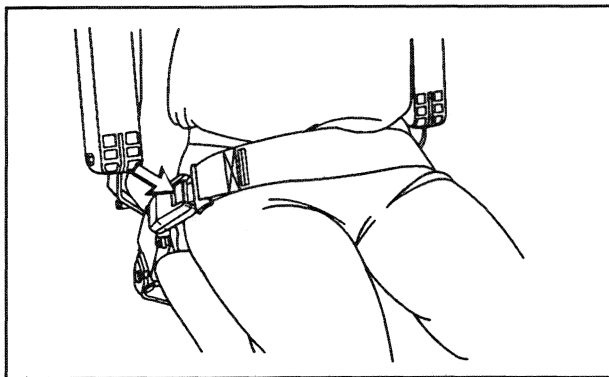

Push the release button on the buckle to release the seat belt. The seat belt will automatically retract into the retractor.

### Seat Belt Extension



**When using retractable seat belts, do not use seat belt extensions, or personal injury or death can result.**

**The retractor system may or may not lockup depending on the length of the extension and the size of the person. If the retractor does not lockup, the seat belt will not retain the person.**

Caterpillar's recommendation for extending a retractable seat belt is to replace it with a nonretractable belt.

Longer seat belts and seat belt extensions are available, when the seat belt is not of sufficient length for the operator.

Contact any Caterpillar dealer for longer seat belt and seat belt extension information.

### Mirror

#### Mirror

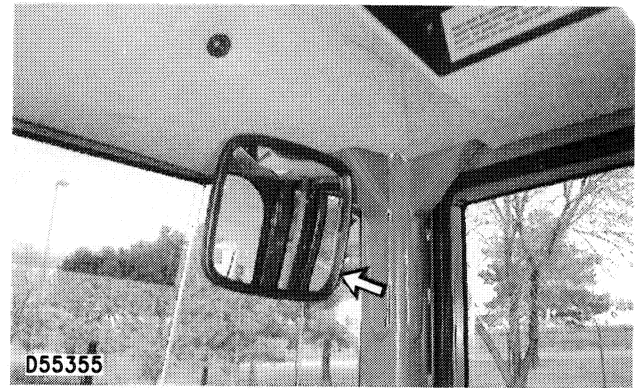

Adjust the two cab rearview mirrors, for best operator vision before operating the machine or when operators change.

### Lighter

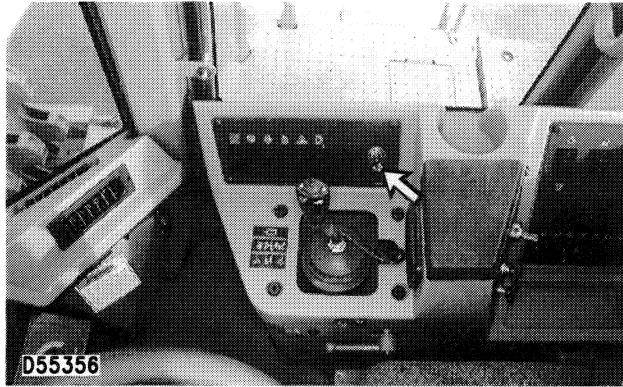

**Lighter** – Push the lighter in and release. The lighter will move out slightly when ready for use.

### Window Cleaning

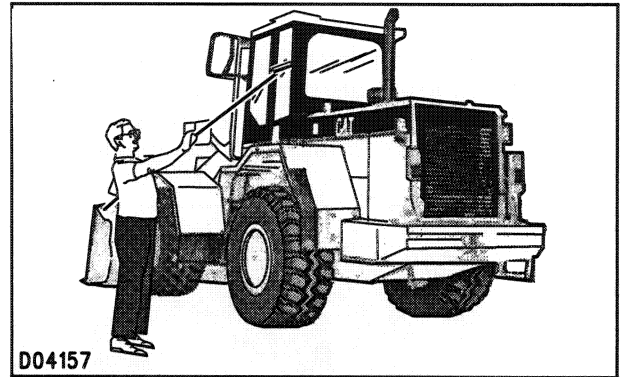

Use commercially available window cleaning solutions to clean the windows. Clean the outside windows from the ground, unless handholds are available.

### Alternate Exit



The cab window on the right side serves as an alternate exit. It can be opened from the inside only. Release the latch and open the window.

This will eliminate cab pressurization.

To release the right cab window from the fully open position, push the release button.

## Machine Controls

### Parking Brake

#### NOTICE

Do not engage the parking brake while the machine is moving unless the primary service brake fails. The use of the parking brake as a service brake in regular operation will cause severe damage to the brake system.

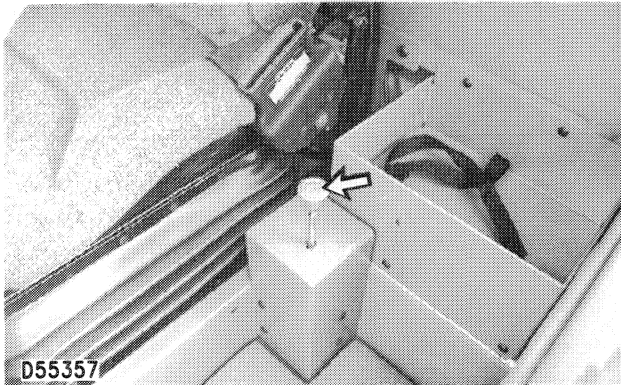

 **Parking Brake** – The parking brake knob is located on the left side of the operator seat on the floor. The parking brake is to be used after the machine has been stopped.

 **Parking Brake Engaged** – Pull the knob out to engage the parking brake.

 **Parking Brake Disengaged** – Push the knob in to release the parking brake.

 **Secondary Brake** – The secondary brake uses the same knob as the parking brake. The secondary brake is to be used if the service brakes fail to stop the machine.

### Brake Pedals

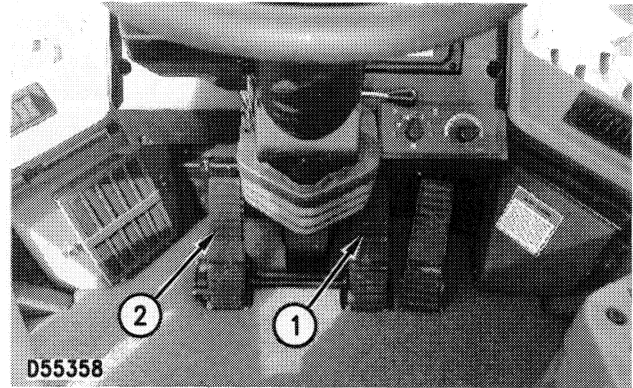

 **Left Brake Pedal** – Apply the left brake pedal (2) when positioning and raising the dozer blade at the same time.

 Release the pedal to re-engage the transmission and to release the brake.

 **Right Brake Pedal** – Depress the right brake pedal (1) for normal machine braking.

 Release the pedal to release the brake.



### Accelerator Pedal

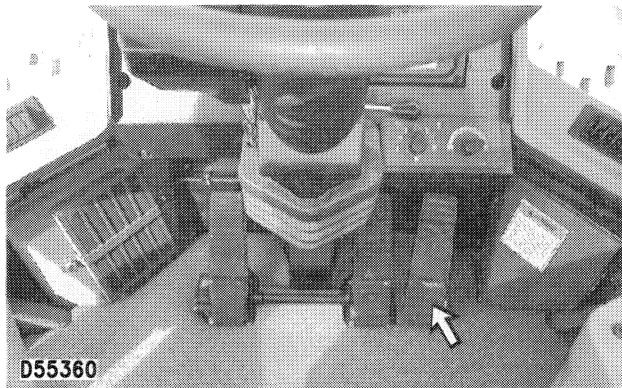

**Accelerator Pedal** – The accelerator pedal is located on the floor of the operator's station, at the right.



Push down the pedal to increase travel speed.



Release the pedal to decrease travel speed.

### Transmission Neutral Lock

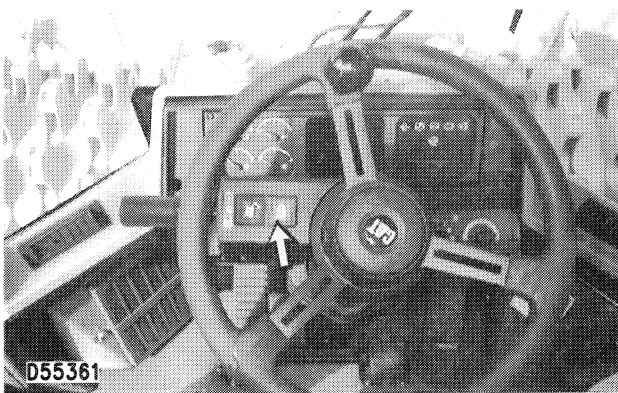

**Locked** – Move the transmission control lever into the NEUTRAL position. Press the right side of the switch to lock the transmission control into the NEUTRAL position.



**Unlocked** – Press the left side of the switch to unlock the transmission control.

### Transmission Direction and Speed Control

#### Direction Selector

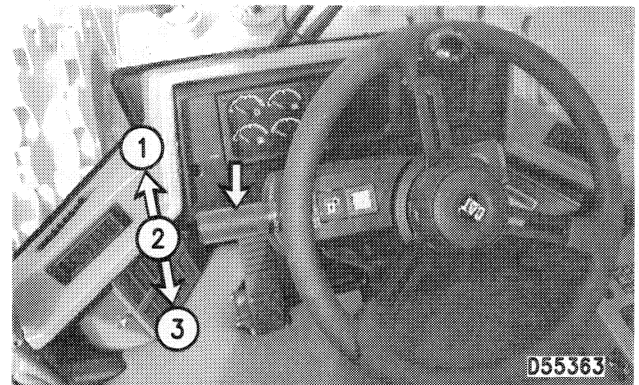

**FORWARD (1)** – Move the transmission lever up. The machine will move forward.



**NEUTRAL (2)** – The machine should not move when transmission lever is in neutral.



**REVERSE (3)** – Move the transmission lever down. The machine will move in reverse.

#### Speed Selector

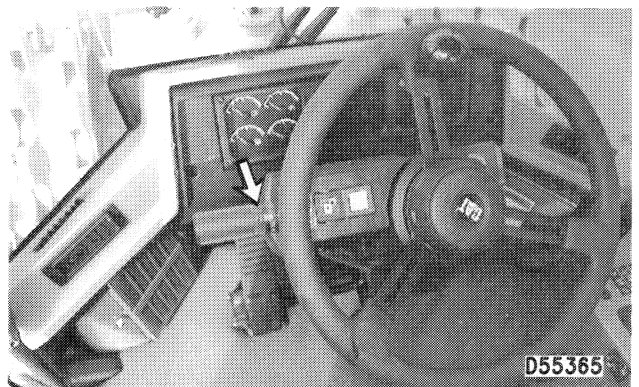

Rotate the transmission lever to the desired gear speed:

- 1 – First Speed
- 2 – Second Speed
- 3 – Third Speed
- 4 – Fourth Speed

### Transmission Up/Down Shift Control

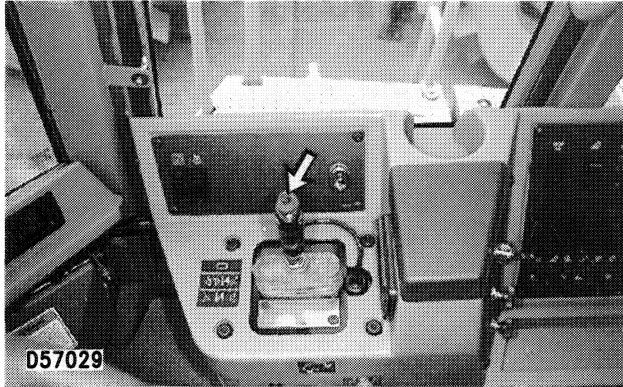

When the transmission speed selector lever is in first or second gear only, the transmission can be up shifted or down shifted between first and second by depressing the button on top of the attachment control lever.

### Steering Controls

#### Directional Steering

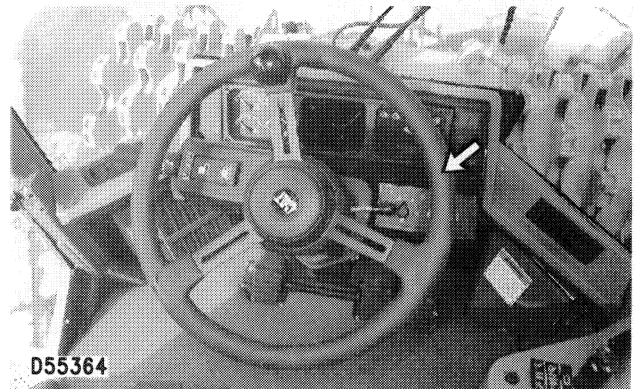

The directional steering, of the machine, is controlled by the steering wheel. The direction the steering wheel is turned is the direction that the machine will turn.

The steering frame lock must be removed to steer the machine. See "Before Starting the Engine" for information.



**Left Turn** – Move the steering wheel in a counterclockwise direction to steer the machine, to the left. The farther the steering wheel is turned in a counterclockwise direction the sharper the left turn.



**Right Turn** – Move the steering wheel in a clockwise direction to steer the machine, to the right. The farther the steering wheel is turned in a clockwise direction the sharper the right turn.

### Steering Column Tilting

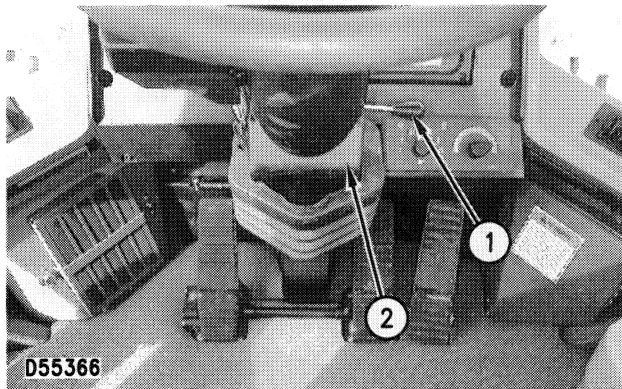



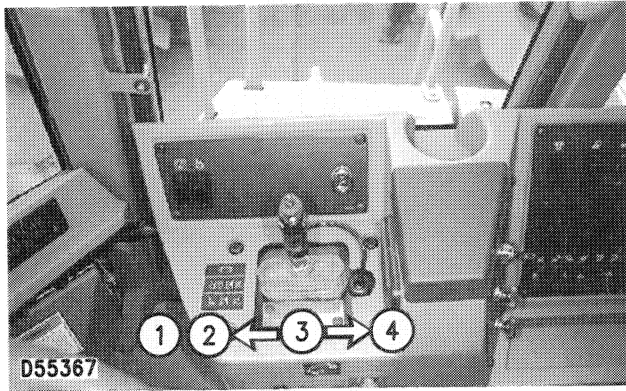

To adjust the steering column, pull the steering column tilt lever (1) up and move the steering column (2) to the desired position. Release the steering column tilt lever (1) and the steering column will remain in the desired position.

## Attachment Controls



### Bulldozer Blade Control Lever

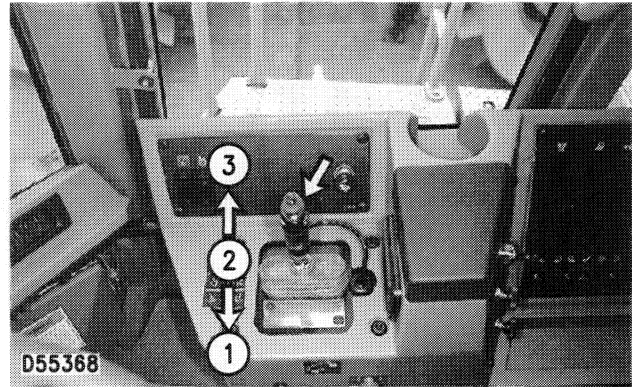

-  **Float (1)** – Push the lever forward into detent, the blade will lower to the ground and move up and down, following ground contour. The lever will remain in detent until pulled out. The lever will then return to HOLD when released.
-  **Lower (2)** – Push the lever forward to lower the blade. The lever will return to HOLD when released. The blade will remain in the position it is in.
-  **Hold (3)** – The blade will remain in the position it is in.
-  **Raise (4)** – Pull the lever back to raise the blade. The lever will return to HOLD when released. The blade will remain in the position it is in.

### Bulldozer Blade Tilt Lever



-  **Tilt left (1)** – Move the lever to the left (towards the operator). The blade will tilt left. The lever will return to HOLD when released. The blade will remain in the position it is in.
-  **Hold (2)** – The blade will remain in the position it is in.
-  **Tilt Right (3)** – Move the lever to the right (away from the operator). The blade will tilt right. The lever will return to HOLD when released. The blade will remain in the position it is in.

### Bulldozer Blade Tip Lever

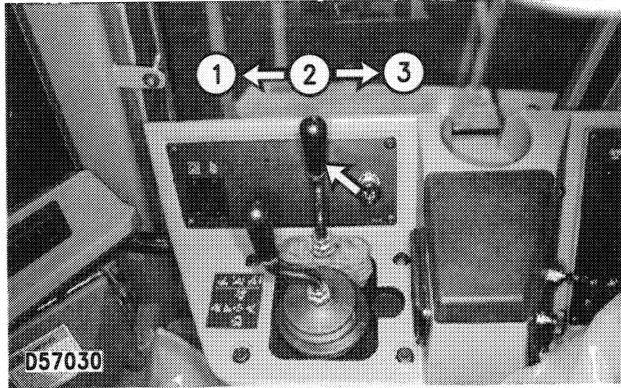

**Tip Forward (1)** – Push the lever forward and the top of the blade will tip forward. The lever will return to HOLD when released. The blade will remain in the position it is in.



**Hold (2)** – The blade will remain in the position it is in.



**Tip Back (3)** – Pull the lever back and the top of the blade will tip back. The lever will return to HOLD when released. The blade will remain in the position it is in.

### Attachment Control Lever Lock

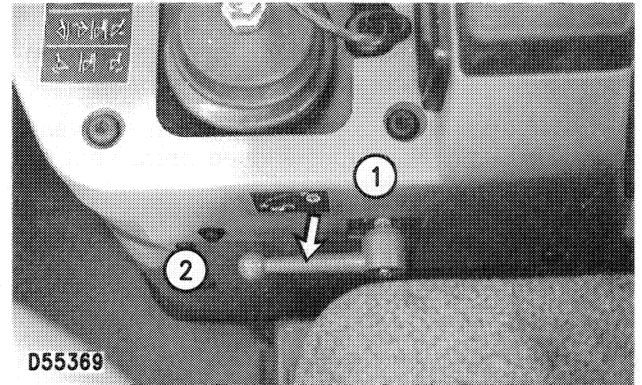

**LOCKED (1)** – Pull the knob toward the operator to lock the attachment control lever lock and lock the attachment control levers.



**UNLOCKED (2)** – Push the knob away from the operator to unlock the attachment control lever lock and release the attachment control levers.

## Before Starting the Engine

### WARNING

Diesel engine exhaust contains products of combustion which may be harmful to your health.

Always start and operate the engine in a well-ventilated area and, if in an enclosed area, vent the exhaust to the outside.

### Mounting The Machine

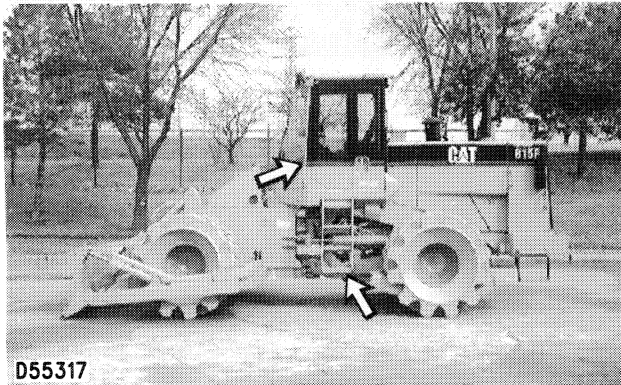

- Mount the machine only where steps and/or handholds are provided.
- Inspect, and when necessary, clean and have repairs made to steps and handholds before mounting.

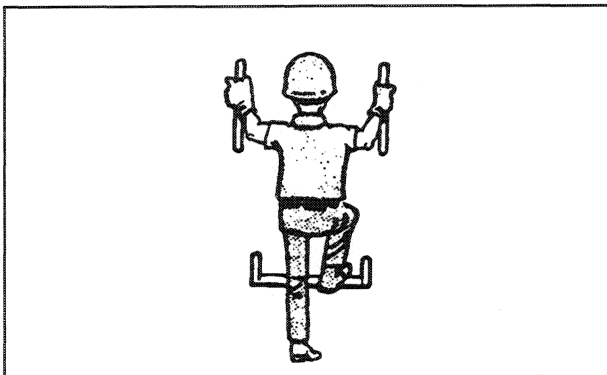

- Face the machine when mounting.
- Maintain a three-point contact (two feet and one hand or one foot and two hands contact) with the steps and handholds.

### Machine Walk-Around Inspection

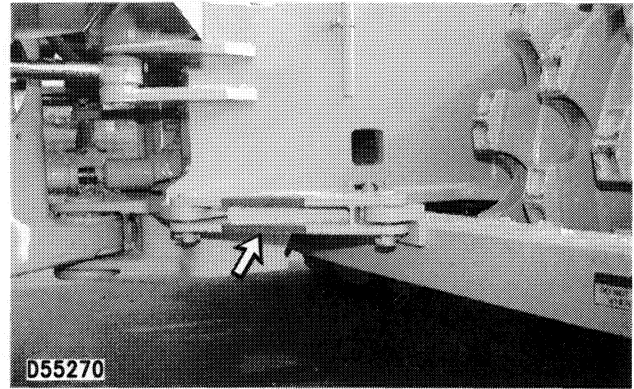

Remove steering frame lock link and store in unlocked position as shown. The steering frame lock link must be removed to steer the machine.

For maximum service life of the machine, make a thorough walk-around inspection before mounting the machine to start the engine.

Look around and under the machine for loose bolts, trash build-up, oil or coolant leaks, broken or worn parts. Inspect the condition of the dozer blade and the hydraulic components.

Check all of the oil, coolant and fuel levels.

Refer to the Every 10 Service Hours or Daily in the Maintenance Section for more detailed information.

Refer to Walk-Around Inspection in the Maintenance Section for detailed walk-around inspection information.

### Seat and Seat Belt Checks

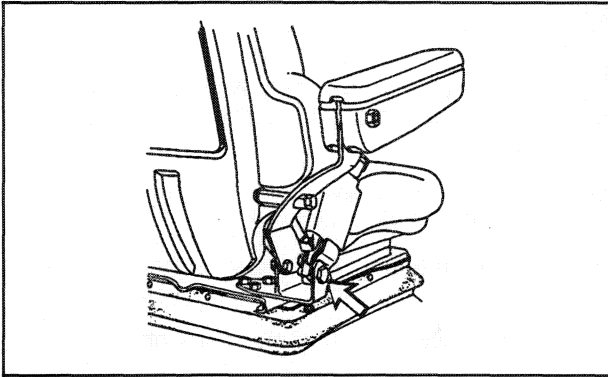

NOTE: Adjust the seat at the beginning of each shift or when changing operators.

Adjust the seat to allow full travel of the pedals when the operator is seated against the seat back.

Inspect the belt mounting hardware. Replace any damaged or worn hardware. Keep the mounting bolts tight.

Fasten the seat belt before starting the engine.

## Engine Starting

### Engine Starting Above 0°C (+32°F)



1. Move the transmission directional control lever into NEUTRAL.
2. Unlock the steering column. Move the steering column to the desired position and lock.

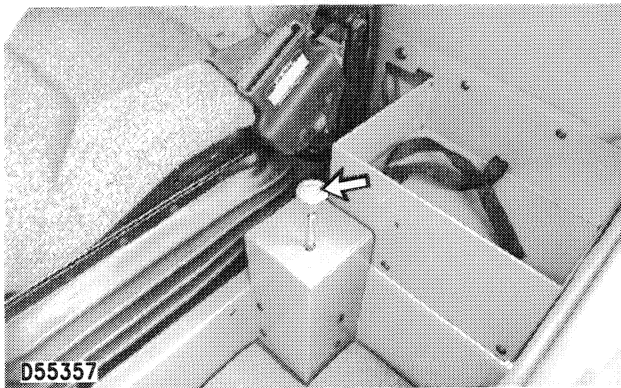

3. Engage the parking brake.
4. Move the control levers to the HOLD position.
5. Turn the start switch key to start the engine. Release the key when engine starts.

---

#### NOTICE

Do not crank the engine for more than 30 seconds. Allow the starter to cool for two minutes before cranking again.

Turbocharger (if equipped) damage can result, if the engine rpm is not kept low until the engine oil light-/gauge verifies the oil pressure is sufficient.

---

### Engine Starting Below 0°C (+32°F) (If Equipped with Ether Starting Aid)

---

#### NOTICE

Inject starting aid (ether), only while cranking the engine, or after initial start-up, until the engine is running smoothly.

Use sparingly, excessive ether without cranking can cause piston and ring damage.

Wait approximately two seconds before injecting again.

Use ether for cold starting purposes only.

After every 30 seconds of engine cranking, allow two minutes for starting motor to cool before cranking again.

Turbocharger (if equipped) damage can result, if the engine rpm is not kept low until the engine oil light-/gauge verifies the oil pressure is sufficient.

---

1. Follow steps 1 through 4 in Engine Starting Above 0°C (+32°F). Then proceed with the following steps.
2. Turn the start switch key to start the engine.

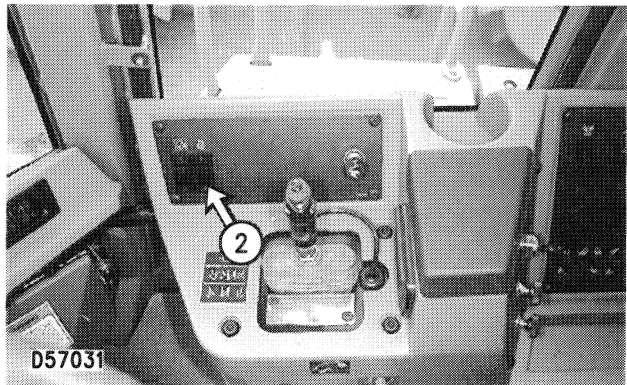

3. Push the starting aid (ether) switch (2) and release.
4. Operate the start aid switch every two seconds while cranking the engine. Continue use until the engine starts and is running smoothly.
5. Release the start switch key when the engine starts.



For starting below  $-18^{\circ}\text{C}$  ( $0^{\circ}\text{F}$ ), use of optional cold weather starting aids is recommended. A coolant heater, fuel heater, jacket water heater or extra battery capacity may be required.

At temperatures below  $-23^{\circ}\text{C}$  ( $-10^{\circ}\text{F}$ ), consult your Caterpillar dealer, or refer to the Operation & Maintenance Manual for Cold Weather Recommendations, SEBU5898, available from your Caterpillar dealer.

### Engine Starting with Jump Start Cables

#### **WARNING**

**Batteries give off flammable fumes that can explode resulting in personal injury.**

**Prevent sparks near the batteries. They could cause vapors to explode. Do not allow the jump start cable ends to contact each other or the machine.**

**Do not smoke when checking battery electrolyte levels.**

**Electrolyte is an acid and can cause personal injury if it contacts skin or eyes.**

**Always wear eye protection when starting a machine with jump start cables.**

**Improper jump start procedures can cause an explosion resulting in personal injury.**

**Always connect the battery positive (+) to battery positive (+) and the battery negative (-) to battery negative (-).**

**Jump start only with an energy source with the same voltage as the stalled machine.**

**Turn off all lights and accessories on the stalled machine. Otherwise, they will operate when the energy source is connected.**

---

#### NOTICE

When starting from another machine, make sure the machines do not touch. This could prevent damage to engine bearings and electrical circuits.

Turn on (close) the disconnect switch prior to the boost connection to prevent damage to electrical components on the stalled machine.

Severely discharged maintenance free batteries will not fully recharge from the alternator alone after jump starting. The batteries must be charged to the proper voltage with a battery charger. Many batteries thought to be unusable, are still rechargeable.

This machine has a 24 volt starting system. Use only equal voltage for jump starting. Use of a higher voltage will damage the electrical system.

Refer to Special Instruction, Battery Test Procedure, SEHS7633, available from your Caterpillar dealer, for complete testing and charging information.

---

#### Use of Jump Start Cables

When auxiliary start receptacles are not available, use the following procedure.

1. Make initial determination as to failure of machine to crank. Refer to Special Instruction SEHS7768 on use of 6V2150 Starting/Charging Analyzer Group. Procedure applies even if machine does not have diagnostic connector.
2. Move the transmission control into NEUTRAL on the stalled machine. Engage the parking brake. Lower the attachment to the ground. Move all controls to HOLD.
3. On stalled machine, turn the start switch key to OFF. Turn off all accessories.
4. On stalled machine, turn on (close) the disconnect switch (if equipped).
5. Move electrical source machine near enough to stalled machine for the jump start cables to reach. But, do not allow machines to touch.
6. Stop the engine on the electrical source machine. Or, if using an auxiliary power source, turn off the charging system.
7. Make sure battery caps are all in place and tight on both machines and that batteries in the stalled machine are not frozen or low on electrolyte.



**8.** Connect one end of positive (+) jump start cable (red) to positive (+) cable terminal of discharged battery, or battery set on stalled machine.

NOTE: Batteries in series may be located in separate compartments. Use terminal that is connected to starter solenoid. This battery, or battery set, is normally on the same side of the machine as the starter.

Do not allow positive (+) cable clamps to touch any metal other than battery terminals.

**9.** Connect the other end of this positive (+) jump start cable (red) to positive (+) terminal of electrical source. Use procedure of Step 8 to determine correct terminal.

**10.** Connect one end of the negative (-) jump start cable to the negative (-) terminal of the electrical source.

**11.** Make final connection of negative (-) cable to frame of the stalled machine (not battery negative (-) post) away from battery, fuel or hydraulic lines, or moving parts.

**12.** Start the engine on the electrical source machine. Or, energize the charging system on the auxiliary power source.

**13.** Wait a minimum of two minutes for the batteries in the stalled machine to partially charge.

**14.** Attempt to start the stalled engine. Refer to section on Engine Starting.

**15.** Immediately after starting the stalled engine, disconnect the jump start cables in reverse order.

**16.** Conclude failure analysis on starting/charging system of stalled machine as required now that engine is running and charging system is in operation.

### Engine Starting with Auxiliary Start Receptacles

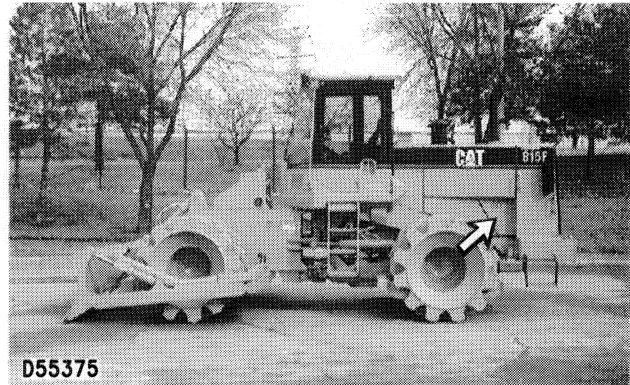

Located on the right side of the machine.

Some Caterpillar products may be equipped with auxiliary start receptacles as standard. All other machines can be equipped with a parts service receptacle. A permanent receptacle is then always available for auxiliary starting.

Two mating cable assemblies are also available to auxiliary start the stalled machine from another machine also equipped with this receptacle or an auxiliary power pack. Your Caterpillar dealer can provide the correct cables in lengths for your application.

**1.** Make initial determination as to failure of the stalled machine to crank. Refer to special instruction SEHS7768 on use of 6V2150 Starting/Charging Analyzer Group. Procedure applies even if machine does not have diagnostic connector.

**2.** Move the transmission control into NEUTRAL on the stalled machine. Engage the parking brake. Lower the attachment to the ground. Move all controls to HOLD.

**3.** Turn the start switch key to OFF on the stalled machine. Turn off all accessories.

**4.** Turn on (close) the disconnect switch (if equipped) on the stalled machine.

**5.** Move the boost start machine near enough to the stalled machine for cables to reach, but DO NOT ALLOW MACHINES TO TOUCH.

**6.** Stop the engine on the boost machine, or if using an auxiliary power source, turn off the charging system.

7. On the stalled machine connect the appropriate auxiliary starting cable to the auxiliary start receptacle.
8. Connect the other end of this cable to the auxiliary start receptacle of the electrical source.
9. Start the engine on the boost machine. Or, energize the charging system on the auxiliary power source.
10. Wait a minimum of two minutes for the batteries in the stalled machine to partially charge.
11. Attempt to start the stalled engine. Refer to the beginning of Engine Starting in this section.
12. Immediately after starting the stalled engine, disconnect the auxiliary starting cable from the ELECTRICAL SOURCE.
13. Disconnect the other end of this cable from the stalled machine.
14. Conclude failure analysis on starting/charging system of the stalled machine as required, now that engine is running and charging system is in operation.

### After Starting the Engine



---

#### NOTICE

Keep engine speed low until the engine oil pressure registers on the gauge or the engine oil indicator light goes out. If it does not register or the light goes out within ten seconds, stop the engine and investigate the cause before starting again. Failure to do so, can cause engine damage.

---

1. Allow a cold engine to warm up at LOW IDLE for at least five minutes. Engage and disengage the attachment controls to help speed warm up of hydraulic components.
2. Look at the indicators and gauges frequently during operation.

Also, to speed hydraulic oil warm up, hold the blade control in the CLOSE position for short periods, not more than ten seconds.

This will allow the oil to reach relief pressure, which causes it to warm more rapidly.

Cycle all controls to allow warm oil to circulate through all cylinders and lines.

When idling the engine for warm up, observe the following recommendations:

- In temperatures above 0°C (+32°F), warm-up requires approximately 15 minutes.
- In temperatures below 0°C (+32°F), warm-up requires approximately 30 minutes or more.
- In temperatures below -18°C (0°F) or if hydraulic functions are sluggish, more time may be required.

## Machine Operation

Be sure no one is working on or near the machine to prevent injury. Keep the machine under control at all times to prevent injury.

Reduce engine speed when maneuvering in tight quarters or when breaking over a rise.

Select the gear speed necessary before starting downgrade. Do not change gears while going downhill.

A good practice is to use the same gear speed going downgrade that would be used to go up the grade.

Do not allow the engine to overspeed downhill. Use the service brake pedal to reduce engine overspeed going downhill.

When the load will be pushing the machine, put the transmission selector lever in FIRST speed before starting downhill.

1. Adjust the operator's seat.
2. Fasten the seat belt.
3. Raise all lowered attachments enough to clear any obstructions.

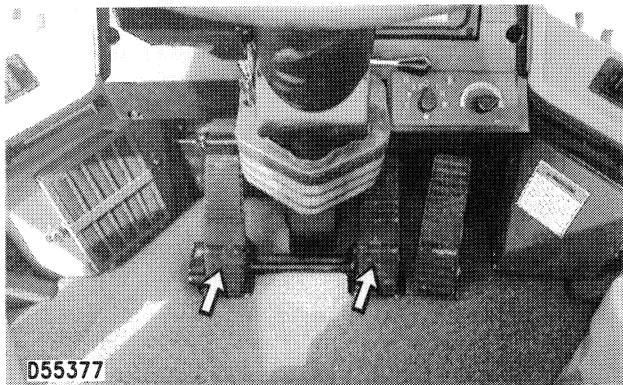

4. Push down on the service brake pedal to keep the machine from moving.

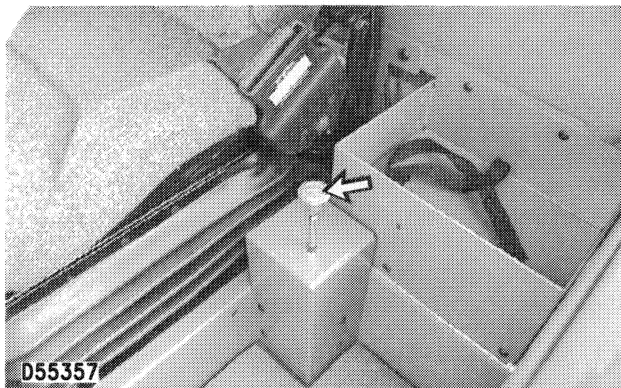

5. Push the parking brake knob in to release the parking brake.
6. Move the transmission control lever to the desired direction and gear speed.
7. Release the service brake pedal.
8. Push down on the accelerator pedal to the desired engine speed.
9. Drive the machine forward for best visibility and control.

---

### NOTICE

For operator comfort and maximum service life of power train components, deceleration and/or braking is recommended before any directional shifts are made.

---

## Parking Brake System

### **WARNING**

Personal injury could result from the sudden stop of the machine. The parking brake is automatically engaged when brake oil pressure drops below an adequate operating pressure.

If the brake system oil pressure drops below normal operating pressure, an action alarm will sound and the parking brake alert indicators on the operator's panel will flash. The action light will start flashing.

If the pressure drops further, the parking brake will engage automatically.

Be prepared for a sudden stop. Correct the reason for the loss of air pressure. Do not move the machine without normal brake oil pressure.

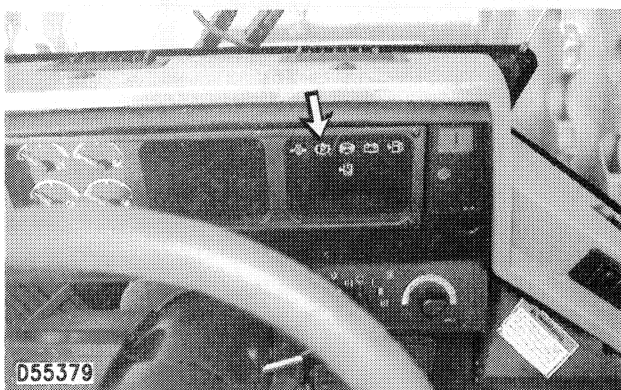

Loss of brake oil pressure will cause the brake alert indicators on the operator panel to flash. Loss of oil pressure will cause the parking brake to automatically engage and stop the machine.

The action light will also flash when the monitor system lights flash.

### **NOTICE**

Moving the machine with the parking brake engaged can cause excessive wear or damage to the brake. If necessary, have the brake repaired before operating the machine.

## Operating Techniques

### Straight Dozing – (Typical Example)

Heavy Dozing:

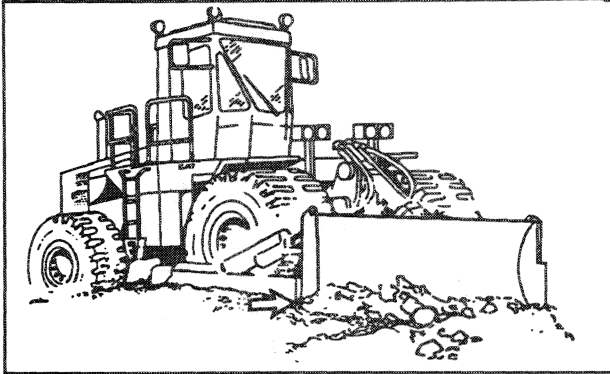

Tip the blade back so the skid shoe is flat on the ground. A channel will be formed by losses from the side of the blade.

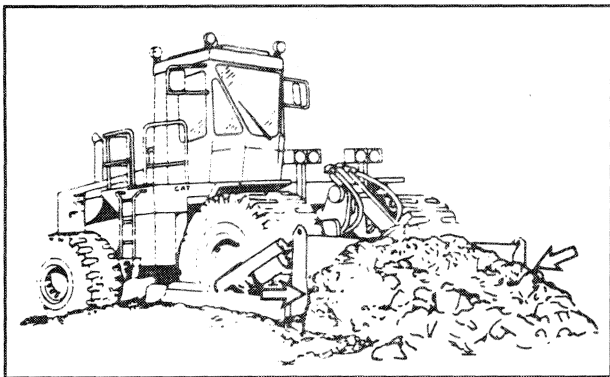

Move succeeding loads in this channel to reduce spilling. If the load slows the machine, downshift and/or raise the blade slightly.

If the blade digs in and raises the rear of the machine, raise the blade and keep the cut even.

Light Dozing:

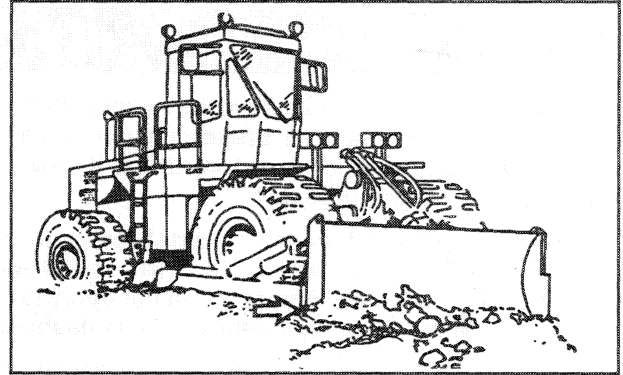

Keep the skid shoe flat on the ground to prevent the blade from being sucked into the ground.

Slot Dozing:

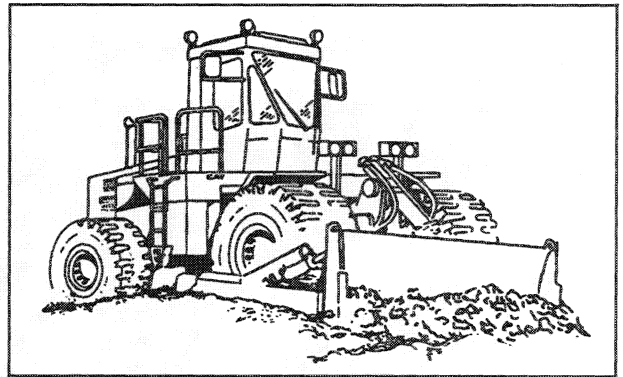

Doze a slot the width of the blade, deep enough to prevent material from spilling at the sides. Use this technique for stockpiling and high production.

NOTE: A full blade handles easier than a partially loaded blade when finishing or leveling.

**Stockpiling:**

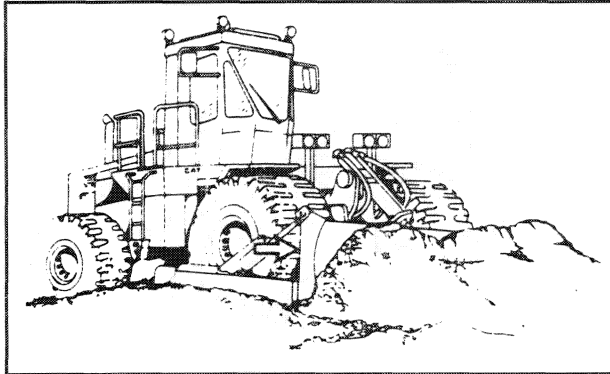

Standard blades as well as special design blades can be used.

**Ditching – (Typical Example)**

**Shallow “V” Ditches:**

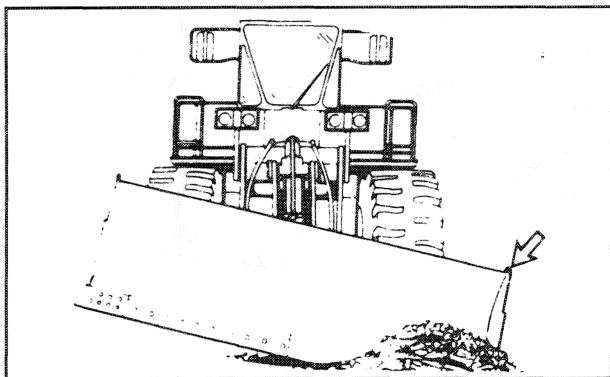

Tilt the blade so the low corner will remove enough material to leave a smooth path for the tires.

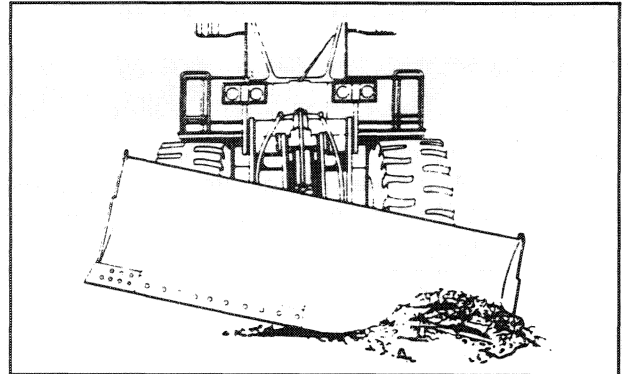

Repeat passes to obtain the desired depth. Spread the windrow. Clean existing ditches in the manner.

**Large Ditches:**

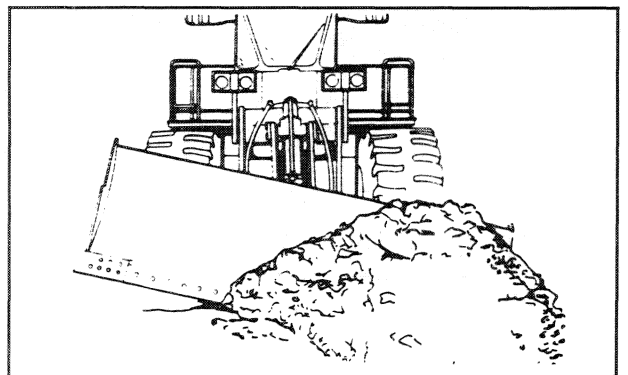

Establish the ditch line. Doze at right angles to the center line of the ditch.

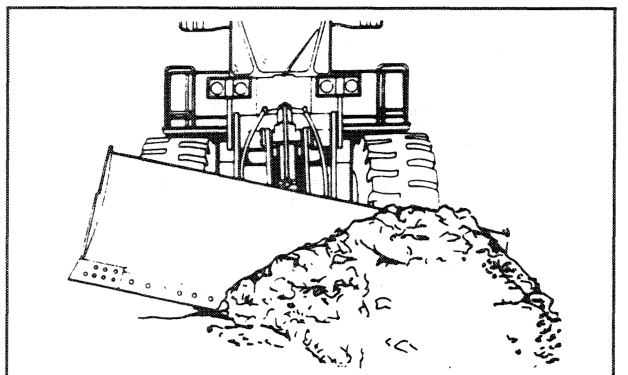

Doze the length of the ditch to smooth the sides and bottom after the desired depth has been reached.

### Tree or Brush Removal – (Typical Example)

 **WARNING**

Personal injury can result if the following is not adhered to. Back away immediately when the tree starts to fall. Do not drive on the stump while the tree is falling.

#### Trees:

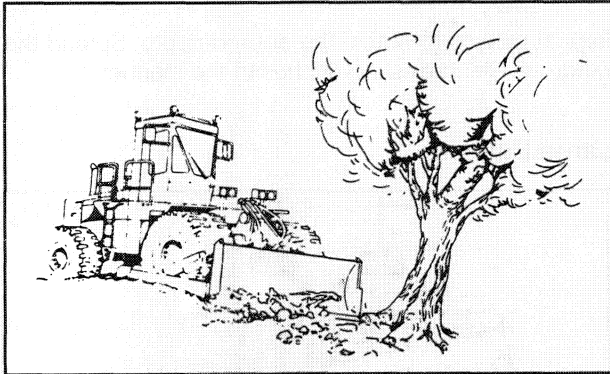

1. Remove dead limbs. Cut the roots on the side opposite the direction of fall. Cut the roots on the sides parallel to the direction of fall.

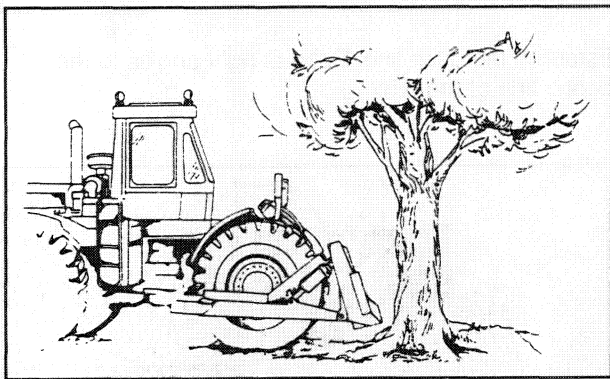

2. Ease into the tree. Push in the direction of fall with the blade high. Build an earth ramp if higher contact is needed.

#### Small Trees or Large Brush:

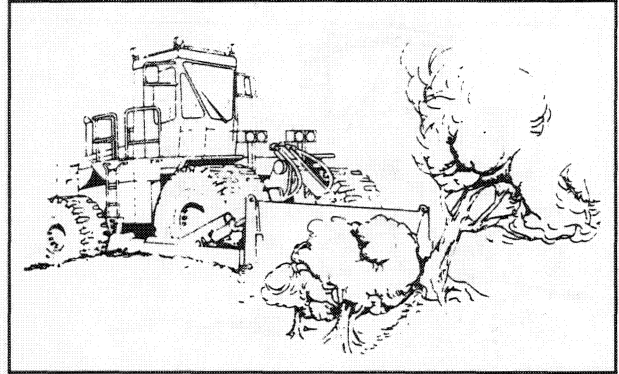

Make contact 30 to 40 cm (12 to 16 inches) above the ground. Move forward while lifting the blade.

#### Small Brush:

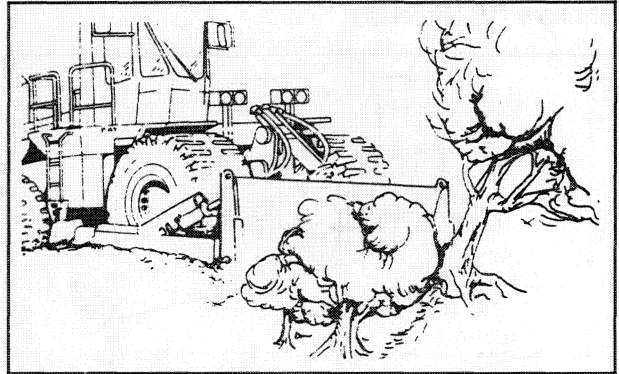

Lower the blade into the ground and move forward. Lift the blade when the brush is out to remove the earth from the roots.



### Side Hill Cut - (Typical Example)

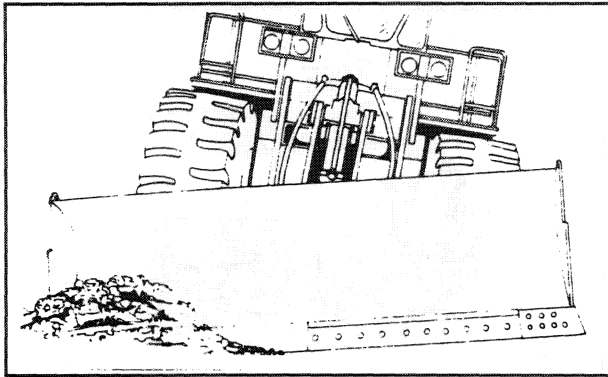

Tilt the blade down on the uphill side of the cut to form a level bench.

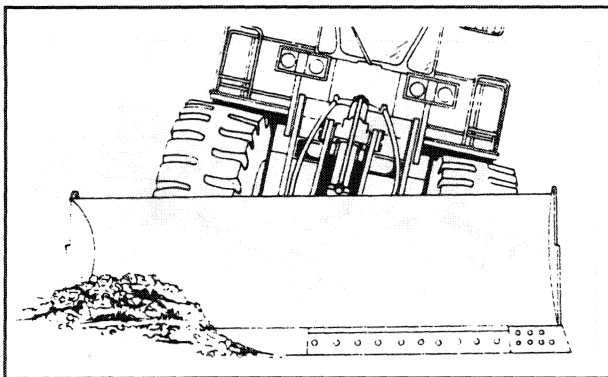

Cut the bench wide enough for the machines that will follow.

Make the starting cut with a series of downhill cuts, if necessary.

### Compacting - (Typical Example)

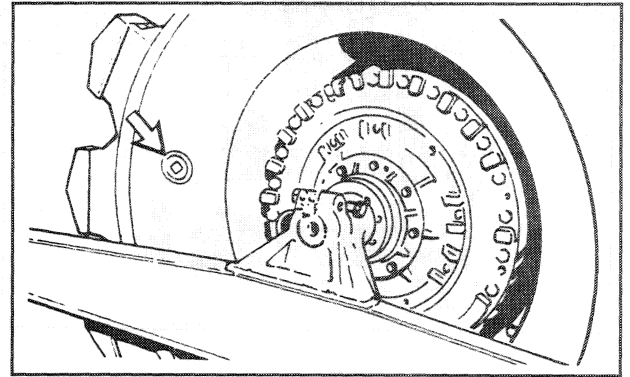

1. Increase or decrease ballast to bring the machine to the desired compacting weight.

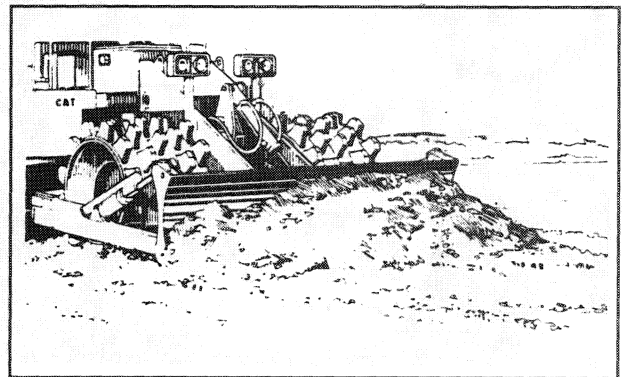

2. Lower the blade to ground level. Doze and compact in line with the fill area.

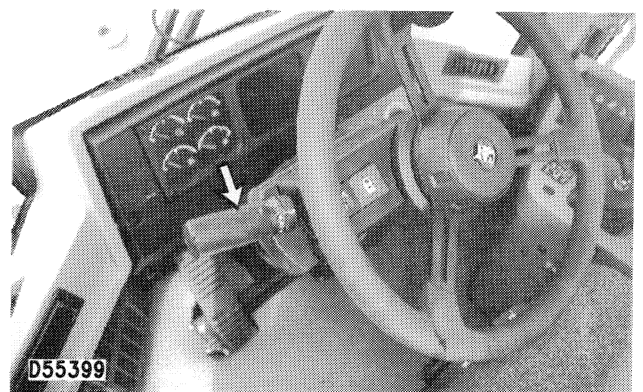

3. Move the transmission selector to SECOND speed. If the engine slows, use FIRST speed.

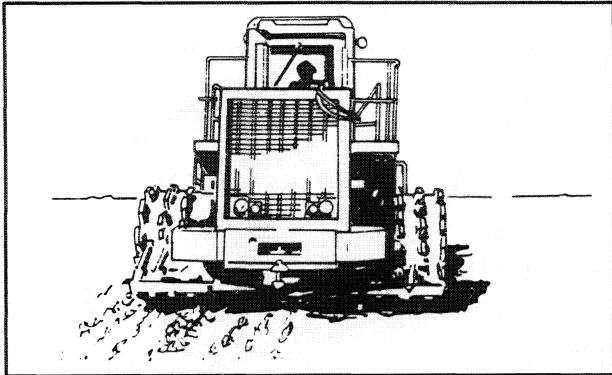

4. When at the end of the fill area, reverse the direction of the machine and straddle the previous tracks made by the compactor.

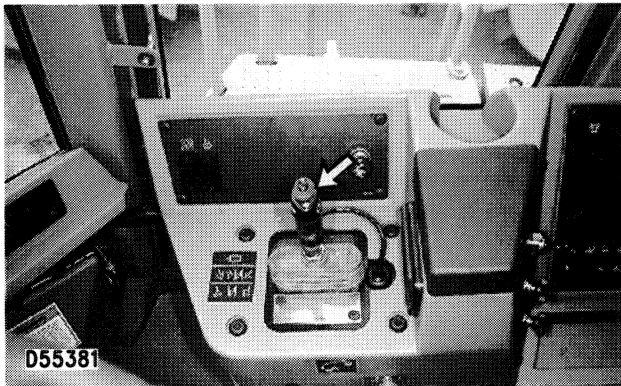

5. To help level the fill area, while moving backwards, move the blade control to the FLOAT position.

### Landfill Compacting – (Typical Example)

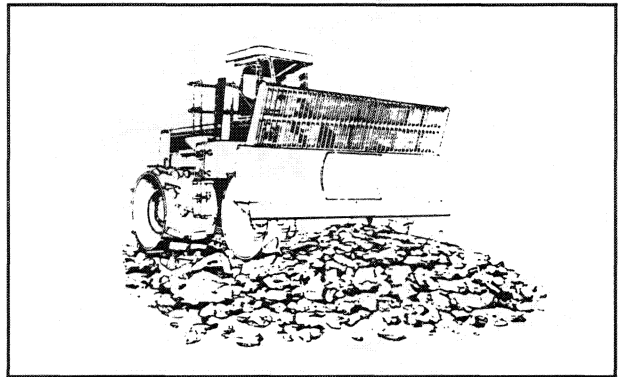

Raise the blade approximately 50 cm (18 inches) above ground level. This prevents material from being forced under the machine.

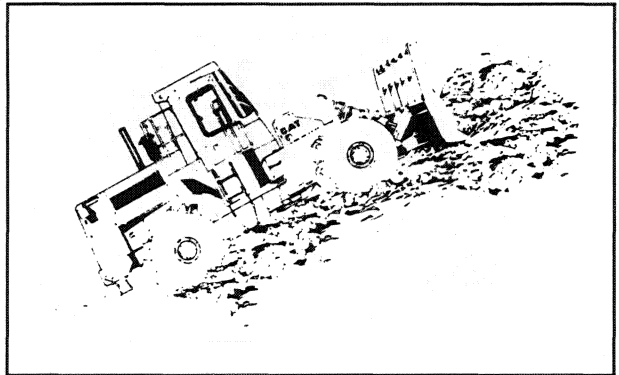

Work on a 3:1 slope for best compaction. If at all possible, the compactor should work uphill.

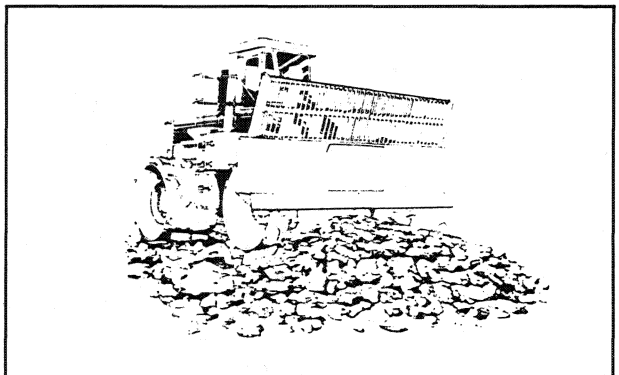

Three to five passes generally will give adequate compaction.

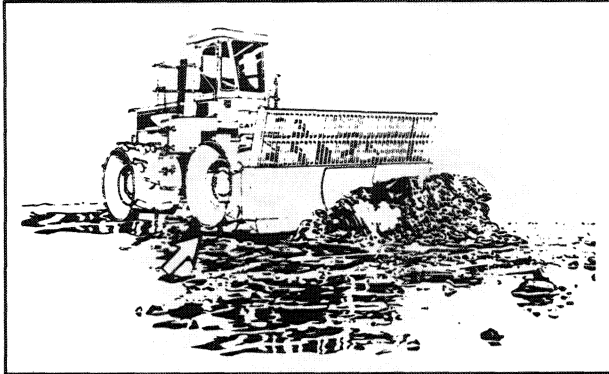

Compact large bulky items such as water heaters, refrigerators, stoves, etc., before dozing them into place. Compact these items with the outside edge of the front wheels.

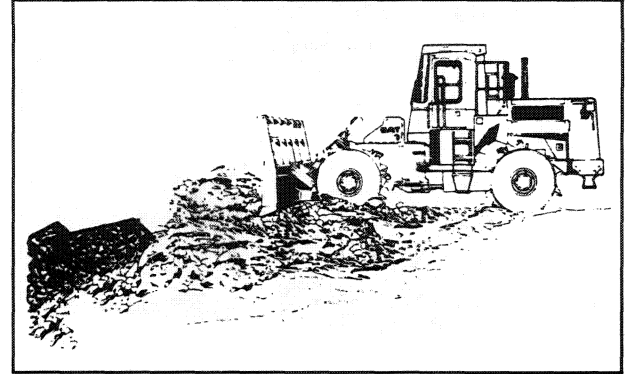

Place bed springs and other wire on the bottom of the slope without compaction. Spread and compact other material on top of these items.

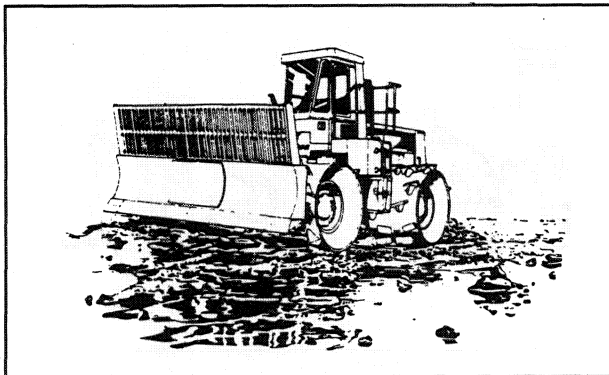

Straddle previous tracks, made by the compactor, to achieve complete coverage of the fill area, when returning from the end of the fill.

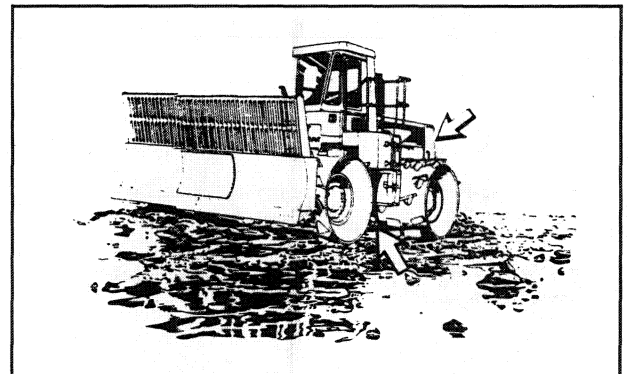

**WARNING**

**Personal injury or death can result from fires. Inspect the machine periodically for accumulation of debris and paper. Remove the accumulation to prevent engine overheating and fires.**

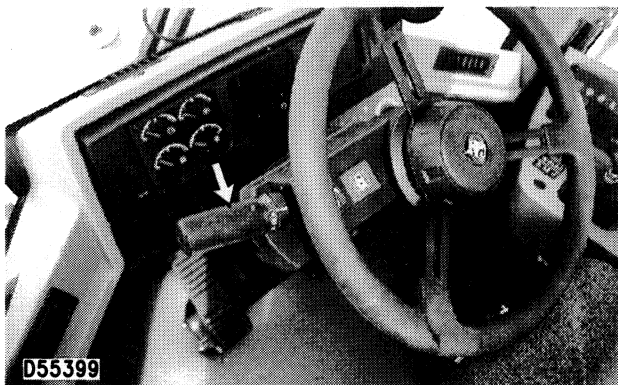

When compacting, operate in second gear. In soft underfoot conditions, operate the machine in first gear.

**Push Loading – (Typical Example)**

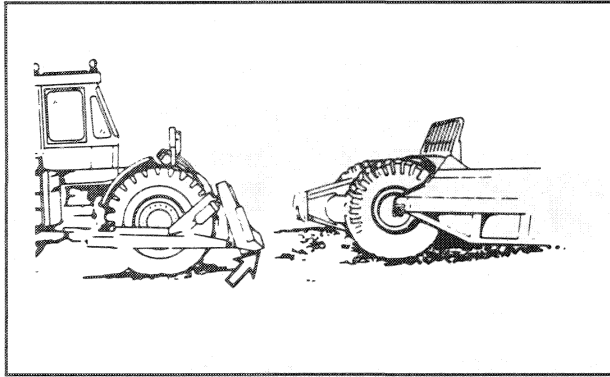

**1.** Position the cutting edge slightly above the ground level.

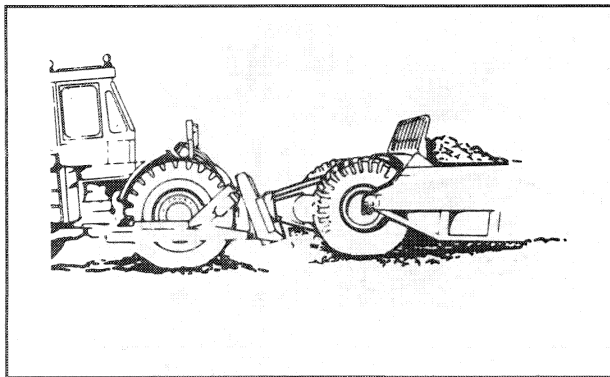

**2.** Match the travel speed of the scraper as near as possible when making contact.

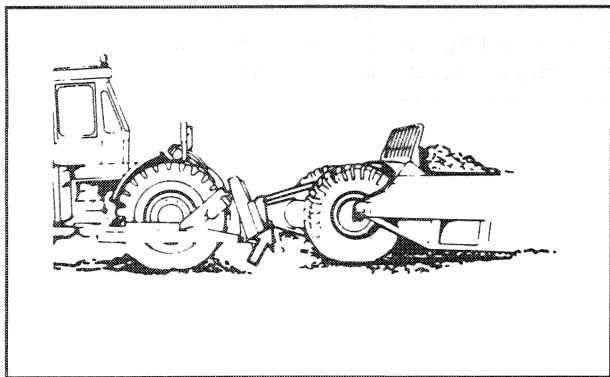

**3.** Contact the push block squarely. Keep the blade or push cup from contacting the scraper tires.

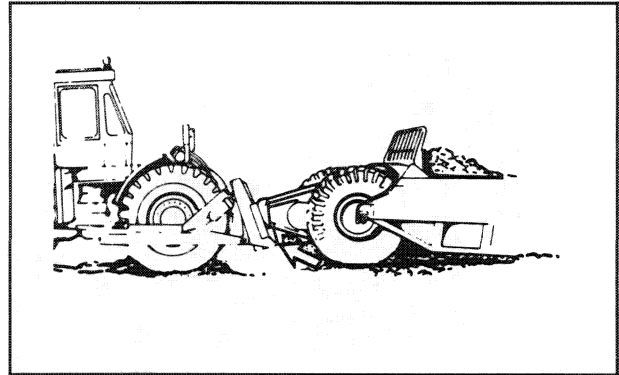

**4.** Tip the blade back to transfer the scraper weight to the tractor, but only enough to help eliminate tire slippage.

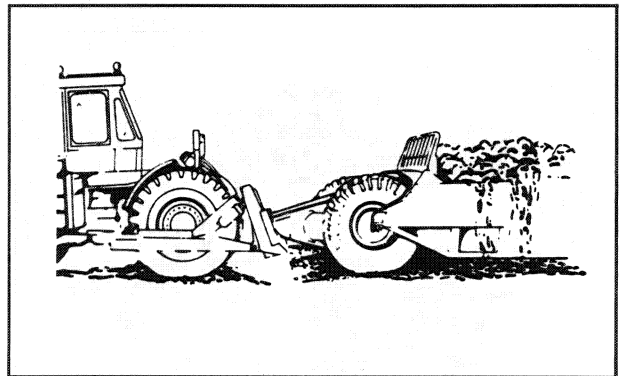

**5.** Upshift the tractor, when cut is complete, to help the tractor pick up speed.

**6.** When tandem pushing, the front tractor must be equipped with a case mounted push block.

## Machine Parking

### Machine Stopping

#### NOTICE

Park on a level surface. If it is necessary to park on a grade, block the wheels securely.

Engage the parking brake. Do not engage the secondary brake while the machine is moving unless the primary service brakes fail.

1. Apply the service brakes to stop the machine.

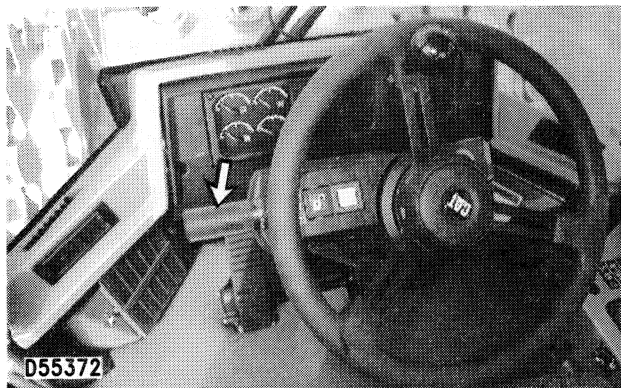

2. Move the transmission control lever into NEUTRAL.

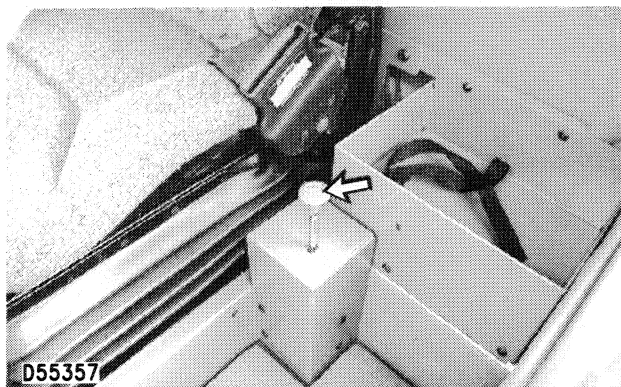

3. Engage the parking brake.
4. Lower the dozer blade to the ground and apply a slight down pressure.

### Engine Stopping

#### NOTICE

Stopping the engine immediately after it has been working under load, can result in overheating and accelerated wear of the engine components.

Refer to the following stopping procedure, to allow the engine to cool, and to prevent excessive temperatures in the turbocharger center housing, (if equipped) which could cause oil coking problems.

1. With the machine stopped, run the engine for five minutes at LOW IDLE. Stopping the engine immediately after it has been working under load, can result in overheating and accelerated wear of the engine components.

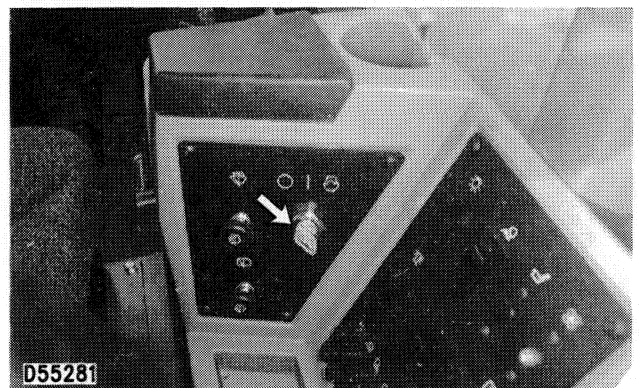

2. Turn the start switch key to OFF and remove the key.

## Leaving the Machine

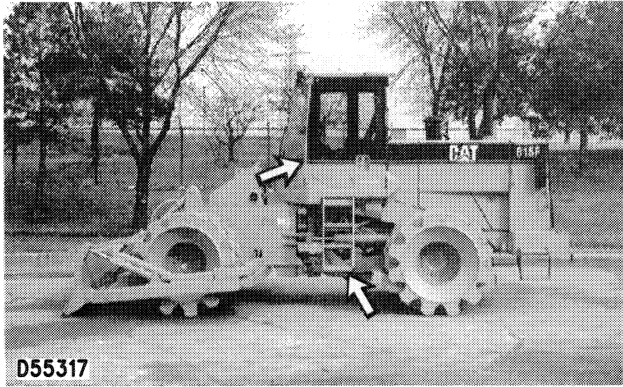

**1.** Use the steps and handholds, use both hands and face the machine, when dismounting. Make sure the steps are clear of debris before dismounting.

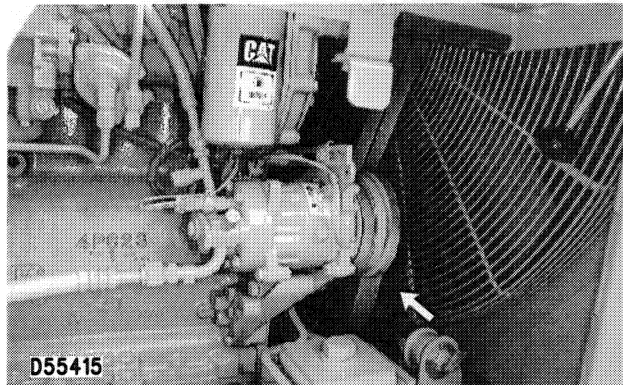

- 2.** Inspect the engine compartment for debris. Clean out any debris and paper to avoid a fire.
- 3.** Remove all flammable debris from front bottom guard through the access doors to reduce fire hazard. Dispose of debris properly.
- 4.** Turn the battery disconnect switch key to OFF and remove the key when leaving the machine for an extended period of a month or longer. This will prevent battery drain by short circuits or current draw made by some of the components, or by vandalism.
- 5.** Install all vandalism protection covers and locks.

## Transportation Information

### Machine Shipping

Investigate the travel route for overpass clearances. Make sure there will be adequate clearance for the machine being transported.

To prevent the machine from slipping while loading, or shifting in transit, remove ice, snow or other slippery material from the loading dock and the truck bed before loading.

---

#### NOTICE

Obey all state and local laws governing the weight, width and length of a load.

Remove the starting aid (ether) cylinder, if equipped.

Make sure the cooling system has proper antifreeze if moving machine to a colder climate.

Observe all regulations governing wide loads.

---

1. Block the trailer or rail car wheels before loading.
2. After the machine is in position, connect the steering frame lock link to hold the front and rear frames rigid.
3. Lower the attachment to the floor of the transport vehicle. Move the transmission control lever to NEUTRAL.
4. Engage the parking brake.
5. Stop the engine.
6. Turn the start switch key to OFF and remove the key.
7. Turn the disconnect switch key to OFF and remove the key.
8. Lock the door, access covers and attach any vandalism protection.
9. Secure the machine with tie-downs when transporting on a rail car or a tractor-trailer.
10. Cover the exhaust opening. Turbocharger (if equipped) damage can result if turbocharger rotates without the engine operating.

### Machine Rooding

Before rooding a machine, consult your tire dealer for recommended tire pressures and speed limitations.

"TON km/h" (TON MPH) limitations must be observed. Consult your tire dealer for the speed limit of the tires involved.

When traveling long distances, stop every 40 km (25 miles) or 1 hour for 30 minutes to allow the tires and components to cool.

Inflate the tires to the correct pressure.

Use a self-attaching inflation chuck and stand behind the tire tread while inflating the tire. See Tire Inflation Information.

Perform a Walk-Around Inspection and measure the fluid levels in the various compartments.

Check with the proper officials to obtain the required permits, etc.

Travel at a moderate speed. Observe all speed limitations when rooding the machine.

### Machine Lifting/Tie-down Information

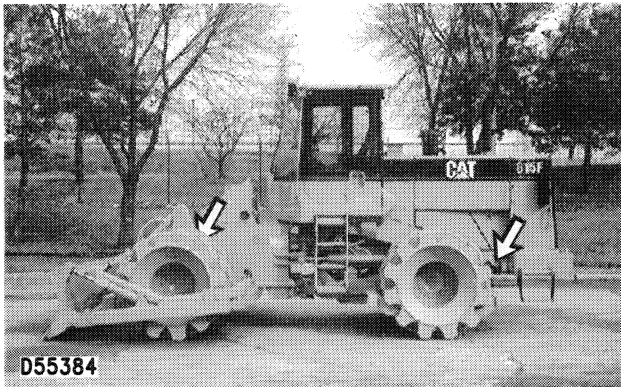

---

#### NOTICE

Improper lifting or tie-downs can allow load to shift and cause injury or damage.

---

**1.** Weight and instructions given herein apply to units manufactured by Caterpillar Inc.

814F Weight 18 611 kg (40,944 lb)

815F Weight 20 879 kg (45,933 lb)

816F Weight 22 779 kg (50,114 lb)

**2.** Use proper rated cables and slings for lifting. Position crane for level machine lift.

**3.** Spreader bar widths should be sufficient to prevent contact with machine.

**4.** Use the two rear and two front holes provided for tie-downs.

Install tie-downs at several locations, and block wheels front and rear.

Check appropriate laws governing weight, width and length of load.

Contact your Caterpillar dealer for shipping instructions for your machine.



## Towing Information

### **WARNING**

**Personal injury or death could result when towing a disabled machine incorrectly.**

**Block the machine to prevent movement before releasing the brakes. The machine can roll free if it is not blocked.**

**Follow the recommendations below, to properly perform the towing procedure.**

This machine is equipped with spring applied, oil pressure released brakes. If the engine or the oil pressure system are inoperable, the brakes are applied and the machine cannot be moved.

These towing instructions are for moving a disabled machine a short distance, only a few meters (feet) at low speed, no faster than 2 km/h (1.2 mph), to a convenient location for repair. These instructions are for emergencies only. Always haul the machine if long distance moving is required.

Shielding must be provided on both machines, to protect the operator if the tow line or bar should break.

Do not allow an operator on the machine being towed, unless the operator can control the steering and/or braking.

Before towing, make sure the tow line or bar is in good condition and has enough strength for the towing situation involved. Use a towing line or bar with a strength of at least 1.5 times the gross weight of the towing machine, for a disabled machine stuck in mud or when towing on a grade.

When towing, attach the tow line only to the tow eyes on the frame, if equipped.

Do not use a chain for pulling. A chain link can break causing possible personal injury. Use a wire rope cable with loop or ring ends. Use an observer in a harmless position to stop the pulling procedure if the cable starts to break or unravel. Stop pulling whenever the pulling machine moves without moving the towed machine.

Keep the tow line angle to a minimum. Do not exceed a 30° angle from the straight ahead position.

Quick machine movement could overload the tow line or bar and cause it to break. Gradual and smooth machine movement will work better.

Normally, the towing machine should be as large as the disabled machine. Satisfy yourself that the towing machine has enough brake capacity, weight and power, to control both machines for the grade and distance involved.

To provide sufficient control and braking when moving a disabled machine downhill, a larger towing machine or additional machines connected to the rear could be required. This will prevent it from rolling uncontrolled.

All different situation requirements cannot be given, as minimal towing machine capacity is required on smooth level surfaces to maximum on inclines or poor surface conditions.

Any towed machine, when loaded, must be equipped with its own brake system operable from the operator's compartment.

Consult your Caterpillar dealer for towing a disabled machine.

### **Engine Running**

If the power train and the steering system are operable, and the engine is running, the machine can be towed a **SHORT DISTANCE**, pulled out of mud or to the side of the road.

The operator on the towed machine **MUST** steer in the direction of the tow line.

Make certain, that all instructions outlined in this topic Towing Information are carefully and exactly followed.

### Engine Stopped

Perform the following steps before towing the machine with the engine stopped.

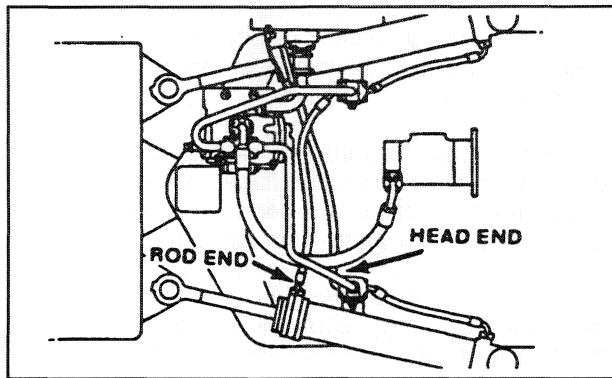

1. Reverse the hydraulic steering hose connections **ON ONE CYLINDER ONLY**, so the steering cylinders can move freely.

---

#### NOTICE

Be sure the cylinder hoses are connected correctly before operating the machine. With the hoses reversed, the steering system will not function.

---

2. If internal transmission or drive line failure is suspected, remove the drive shafts.

Refer to your Caterpillar dealer or to the Service Manual for drive shaft removal and installation procedures.

---

#### **WARNING**

**When the drive shafts are removed, the machine has NO parking brakes. The machine can roll and cause personal injury or death.**

**Block the wheels securely so that the machine cannot move.**

**If the brakes are in good operating condition, the machine has limited wheel brake ability. The pedal effort is high due to the lack of the hydraulic boost.**

**The towing connection must be rigid, or towing must be done by two machines of the same size or larger than the towed machine. Connect a machine on each end of towed machine.**

---

3. Release the parking brake.

---

#### NOTICE

Release the parking brake to prevent excessive wear and damage to the parking brake system, when towing without brake air pressure.

The procedure for manual release of the parking brake is outlined in the next topic, Manual Release of the Parking Brake.

---

4. Inspect the machine for power train damage. Remove all four drive shafts if damaged is suspected.
5. Fasten the tow bar.
6. Remove the wheel blocks. Tow the machine slowly. Do not tow any faster than 2 km/h (1.2 mph).

---

#### **WARNING**

**Personal injury or death can result from a brake malfunction.**

**Make sure all necessary repairs and adjustments have been made before a machine that has been towed to a service area, is put back into operation.**

---

## Manual Release of Parking Brake

**WARNING**

**Personal injury or death can result from a brake malfunction.**

**Do not operate the machine if the brake was applied due to a malfunction of the oil system, air system or the brake.**

**Correct any problem before attempting to operate the machine.**

---

1. Block the wheels to keep the machine from rolling when the parking brake is released.
2. Connect the steering frame lock link to the front and rear frames.

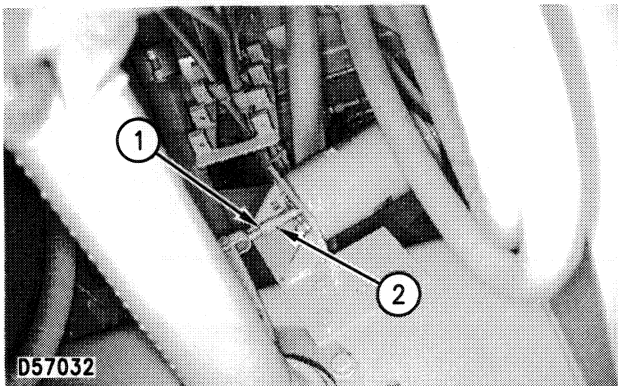

3. Loosen locknut (1) 18 mm (.75 in). Turn rod (2) until the rod moves out enough to totally release the parking brake.

---

### NOTICE

Before operating the machine, and after the parking brake has been serviced, adjust the parking brake. Refer to topic Brakes in the Every 250 Service Hours or Monthly section of this manual.

---

## Attachment Lowering With Engine Stopped

NOTE: With the engine stopped, the attachments can be lowered to the ground by moving the lift lever to the LOWER position.

### Maintenance Level

Operator instructions provide the Operator/Crew with data for operating the equipment including location and use of controls and indicators, how to prepare the equipment for use, and how to operate the equipment under ordinary, unusual and emergency conditions.

### Fire Extinguisher

A fire extinguisher is available at the Commanders discretion. See Appendix A, Additional Authorization List (AAL) for High Speed Self-Propelled Compactor.

### Interim Support Items List (ISIL)

List of support items required for maintenance in the period before requirements are established. See Appendix C.

### Durable/Expendable Supplies/Equipment

Approved fuels, Lubricants, Greases, and Oils for use on the Compactor. See Appendix D.

### Preventive Maintenance Checks and Services Operator.

Systematic care, inspection, and service of equipment to keep it in good condition and prevent breakdowns. See Appendix E.

### Maintenance Forms and Records

Operational, maintenance, and historical records will be maintained as required by the current DA PAM 738-750, The Army maintenance Management System (TAMMS).

## Tire Inflation Information

### Tire Inflation with Nitrogen (N<sub>2</sub>)

Caterpillar recommends using dry nitrogen (N<sub>2</sub>) gas for both tire inflation, and tire pressure adjustments on all rubber tired machines. Nitrogen is an inert gas and will not support combustion inside the tire.

### WARNING

**Proper nitrogen inflation equipment, and training in using the equipment, are necessary to avoid over inflation. A tire blowout or rim failure can result from improper or misused equipment and serious personal injury or death can occur.**

**Because a fully charged nitrogen cylinder's pressure is approximately 15 000 kPa (2200 psi), a tire blowout and/or rim failure can occur if the inflation equipment is not used correctly.**

In addition to reducing the risk of an explosion, using nitrogen to inflate tires lessens the slow oxidation of the rubber and the accompanying gradual tire deterioration. This is especially important for tires that have an expected long service life (four or more years). It also reduces the corrosion of rim components and the resultant disassembly problems.

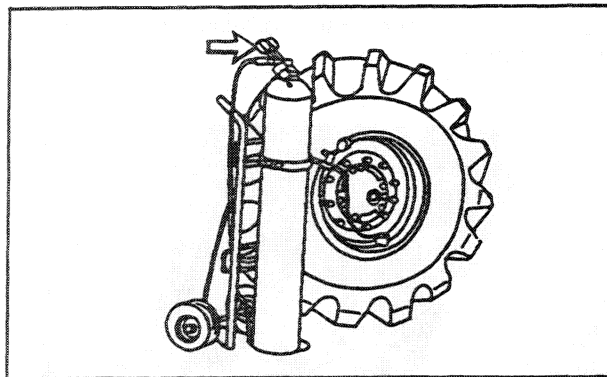

### WARNING

**Use a self-attaching inflation chuck and stand behind the tread when inflating a tire, to prevent possible personal injury.**

### NOTICE

Set the tire inflation equipment regulator at no more than 140 kPa (20 psi) over the recommended tire pressure.

Use only Caterpillar Part 6V4040 Nitrogen Tire Inflation Group, or equivalent, to inflate tires from a nitrogen gas cylinder. Refer to Special Instruction, form SMHS7867, for tire inflation instructions.

Use the same tire pressures for nitrogen inflation that are used for air inflation. Consult your tire dealer for operating pressures.

### Tire Shipping Pressure

The tire inflation pressures shown in the following chart are cold inflation shipping pressures.

| Size      | Ply Rating<br>or<br>Strength Index | Shipping<br>Pressure |     |
|-----------|------------------------------------|----------------------|-----|
|           |                                    | kPa                  | psi |
| 23.5 x 25 | 12                                 | 240                  | 35  |
| 23.5 x 25 | radial                             | 380                  | 55  |
| 26.5 x 25 | 14                                 | 240                  | 35  |
| 26.5 x 25 | radial                             | 310                  | 45  |

The operating inflation pressure is based on the weight of a ready-to-work machine without attachments, at rated payload, and in average operating conditions. Pressures for each application may vary and should always be obtained from your tire supplier.

### Tire Inflation Pressures Adjustment

A tire inflated in a warm shop area, 18°C to 21°C (65°F to 70°F), will be underinflated if the machine works in freezing temperatures. Low pressure shortens the life of a tire.

When operating in freezing temperatures, consult the Cold Weather Recommendations Operation and Maintenance Manual, form SEBU5898, for adjusted inflation pressures.

## Torque Specifications

For additional torque specifications, not included in this section, refer to Torque Specifications, SENR3130, available from your Caterpillar dealer.

### Torques for Ground Engaging Tool Bolts

| Bolt Size<br>Inch | Recommended Torque <sup>1</sup> |            |
|-------------------|---------------------------------|------------|
|                   | N•m                             | lb ft      |
| 5/8               | 270 ± 40                        | 200 ± 30   |
| 3/4               | 475 ± 60                        | 350 ± 45   |
| 7/8               | 750 ± 90                        | 550 ± 65   |
| 1                 | 1150 ± 150                      | 850 ± 110  |
| 1 1/4             | 2300 ± 300                      | 1700 ± 220 |

<sup>1</sup> These values are applicable only to Caterpillar cutting edge bolts.

### Torques for Standard Hose Clamps – Worm Drive Band Type

#### NOTICE

The following chart gives the torques for initial installation of hose clamps on new hose and for reassembly or retightening of hose clamps on existing hose.

| Clamp Width       | Initial Installation<br>Torque on New Hose |        |
|-------------------|--|--------|
|                   | N•m <sup>1</sup>                           | lb in  |
| 16 mm (.625 in)   | 7.5 ± 0.5                                  | 65 ± 5 |
| 13.5 mm (.531 in) | 4.5 ± 0.5                                  | 40 ± 5 |
| 8 mm (.312 in)    | 0.9 ± 0.2                                  | 8 ± 2  |
| Clamp Width       | Reassembly or<br>Retightening Torque       |        |
|                   | N•m <sup>1</sup>                           | lb in  |
| 16 mm (.625 in)   | 4.5 ± 0.5                                  | 40 ± 5 |
| 13.5 mm (.531 in) | 3.0 ± 0.5                                  | 25 ± 5 |
| 8 mm (.312 in)    | 0.7 ± 0.2                                  | 6 ± 2  |

<sup>1</sup> 1 Newton meter (N•m) is approximately the same as 0.1 mkg.

### Torques for Constant Torque Type Hose Clamps

For information on torque specifications for Constant Torque Hose Clamps, refer to Torque Specifications, SENR3130, available from your Caterpillar dealer.

### Torques for Standard Fasteners

#### NOTICE

The following charts give general torques for bolts, nuts and taperlock studs of SAE Grade 5 or better quality.

### Torques for Bolts and Nuts

| Thread Size<br>Inch | Standard Bolt & Nut Torque |            |
|---------------------|----------------------------|------------|
|                     | N•m <sup>1</sup>           | lb ft      |
| 1/4                 | 12 ± 3                     | 9 ± 2      |
| 5/16                | 25 ± 6                     | 18 ± 4.5   |
| 3/8                 | 47 ± 9                     | 35 ± 7     |
| 7/16                | 70 ± 15                    | 50 ± 11    |
| 1/2                 | 105 ± 20                   | 75 ± 15    |
| 9/16                | 160 ± 30                   | 120 ± 20   |
| 5/8                 | 215 ± 40                   | 160 ± 30   |
| 3/4                 | 370 ± 50                   | 275 ± 37   |
| 7/8                 | 620 ± 80                   | 460 ± 60   |
| 1                   | 900 ± 100                  | 660 ± 75   |
| 1 1/8               | 1300 ± 150                 | 950 ± 100  |
| 1 1/4               | 1800 ± 200                 | 1325 ± 150 |
| 1 3/8               | 2400 ± 300                 | 1800 ± 225 |
| 1 1/2               | 3100 ± 350                 | 2300 ± 250 |

<sup>1</sup> 1 Newton meter (N•m) is approximately the same as 0.1 mkg.

### Torques for Taperlock Studs

| Thread Size<br>Inch | Standard Taperlock Stud Torque |           |
|---------------------|--------------------------------|-----------|
|                     | N•m <sup>1</sup>               | lb ft     |
| 1/4                 | 8 ± 3                          | 6 ± 2     |
| 5/16                | 17 ± 5                         | 13 ± 4    |
| 3/8                 | 35 ± 5                         | 26 ± 4    |
| 7/16                | 45 ± 10                        | 33 ± 7    |
| 1/2                 | 65 ± 10                        | 48 ± 7    |
| 5/8                 | 110 ± 20                       | 80 ± 15   |
| 3/4                 | 170 ± 30                       | 125 ± 22  |
| 7/8                 | 260 ± 40                       | 190 ± 30  |
| 1                   | 400 ± 60                       | 300 ± 45  |
| 1 1/8               | 525 ± 60                       | 390 ± 44  |
| 1 1/4               | 750 ± 80                       | 550 ± 60  |
| 1 3/8               | 950 ± 125                      | 700 ± 92  |
| 1 1/2               | 1200 ± 150                     | 885 ± 110 |

<sup>1</sup> 1 Newton meter (N•m) is approximately the same as 0.1 mkg.

### Torques for Metric Fasteners

#### NOTICE

Be very careful never to mix metric with U.S. customary (standard) fasteners. Mismatched or incorrect fasteners will cause machine damage or malfunction and can result in personal injury.

Original fasteners removed from the machine should be saved for reassembly whenever possible. If new fasteners are needed, they must be of the same size and grade as the ones that are being replaced.

The material strength identification is usually shown on the bolt head by numbers (8.8, 10.9, etc.). The following chart gives standard torques for bolts and nuts with Grade 8.8.

NOTE: Metric hardware must be replaced with metric hardware. Check parts manual for proper replacement.

### Torques for Bolts and Nuts

| METRIC ISO <sup>2</sup> THREAD |                  |            |
|--------------------------------|------------------|------------|
| Thread Size<br>Metric          | Standard Torque  |            |
|                                | N•m <sup>1</sup> | lb ft      |
| M6                             | 12 ± 3           | 9 ± 2      |
| M8                             | 28 ± 7           | 20 ± 5     |
| M10                            | 55 ± 10          | 40 ± 7     |
| M12                            | 100 ± 20         | 75 ± 15    |
| M14                            | 160 ± 30         | 120 ± 20   |
| M16                            | 240 ± 40         | 175 ± 30   |
| M20                            | 460 ± 60         | 340 ± 40   |
| M24                            | 800 ± 100        | 600 ± 75   |
| M30                            | 1600 ± 200       | 1200 ± 150 |
| M36                            | 2700 ± 300       | 2000 ± 225 |

<sup>1</sup> 1 Newton meter (N•m) is approximately the same as 0.1 mkg.

<sup>2</sup> ISO—International Standard Organization.

### Torques for Taperlock Studs

| METRIC ISO <sup>2</sup> THREAD |                                |           |
|--------------------------------|--------------------------------|-----------|
| Thread Size<br>Metric          | Standard Taperlock Stud Torque |           |
|                                | N•m <sup>1</sup>               | lb ft     |
| M6                             | 8 ± 3                          | 6 ± 2     |
| M8                             | 17 ± 5                         | 13 ± 4    |
| M10                            | 35 ± 5                         | 26 ± 4    |
| M12                            | 65 ± 10                        | 48 ± 7    |
| M16                            | 110 ± 20                       | 80 ± 15   |
| M20                            | 170 ± 30                       | 125 ± 22  |
| M24                            | 400 ± 60                       | 300 ± 45  |
| M30                            | 750 ± 80                       | 555 ± 60  |
| M36                            | 1200 ± 150                     | 890 ± 110 |

<sup>1</sup> 1 Newton meter (N•m) is approximately the same as 0.1 mkg.

<sup>2</sup> ISO—International Standard Organization.

# Cooling System Specifications

## General Coolant Information

Many engine failures could be avoided with proper cooling system maintenance. Cooling system maintenance is as important as fuel and lubricating system maintenance. Coolant quality is as important as the quality of fuel and lubricating oil.

The three main functions that coolant serves are:

- Adequate heat transfer and anti-boil protection
- Cavitation erosion and corrosion protection
- Freeze protection

Coolant is normally composed of three elements:

- Water
- Additives
- Glycol

## Water

Distilled or deionized water is recommended for use in cooling systems. DO NOT use hard water, tap water, or salt softened tap water in engine cooling systems. If distilled or deionized water is NOT available, use water that meets the minimum acceptable requirements.

| MINIMUM ACCEPTABLE WATER |                       |
|--------------------------|-----------------------|
| Water Content            | Limits gr/3.8 L (ppm) |
| Chlorides                | 2.4 (40) maximum      |
| Sulfates                 | 5.9 (100) maximum     |
| Total Hardness           | 10 (170) maximum      |
| Total Solids             | 20 (340) maximum      |
| Acidity (pH)             | 5.5 to 9.0            |

ppm = parts per million

### NOTICE

Water that does not meet the minimum acceptable limits will reduce engine service life when used in cooling systems.

If you are not sure of the content of the water, contact your Caterpillar dealer, your local water department, your agricultural agent, or an independent laboratory to analyze the water.

## Additives

Additives must be included in all coolant mixtures. Additives help prevent the formation of rust, scale, and mineral deposits. Additives protect metals from corrosion, prevent liner cavitation, and contain anti-foaming agents. Additives are depleted during engine operation and need to be replenished. Additives can be replenished through the addition of supplemental coolant additives (used with conventional coolants) or Extender (used with Caterpillar Extended Life Coolant).

Nitrites or nitrite and molybdate additives protect the cylinder liner from cavitation corrosion. Nitrites are depleted, creating the need for additives or Extender. Additives and Extender also contain other inhibitors that can be depleted from cooling systems.

An insufficient additive concentration does not provide adequate protection for cooling systems. An excessive additive concentration can cause additives to drop out of the solution, deposit inside the cooling system, or form a gel in the radiator. Deposits can be in the form of sludge and scale which accumulate on hot engine surfaces. Deposits reduce cooling system effectiveness, or cause water pump leaks.

To maintain conventional cooling system protection, it is necessary to monitor supplemental coolant additive concentration. Maintain the proper additive levels in the cooling system.

## Glycol

Engine coolant glycol is normally either ethylene or propylene. Glycol raises the boiling point of water to help prevent boil-over, provides freeze protection, helps prevent water pump cavitation, and reduces cylinder liner pitting.

### NOTICE

For ambient temperatures requiring lower freeze protection (higher than 50 percent glycol), use ethylene glycol. DO NOT use propylene glycol.

Proper freeze/boil protection requires the proper ratio of glycol and acceptable water. Use the following charts to determine glycol concentrations to mix with acceptable water.



| ETHYLENE GLYCOL  |                        |                      |
|------------------|------------------------|----------------------|
| % Glycol/% Water | Protection             |                      |
|                  | Anti-Freeze<br>°C (°F) | Anti-Boil<br>°C (°F) |
| 30/70            | -15° (5°)              | 104° (219°)          |
| 40/60            | -24° (-12°)            | 106° (222°)          |
| 50/50            | -37° (-34°)            | 108° (226°)          |
| 60/40            | -57° (-62°)            | 111° (231°)          |

| PROPYLENE GLYCOL                  |                        |                      |
|-----------------------------------|------------------------|----------------------|
| Concentration<br>% Glycol/% Water | Protection             |                      |
|                                   | Anti-Freeze<br>°C (°F) | Anti-Boil<br>°C (°F) |
| 30/70                             | -15° (5°)              | 102° (216°)          |
| 40/60                             | -23° (-9°)             | 104° (219°)          |
| 50/50                             | -37° (-34°)            | 106° (222°)          |
| 60/40                             | -51° (-60°)            | 107° (225°)          |

Use the 1U-7298 Coolant Tester (°C) or the 1U-7297 Coolant Tester (°F) to check the coolant solution periodically to ensure adequate freeze/boil protection. The refractometers give immediate, accurate readings and can be used with ethylene or propylene glycol.

NOTE: For more detailed specifications, refer to: Know Your Cooling System, SEBD0518, and Coolant and Your Engine, SEBD0970, or contact your Caterpillar dealer.

### Coolant Recommendations

- Preferred – Caterpillar's Extended Life Coolant (ELC).
- Recommended – Caterpillar's Diesel Engine Antifreeze/Coolant (DEAC).
- Acceptable – Any low silicate coolant that meets Truck Maintenance Council (TMC) Recommended Practice (RP) 329, TMC RP330, or ASTM D4985 requirements when used with supplemental coolant additives.
- Permitted – A mixture of acceptable water and a supplemental coolant additive, where freeze protection is not necessary.

- Unacceptable – Any high silicate coolant that is classified as meeting ASTM D3306.

---

### NOTICE

Most commercial engine coolant/antifreezes are formulated for gasoline engine applications and have high silicate content. High silicates are conducive to cylinder liner cavitation and corrosion. Caterpillar DOES NOT recommend high silicate coolant/antifreezes.

---

NOTE: Due to individual engine applications, engine cooling system maintenance practices may need periodic evaluation.

---

### NOTICE

Never operate without thermostats in the cooling system. Thermostats maintain the engine coolant at the proper operating temperature. Cooling system problems can arise without thermostats.

---

### NOTICE

Never add coolant to an overheated engine. Allow the engine to cool first. Do not add coolant too quickly. Filling the cooling system at over 19 L (5 US gal) per minute can create air pockets in the cooling system. Engine damage can result.

---

When filling or adding coolant to the system, premix the coolant solution prior to pouring it into the cooling system. Pure, undiluted glycol will freeze at -23°C (-10°F). Use a coolant solution that is in a range which will provide protection to the lowest expected outside (ambient) temperature and provide the required boil-over protection.

## Caterpillar's Extended Life Coolant

Caterpillar's Extended Life Coolant anti-corrosion package is different from the conventional antifreezes that have been used. Extended Life Coolant is an ethylene glycol-based coolant/antifreeze containing organic corrosion inhibitors and anti-foam agents with fewer nitrites than conventional coolants.

Extended Life Coolant was specifically designed for use in diesel engine cooling systems and natural gas engine cooling systems.

Extended Life Coolant extends coolant life to 6000 service hours or four years, whichever comes first. One addition of Caterpillar's Extender is required to maintain Extended Life Coolant.

Major Extended Life Coolant advantages:

- Twice the coolant life
- Considerably less maintenance
- Improved corrosion protection
- Better aluminum protection
- Better liner protection
- Fewer additives (chemicals) and no chemical drop out
- Longer radiator life
- Increased water pump seal life

Extended Life Coolant is available as a 50 percent Extended Life Coolant and 50 percent deionized water solution or in concentrate. See the table for quantities that are available.

| CATERPILLAR EXTENDED LIFE COOLANT QUANTITIES AVAILABLE |                     |          |
|--|---------------------|----------|
| Type   | Size                | Part No. |
| Pre-mix <sup>1</sup>                                   | Bulk                | 119-5148 |
|  | 208.5 L (55 US gal) | 101-2845 |
|  | 3.8 L (1 US gal)    | 101-2844 |
| Concentrate <sup>2</sup>                               | 3.8 L (1 US gal)    | 119-5150 |

<sup>1</sup> 50 percent Extended Life Coolant and 50 percent deionized water.

<sup>2</sup> Extended Life Coolant/Antifreeze Concentrate is available ONLY to lower freeze protection. The Concentrate is not intended to be used as a mix.

NOTE: A 50 percent Extended Life Coolant and 50 percent deionized water solution provides freeze protection to  $-37^{\circ}\text{C}$  ( $-34^{\circ}\text{F}$ ) and anti-boil protection to  $108^{\circ}\text{C}$  ( $226^{\circ}\text{F}$ ). DO NOT use Extended Life Coolant at reduced concentrations (less than 50 percent), as the additives would be reduced along with the antifreeze. Extended Life Coolant concentrate is available to lower the coolant freeze point when used in arctic conditions. Extended Life Coolant concentration can be increased to 60 percent for  $-52^{\circ}\text{C}$  ( $-62^{\circ}\text{F}$ ) freeze protection.

## Extender

Extender should be added to the cooling system at the 3000 service hours or two years, whichever comes first. Add extender to the coolant to obtain a  $2.2 \pm 0.3\%$  extender concentration. See the following table to determine the recommended amount of Extender to add to Extended Life Coolant. Cat extender (119-5152) is available in .95 L (1 qt) bottles through your Caterpillar dealer. One bottle is the approximate amount needed to treat a cooling system with a capacity of 38-49 liters.

| RECOMMENDED AMOUNT OF EXTENDER BY COOLING SYSTEM CAPACITY |                                |
|---|--------------------------------|
| Cooling System Capacity                                   | Recommended Amount of Extender |
| 22 to 30 L (6 to 8 US gal)                                | 0.57 L (20 oz)                 |
| 30 to 38 L (8 to 10 US gal)                               | 0.71 L (24 oz)                 |
| 38 to 49 L (10 to 13 US gal)                              | 0.95 L (1 qt)                  |
| 49 to 64 L (13 to 17 US gal)                              | 1.2 L (40 oz)                  |
| 64 to 83 L (13 to 22 US gal)                              | 1.4 L (48 oz)                  |
| 83 to 114 L (22 to 30 US gal)                             | 1.9 L (64 oz)                  |
| 114 to 155 L (30 to 40 US gal)                            | 2.8 L (96 oz)                  |

## Extended Life Coolant Cooling System Maintenance

---

### NOTICE

Use only Caterpillar products or commercial products that have passed Caterpillar's EC-1 specification for premixed or concentrated coolants.

Use only Caterpillar Extender with Extended Life Coolant.

Mixing Extended Life Coolant with other products reduces the Extended Life Coolant service life. Failure to follow the recommendations included in this section can reduce cooling system component life.

---

In order to maintain the correct balance of antifreeze and additives, care should be taken to maintain the proper Extended Life Coolant concentration. Reducing the amount of antifreeze lowers the proportion of additive, thus lowering the coolant's ability to protect the cooling system from pitting, cavitation, erosion, and deposits.

### Proper Extended Life Coolant Additions

NOTE: DO NOT add Extended Life Coolant Concentrate as a makeup solution for routine cooling system top-off. Adding concentrated Extended Life Coolant increases the concentration of glycol in the cooling system.

During normal maintenance, use a premixed solution of approved water and Extended Life Coolant as a top-off to the cooling system to bring the coolant to the proper level. Use Extended Life Coolant or a coolant that meets Caterpillar's EC-1 specification. If a coolant that meets EC-1 is not available, use distilled or de-ionized water as a make-up. Check the glycol level of the cooling system with the 1U-7298 Coolant Tester (°C) or the 1U-7297 Coolant Tester (°F). Use Extended Life Coolant Concentrate to restore the proper glycol concentration before the engine is exposed to freezing temperatures.

---

### NOTICE

Do not use conventional coolant to top off a cooling system using Extended Life Coolant.

Do not use supplemental coolant additives other than extender in cooling systems filled with Extended Life Coolant.

---

If a cooling system using Extended Life Coolant has been topped off with a small amount of conventional coolant or if a supplemental coolant additive was added to the system by mistake, the system will not be harmed.

Should the cooling system become contaminated with conventional coolant or supplemental coolant additive exceeding 10 percent of the cooling system's total capacity, perform one of the following actions:

- Drain the cooling system and refill the cooling system with Extended Life Coolant, or
- Maintain the cooling system as if the cooling system is filled with conventional coolant.

## Extended Life Coolant Cooling System Cleaning

NOTE: No cleaning agents are to be used when a cooling system using Extended Life Coolant is drained, flushed, and refilled.

Clean water is the only system cleaning/flushing agent required when Extended Life Coolant is drained from the cooling system.

Extended Life Coolant can be recycled. The drained coolant mixture can be "distilled" to separate the ethylene glycol and water for reuse. Contact your Caterpillar dealer for more information.

After draining and refilling the cooling system, operate the engine with the radiator filler cap removed until the coolant reaches normal operating temperature and the coolant level stabilizes. Add coolant mixture as necessary to fill the system to the proper level.

**Converting a Cooling System from Conventional Coolant to Extended Life Coolant**

NOTE: When the coolant is changed from conventional coolant to Extended Life Coolant, a Caterpillar cleaner should be used. After the use of Caterpillar cooling system cleaners, the system MUST be thoroughly flushed with clean water.

To convert the cooling system from conventional coolant to Extended Life Coolant, perform the following procedure:

1. Drain the coolant.
2. Flush the system with clean water to remove any debris.
3. Use a Caterpillar cleaner to clean the system. Follow the instructions on the label. Caterpillar cleaner is available from your Caterpillar dealer.
4. Drain the cleaner. Flush the cooling system with clean water.
5. Fill the cooling system with clean water. Operate the engine until the cooling system temperature is 49 to 66°C (120 to 150°F).
6. Drain and flush the cooling system with clean water.
7. Repeat Step 5 and Step 6.
8. Fill the cooling system with Extended Life Coolant.
9. Attach a label to the cooling system to indicate the system has been converted to use Extended Life Coolant.

**Conventional Antifreeze/Coolant**

**Recommended – Caterpillar’s Diesel Engine Antifreeze/Coolant**

NOTE: The following information and recommendations are for Caterpillar’s Diesel Engine Antifreeze/Coolant only.

Caterpillar’s Diesel Engine Antifreeze/Coolant was specifically designed for diesel engine cooling systems and natural gas engine cooling systems. Diesel Engine Antifreeze/Coolant is an alkaline type, ethylene glycol-based formula containing inorganic corrosion inhibitors and anti-foam agents. Diesel Engine Antifreeze/Coolant was formulated with the correct additive levels to protect metal parts in diesel engines. Diesel Engine Antifreeze/Coolant will furnish adequate corrosion protection, anti-foam protection, and cylinder liner/block pitting protection. Use a 30 percent Diesel Engine Antifreeze/Coolant and 70 percent acceptable water/supplemental coolant additive solution.

Major advantages of Diesel Engine Antifreeze/Coolant:

- Minimal silicate content – High silicate coolants, used with supplemental coolant additives, can cause a build-up of solids over time. Build-up of solids can cause plugging, loss of heat transfer, and water pump seal damage. Diesel Engine Antifreeze/Coolant significantly reduces solid residue build-up that causes inhibitor dropout and water pump seal damage.
- No need to add supplemental coolant additive on initial fill – Supplemental coolant additive must be added with other commercially available coolants.

Diesel Engine Antifreeze/Coolant is available from your Caterpillar dealer in the following quantities:

| LIQUID SUPPLEMENTAL COOLANT ADDITIVE QUANTITIES AVAILABLE |                         |
|---|-------------------------|
| Part No.  | Size                    |
| 6V-3542   | 0.25 Liter (0.53 Pint)  |
| 8T-1589   | 0.47 Liter (1 Pint)     |
| 3P-2044   | 1.00 Liter (1.05 Quart) |
| 8C-3680   | 18.95 Liter (5 Gallons) |
| 5P-2907   | 208 Liter (55 Gallons)  |

### Proper Antifreeze Concentrations

Use the table to determine concentrations of Diesel Engine Antifreeze/Coolant to mix with acceptable water and supplemental coolant additive.

| ANTIFREEZE CONCENTRATIONS (GLYCOL) |                              |
|------------------------------------|------------------------------|
| Protection Temperature             | Concentration                |
| Protection to -15°C (5°F)          | 30% antifreeze and 70% water |
| Protection to -23°C (-9°F)         | 40% antifreeze and 60% water |
| Protection to -37°C (-35°F)        | 50% antifreeze and 50% water |
| Protection to -51°C (-60°F)        | 60% antifreeze and 40% water |

### Acceptable Antifreeze/Coolant

Any low silicate coolant that meets Truck Maintenance Council (TMC) Recommended Practice (RP) 329, TMC RP330, or ASTM D4985 requirements when used with supplemental coolant additives is acceptable.

Caterpillar recommends a minimum of 30 percent glycol to 70 percent water/supplemental coolant additive for proper corrosion protection. All Caterpillar engines with air-to-air aftercooling (ATAAC) require a minimum concentration of 30 percent glycol to prevent water pump cavitation.

While 30 percent glycol is the minimum acceptable volume, Caterpillar prefers a 50 percent glycol and 50 percent water/supplemental coolant additive mixture for optimum performance.

When using Diesel Engine Antifreeze/Coolant, no supplemental coolant additive is necessary on initial fill because supplemental coolant additive is in the Diesel Engine Antifreeze/Coolant. Supplemental coolant additive must be added with commercial coolants meeting ASTM D4985 at initial fill. Supplemental coolant additive must be replenished with both Caterpillar Diesel Engine Antifreeze/Coolant and other commercial coolants at regular service intervals. Refer to the chart for quantities of Caterpillar Liquid SCA to mix with ASTM D4985 commercial coolants at initial fill.

| LIQUID SUPPLEMENTAL COOLANT ADDITIVE<br>REQUIRED BY CAPACITY |   |  |
|--|---|--|
| Cooling System Capacity<br>Liters (US gal)                   | Amount At Initial Fill <sup>1</sup><br>Quantity <sup>2</sup> Or | Amount At 250 Hour<br>Maintenance <sup>2</sup> |
| 22 to 30 (6 to 8)  | 3P-2044 [1]   | 6V-3542 [1]                                    |
| 30 to 38 (8 to 10)   | 3P-2044 [1]<br>6V-3542 [1]                                      | 111-2372 [1]                                   |
| 38 to 49 (10 to 13)  | 3P-2044 [1]<br>8T-1589 [1]                                      | 111-2372 [1]                                   |
| 49 to 64 (13-17)   | 3P-2044 [2]   | 8T-1589 [1]                                    |
| 64 to 83 (17 to 22)  | 3P-2044 [2]<br>8T-1589 [1]                                      | 3P-2044 [1]                                    |
| 83 to 114 (22 to 30)   | 3P-2044 [3]<br>8T-1589 (1)                                      | 3P-2044 [1]                                    |
| 114 to 163 (30 to 44)  | 3P-2044 [5]   | 3P-2044 [1]<br>6V-3542 (1)                     |
| 163 to 243 (44 to 64)  | 3P-2044 [8]   | 3P-2044 [2]                                    |

Number in brackets [ ] indicates quantity required.

<sup>1</sup> Use only when not using Caterpillar Diesel Engine Antifreeze/Coolant on initial fill or refill.

<sup>2</sup> Do not exceed six percent maximum SCA concentration. Check concentration with SCA test kit.

**Supplemental Coolant Additive**



**Supplemental cooling system additive contains alkali. To prevent personal injury, do not drink, avoid contact with the skin and eyes.**

**NOTICE**

The cooling system **MUST** contain supplemental coolant additive for proper engine protection, regardless of antifreeze concentration.

**NOTICE**

**DO NOT** mix Caterpillar's supplemental coolant additive or coolant additive elements with another manufacturer's products. Select a cooling system treatment and use it exclusively.

Supplemental coolant additive is necessary for proper conventional coolant maintenance. Most coolant solutions **DO NOT** contain sufficient supplemental coolant additive for diesel engine application.

**NOTICE**

Do not exceed the recommended six percent supplemental coolant additive concentration. Excessive supplemental coolant additive concentration can form deposits on the higher temperature surfaces of the cooling system, reducing the engine's heat transfer characteristics. Reduced heat transfer could cause cracking of the cylinder head and other high temperature components. Excessive supplemental coolant additive concentration could also result in radiator tube blockage, overheating, and/or accelerated water pump seal wear. Never use both liquid supplemental coolant additive and the spin-on element (if equipped) at the same time. The use of those additives together could result in supplemental coolant additive concentration exceeding the recommended six percent maximum.

Use liquid supplemental coolant additive or a supplemental coolant additive element (if equipped) to maintain a three to six percent supplemental coolant additive concentration in the coolant.

NOTE: Caterpillar test kits check for concentration of nitrites in the coolant solution. Some manufacturers' supplemental coolant additive are phosphate based. Caterpillar test kits provide inaccurate results with phosphate based supplemental coolant additive. Commercial supplemental coolant additive products must contain silicates and a minimum of 70 grams per 3.8 L (1 US gal) (1200 ppm) nitrites. If another manufacturer's supplemental coolant additive is used, use that manufacturer's test kit. Follow the manufacturer's recommendations for cooling system treatment and test evaluation.

Test the coolant periodically to monitor supplemental coolant additive levels. Use the 4C-9301 Test Kit to check for Caterpillar supplemental coolant additive concentration. The kit also provides cooling system maintenance recommendations. This kit is specifically for use with Caterpillar supplemental coolant additive's. The 8T-5296 Test Kit can also to check for Caterpillar supplemental coolant additive concentration.

The tables lists the part numbers and quantities of supplemental coolant additive (liquid and solid) available from your Caterpillar dealer. Follow the instructions on the label.

| <b>LIQUID SUPPLEMENTAL COOLANT ADDITIVE<br/>REQUIRED BY CAPACITY</b> |   |
|--|---|
| <b>Cooling System<br/>Capacity<br/>Liters (US gal)</b>               | <b>Amount At<br/>250 Hour<br/>Maintenance<sup>1</sup></b> |
| 22 to 30 (6 to 8)  | 6V-3542 [1]   |
| 30 to 38 (8 to 10)   | 111-2372 [1]  |
| 38 to 49 (10 to 13)  | 111-2372 [1]  |
| 49 to 64 (13 to 17)  | 8T-1589 [1]   |
| 64 to 83 (17 to 22)  | 111-2372 [1]<br>6V-3542 [1]                               |
| 83 to 114 (22 to 30)   | 3P-2044 [1]   |
| 114 to 163 (30 to 44)  | 3P-2044 [1]<br>6V-3542 [1]                                |
| 163 to 242 (44 to 64)  | 3P-2044 [2]   |

Numbers in brackets [ ] are quantities required.  
<sup>1</sup> Do not use supplemental coolant additive element and supplemental coolant additive liquid at the same time. Do not exceed six percent maximum concentration. Check concentration with a supplemental coolant additive test kit.

| SUPPLEMENTAL COOLANT ADDITIVE ELEMENTS<br>REQUIRED BY CAPACITY |   |
|--|---|
| Cooling System<br>Capacity<br>Liters (US gal)                  | Amount At<br>250 Hour<br>Maintenance <sup>1</sup> |
| 22 to 30 (6 to 8)  | 111-2370 [1]                                      |
| 30 to 49 (8 to 13)   | 111-2369 [1]                                      |
| 49 to 64 (13 to 17)  | 9N-3368 [1]                                       |
| 64 to 83 (17 to 22)  | 111-2371 [1]                                      |
| 83 to 114 (22 to 30)   | 9N-3718 [1]                                       |
| 114 to 163 (30 to 44)  | 111-2371 [2]                                      |
| 163 to 242 (44 to 64)  | 9N-3718 [2]                                       |

Numbers in brackets [ ] are quantities required.

<sup>1</sup> Do not use supplemental coolant additive element and supplemental coolant additive liquid at the same time. Do not exceed six percent maximum concentration. Check concentration with a supplemental coolant additive test kit.

### Permitted-Water/Supplemental Coolant Additive

---

#### NOTICE

Never use water alone without supplemental coolant additive or inhibited coolant. Water alone is corrosive at engine operating temperatures.

---



---

#### NOTICE

A mixture of water and supplemental coolant additive does not protect against freezing or boiling.

---



---

#### NOTICE

A coolant mixture of water and supplemental coolant additive will cool and provide some protection to engine components, but it will NOT provide normal engine service life.

---



---

#### NOTICE

Caterpillar's recommendation for proper coolant is a minimum concentration of 30 percent glycol and 70 percent acceptable water and supplemental coolant additive (three percent of the total mixture). This recommendation will maintain cooling system corrosion protection.

---

In applications where freeze protection is not required, or where antifreeze is not available, a coolant mixture of acceptable water and supplemental coolant additive can be used. A water/supplemental coolant additive system should maintain a six to eight percent supplemental coolant additive concentration. DO NOT exceed eight percent maximum supplemental coolant additive concentration. Supplemental coolant additive concentration levels must be monitored.

The 8T-5296 Test Kit can be used to evaluate the supplemental coolant additive concentration in water/supplemental coolant additive coolant, with the following modifications to label instruction Step 3 and Step 5.

STEP 3. - Add tap water to the vial up to the 20 ml mark.

STEP 5. - With the defined procedure, the six to eight percent concentration will yield a 20 to 27 drop range. Fewer drops indicate a low concentration of supplemental coolant additive and more drops indicate a high concentration. Adjust the concentration appropriately.

If the supplemental coolant additive concentration is greater than the maximum of eight percent: drain some of the coolant, refill the system with acceptable water, and retest the concentration level.

### Conventional Cooling System Maintenance

Check the antifreeze solution frequently in cold weather to ensure adequate freeze protection. Test the concentration or submit a coolant sample to your Caterpillar dealer in order to monitor the supplemental coolant additive concentration in your engine's coolant mixture every 250 service hours or monthly, whichever comes first. Supplemental coolant additive or a maintenance additive element (if equipped) may be needed every 250 service hours or monthly, whichever come first.

---

#### NOTICE

To prevent over-inhibiting the engine's cooling system, do not use both supplemental coolant additive liquid and a supplemental coolant additive element (if equipped) at the same time. Use one method exclusively.

---

When using Diesel Engine Antifreeze/Coolant and supplemental coolant additive, the cooling system should be drained, cleaned, flushed, and filled with new coolant every 3000 service hours or every two years, whichever come first. Refer to the topic Maintenance Intervals in this manual.

When NOT using Caterpillar Diesel Engine Antifreeze/Coolant and supplemental coolant additive, the drain/flush procedure must be performed at least every year.

After you drain and you refill the cooling system, operate the engine with the radiator filler cap removed until the coolant reaches normal operating temperature and the coolant level stabilizes. Add coolant mixture as necessary to fill the system to the proper level.

### Cooling System Cleaning

Draining, cleaning, and flushing the cooling system removes small particles, undesirable chemicals, scale, and other deposit formations. Not performing maintenance on the cooling system can eventually cause engine overheating problems that could result in severe damage to engine and components.

Clean the cooling system if the system becomes contaminated, if the engine overheats, or if foaming is observed.

Caterpillar's Fast Acting Cooling System Cleaner is designed to clean the system of harmful scale and corrosion. The cleaner dissolves mineral scale, corrosion products, light oil contamination, and sludge.

Fast Acting Cooling System Cleaner is available from your Caterpillar dealer in the quantities listed. Follow the product label directions for proper use.

| CATERPILLAR COOLING SYSTEM<br>FAST ACTING CLEANER |                         |
|---|-------------------------|
| Part No.  | Size                    |
| 4C-4609   | 0.47 L (1 pt)           |
| 4C-4610   | 0.95 L (1 qt)           |
| 4C-4611   | 3.8 L (1 US gal)        |
| 4C-4612   | 19 L (5 US Gallons)     |
| 4C-4613   | 208.5 L (55 US Gallons) |



# Fuel Specifications

## Fuel Recommendations

### NOTICE

Fill the fuel tank at the end of each day of operation to remove moist air and prevent condensation. Maintain a constant level in the tank (near the top) to avoid drawing moisture into the tank as the level decreases.

Do not fill the tank to the top. Fuel expands as it warms, and may overflow.

Do not fill fuel filters with fuel before installing them. Contaminated fuel causes accelerated wear to fuel system parts.

Use only fuel recommended in this section of this manual. Fuel grades recommended for use in Caterpillar diesel engines are: No.2-D diesel fuel with low sulfur (0.05 percent maximum), or regular sulfur (0.5 percent maximum). No.1 grades are acceptable.

The table lists worldwide fuel standards which meet Caterpillar requirements.

| WORLDWIDE FUEL SPECIFICATIONS—DIESEL ENGINES |   |
|--|---|
| Specifications                               | Fuel Designation  |
| U.S. STANDARDS<br>ASTM D975                  | No. 1-D, No. 2-D & No. 4 Diesel Fuel                            |
| ASTM D396                                    | Low Sulfur No. 1 & No. 2 Diesel Fuel                            |
| ASTM D2880                                   | No. 1-GT & No. 2-GT Gas Turbine Fuels                           |
| BRITISH STANDARDS<br>BS 2869                 | Classes A1, A2 & B1 Engine Fuels<br>Classes C2 & D Burner Fuels |
| GERMAN STANDARDS<br>DIN 51601                | Diesel Fuel   |
| DIN 51603                                    | Heating Oil EI  |
| AUSTRALIAN STANDARD<br>AS 3570               | Automotive Diesel Fuel  |
| JAPANESE STANDARD<br>JIS K2204               | Types 1 (spl), 1, 2, 3 & 3 (spl) Gas Oil                        |
| U.S. GOVERNMENT<br>VV-F-800C                 | DF-1, DF-2 & DF-20 Con. U.S. Diesel Fuel                        |
| VV-F-815C                                    | FS-1 & FS 2 Burner Fuel Oil                                     |
| U.S. MILITARY<br>MIL-F-16884G                | Marine Oil  |

Aviation kerosene-type fuels meeting acceptable limits may also be used as an engine fuel. The table lists some of the acceptable kerosene-type fuels.

| ACCEPTABLE KEROSENE-TYPE FUELS |   |
|--------------------------------|---|
| Standard                       | Description                                       |
| ASTM D 1655-80                 | Aviation Turbine Fuel (JET A-1)                   |
| MIL-T-5624L                    | Aviation Turbine Fuel (JP-5) (NATO Code No. F-44) |
| MIL-T-83133B                   | Aviation Turbine Fuel (JP-8) (NATO Code No. F-34) |
| VV-F-800F1                     | Grade DF-A (Arctic)                               |

A minimum viscosity of 1.4 cSt at 38°C (100°F) is required to properly lubricate Caterpillar fuel system components. Kerosene-type fuels have a lower viscosity for low temperature operation.

## Maintenance Section Fuel Specifications

The kerosene-type fuels have less energy per unit volume than diesel fuels, producing less peak power. More kerosene-type fuel is needed than diesel fuel to do the same amount of work.

Caterpillar diesel engines are capable of burning a wide range of distillate fuels. Burning clean, stable blends of distillate fuel meeting the listed requirements will provide quality engine service life.

| <b>DISTILLATE FUEL RECOMMENDATIONS - DIESEL ENGINES</b> |   |
|---|---|
| <b>Specifications</b>                                   | <b>Requirements<sup>1</sup></b>               |
| Aromatics (ASTM D1319)                                  | 35% Max.                                      |
| Ash (ASTM D482)   | 0.02% Weight Max.                             |
| Cetane Number (ASTM D613)                               | 40 Minimum                                    |
| Cloud Point (ASTM D97)                                  | Not Above Lowest Expected Ambient Temperature |
| Gravity API (ASTM D287)                                 | 30 Min. and 45 Max.                           |
| Pour Point (ASTM D97)                                   | 6°C (10°F) Below Ambient Minimum              |
| Sulfur (ASTM D2788, D3605 or D1552)                     | 0.5% Max.<br>(See Sulfur Topic)               |
| Viscosity, Kinematic @ 38°C (100°F) (ASTM D445)         | 20.0 cSt Max.<br>1.4 cSt Min.                 |
| Water & Sediment (ASTM D1796)                           | 0.01% Max.                                    |

<sup>1</sup> As delivered to fuel system

NOTE: When economics or fuel availability dictate, other fuel types may be burned in the engine. Consult your Caterpillar dealer for more information and advice on any specific fuel.

### Cetane Number

During average starting conditions, direct injection engines require a minimum cetane number of 40. A higher cetane value may be required for high altitude or cold weather operation.

### Filterability

Clean fuels should have no more than 0.1 percent of sediment and water. Fuel stored for extended periods of time may oxidize and form solids, causing filtering problems.

### Pour Point

Fuel pour point should be at least 6°C (10°F) below the lowest ambient temperature at which the engines must start and operate. Lower pour points of No.1 or No.1-D fuel may be necessary in extremely cold weather.

### Cloud Point

The cloud point should be below the lowest ambient temperature at which the engines must start and operate, in order to prevent the fuel filter elements from plugging with wax crystals. Refer to the topic Fuel Problems in Cold Weather Recommendations, SEBU5898, for additional information.

### Viscosity

Fuel viscosity affects the lubrication of fuel system components and fuel atomization. The provided viscosity limits address both of those affects.

### Additives

Fuel additives are generally not recommended or needed for the specified fuels listed. Cetane improvers can be used as necessary for direct injection engine requirements. Biocides may be needed to eliminate microorganism growth in storage tanks. In cold weather conditions, treatment for entrained water may also be necessary.

Consult your fuel supplier about the use of additives to prevent incompatibility among additives already in the fuel and the additives to be used.

### Fuel Sulfur

The percentage of sulfur in fuel affects engine oil recommendations. Fuel sulfur can change chemically during combustion. The chemical change forms both sulfurous acids and sulfuric acids. The acids contact metal surfaces and cause corrosive wear to the surfaces. Sulfur oxides formed during combustion also produce particulate exhaust emissions.

Some lubricating oil additives contain alkaline compounds which neutralize acids in combustion gases and minimize corrosive wear. Reserve alkalinity in lubricating oil is measured and defined with a Total Base Number (TBN).

Periodically request fuel sulfur content information from your fuel supplier. Fuel sulfur content can change with each bulk delivery.

More information concerning fuel sulfur and lubrication can be found in the topic Lubricant Specifications in this manual.

Refer to Diesel Fuels and Your Engine, SEBD0717, or contact your Caterpillar dealer for more information on fuel selection and fuel properties.

## Scheduled Oil Sampling (S•O•S)

Caterpillar recommends using Scheduled Oil Sampling (S•O•S), at regularly scheduled intervals, to complement a good preventive maintenance program.

The Caterpillar Scheduled Oil Sampling Program, (S•O•S), was developed to help Caterpillar users realize the highest possible value from their equipment by minimizing repair costs and maximizing availability. The S•O•S program is a series of diagnostic tests which analyze used lubricating oils from the oil wetted compartments of the equipment. By analyzing the used oils, problems may be identified early, before extensive component failure occurs. This reduces repair cost and downtime.

The S•O•S program is coupled with a wide range of repair options so that when a problem is identified, an appropriate matched repair plan is available. This offers the user a more complete service to minimize repair costs and schedule down-time. S•O•S can also measure the effectiveness of the user's maintenance program.

### Obtain S•O•S Sample

There are several methods used to obtain S•O•S samples.

NOTE: Sampling methods recommended are in preference order. If one of the first two methods is not feasible, then use the drain stream method.

- Use an in-line sampling valve.
- Use a sampling gun inserted into the sump.
- Use the drain stream method when changing oil.

When using the drain stream method to obtain an oil sample, take the sample after some oil has drained out and before the final drain oil. The oil at the beginning or end of the drain stream is not mixed well enough to be representative of circulating oil in the compartment and may carry debris that can give false S•O•S analysis results.

### S•O•S Analysis

S•O•S is composed of three basic tests:

- Wear Analysis
- Chemical and Physical Tests
- Oil Condition Analysis

Wear Analysis monitors the components wear rates by measuring wear elements and contaminants found in the used oil. Through monitoring the used oil, normal component wear trends are determined. Many failures can be identified when wear trends and/or contaminants significantly exceed past trends.

Detectable failures are those caused by component wear and gradual dirt contamination. Wear analysis is not able to predict failures due to component fatigue, sudden loss of lubrication, or sudden ingestion of a large amount of dirt since failures of this nature occur too rapidly.

Chemical and Physical Tests are used to determine whether the used oil has been contaminated with water, fuel or antifreeze and if these contaminants exceed maximum limits.

Oil Condition Analysis determines the degree of deterioration of the used oil by measuring the amount of sulfur products, oxidation, nitration and soot present in the used oil. It also can monitor additive depletion and detect ethylene glycol and butyl cellosolve contamination.

Oil Condition Analysis can help regulate (reduce, maintain or extend), oil change intervals for a specific machine/engine in a given application. Oil Condition Analysis must always be used with Wear Analysis and the Chemical and Physical Tests.

| S•O•S INTERVAL CHART |           |
|----------------------|-----------|
| Compartment          | Interval  |
| Engine Oil           | 250 Hours |
| Marine Gear Oil      | 250 Hours |
| Transmission Oil     | 500 Hours |
| Hydraulic Oil        | 500 Hours |
| Final Drive Oil      | 500 Hours |

Consult your Caterpillar dealer for complete information and assistance in establishing a Scheduled Oil Sampling Program for your equipment.

# Lubricant Specifications

## General Information

Caterpillar recognizes and supports the American Petroleum Institute (API) "Engine Oil Licensing and Certification System" for engine oils. The API publication No. 1509, 13th edition, contains the detailed information concerning this system. Engine oils bearing the API symbol are licensed by the API.

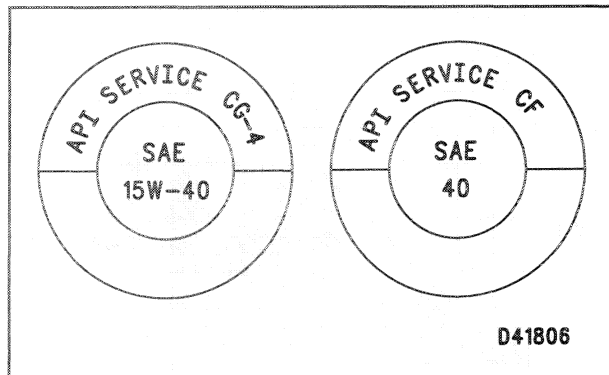

Examples of the API symbol.

Diesel engine oil classifications CD, CD-2 and CE will not be API licensed categories after January 1, 1996. Caterpillar will only reference those categories that are licensed by the API. The table summarizes the status of the categories.

| OIL CLASSIFICATION STATUS |                   |
|---------------------------|-------------------|
| Obsolete                  | Current           |
| CC, CD                    | CF                |
| CD-2 <sup>1</sup>         | CF-2 <sup>1</sup> |
| CE                        | CF-4, CG-4        |

## Engine Lubricant Specifications

### Caterpillar Oil

Caterpillar oils have been developed, tested, and approved by Caterpillar to provide the performance and life that has been designed and built into Caterpillar diesel engines. Caterpillar oils are used for engine development and factory fill. Caterpillar oils are available from Caterpillar dealers. Due to significant variations in the quality and performance of commercially available oils, Caterpillar recommends the following oils:

### Caterpillar Diesel Engine Oil (DEO) (multi-grade)

Caterpillar DEO multi-grade oils are formulated with detergents, dispersants, and sufficient alkalinity to provide superior performance in Caterpillar diesel engines. DEO multi-grade oils are blended in two viscosity grades: SAE 10W-30 and SAE 15W-40. Refer to the lubricant viscosity chart to choose the correct viscosity grade based on ambient temperatures. Multi-grade oils provide the correct viscosity for a broad range of operating temperatures and for cold engine starts. Multi-grade oils are also effective in maintaining low oil consumption and low levels of piston deposits.

Caterpillar DEO multi-grade oils are also qualified for use in other diesel engines and in gasoline engines. Consult the engine manufacturer's guide for the recommended specifications, and compare to the specifications of Caterpillar DEO multi-grade. The current Caterpillar DEO industry specifications are listed on the label and on the product data sheets.

### Commercial Diesel Engine Oils

The performance of commercial diesel engine oils are based on API categories. These API categories are developed to provide commercial lubricants for a wide variety of diesel engines that operate at various conditions.

If Caterpillar DEO (multi-grade) is not used, only use the following commercial oils:

- Preferred – API CG-4
- Allowed – API CF-4

API CG-4 oils are preferred for use in Caterpillar engines because of the fuel sulfur level. API CG-4 is the only oil category that evaluates oils with engine tests utilizing 0.05 percent sulfur fuel.

The following explanations of these API categories can be used to make the proper choice of a commercial oil.

**CG-4** – CG-4 is the newest oil category. CG-4 oils were primarily developed for diesel engines that are operating with 0.05 percent sulfur diesel fuel. All of the laboratory engine tests for this category were performed with 0.05 percent sulfur diesel fuel. CG-4 also defines oils that have superior soot dispersancy. CG-4 oils will provide improved viscosity control and improved crankcase cleanliness in applications where oil soot is a problem. CG-4 oils should also be used in engines that contain hydraulically actuated fuel injection pumps; these are the first oils to pass industry tests for foam control and viscosity shear loss. CG-4 oils must also pass recently developed tests for metals corrosion, and wear. CG-4 oils can be used in all Caterpillar engines where CF-4 oils are recommended.

**CF-4** – CF-4 oils service a wide variety of modern diesel engines. This oil classification was developed with 0.40 percent sulfur diesel fuel. The fuel used in the CF-4 tests represents the type of diesel fuels commonly available world wide. CF-4 oils provide improved piston deposit control and improved oil control when compared to the CE category oils. CF-4 oils also provide improved soot dispersancy compared to CD or CF category oils.

Some commercial oils meeting these API specifications may require shortened oil change intervals as determined by close monitoring of oil condition and wear metals. The Caterpillar S•O•S Analysis Program is the preferred testing method.

Consult your Caterpillar dealer for the latest oil recommendations.

---

**NOTICE**

Failure to follow these oil recommendations can cause shortened engine life due to deposits and/or excessive wear.

---

## Total Base Number (TBN) and Fuel Sulfur Levels For Caterpillar Diesel Engines

### Caterpillar Prechamber Combustion Engines

The TBN for a new oil is dependent on the sulfur level of the fuel used. For precombustion chamber (PC) engines running on distillate fuel, the minimum new oil TBN (by ASTM D2896) must be 20 times the fuel sulfur level. The minimum TBN of new oil is 5, regardless of low fuel sulfur level. See the illustration.

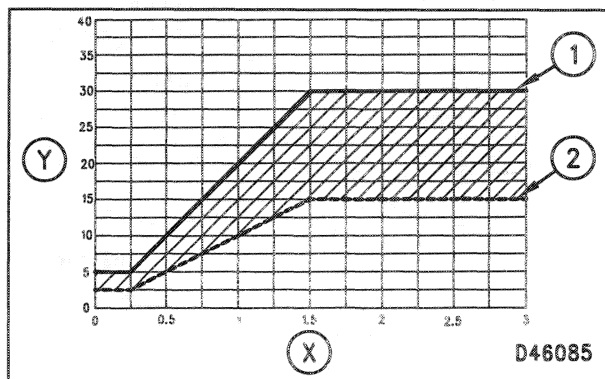

Oil TBN shown by ASTM D2896 (Y). Percent of fuel sulfur by weight (X). New oil TBN (1). Change oil when the used oil TBN limit (2) is reached.

Caterpillar's 20 times rule for TBN (Reference: Oil and Your Engine, SEBD0640) versus fuel sulfur was a general requirement developed in the early 1980's for Caterpillar prechamber combustion (PC) system engines. Caterpillar still maintains 20 times TBN value for PC engines. Engines built prior to 1990 can continue to use single grade viscosity oil or commercial oils, provided the engine operates satisfactorily.

Fuel sulfur neutralization of new oil formulations in direct injection (DI) system engines is more effective. Field results indicate that direct injection (DI) combustion systems and the oils now recommended for those engines will operate at an oil TBN equal to ten times the fuel sulfur.

### Caterpillar Direct Injection Diesel Engines

For direct injection engines running on distillate diesel fuel, the minimum new oil TBN (by ASTM D 2896) must be 10 times the fuel sulfur level, and the minimum TBN is 5 regardless of low fuel sulfur level. See the illustration.

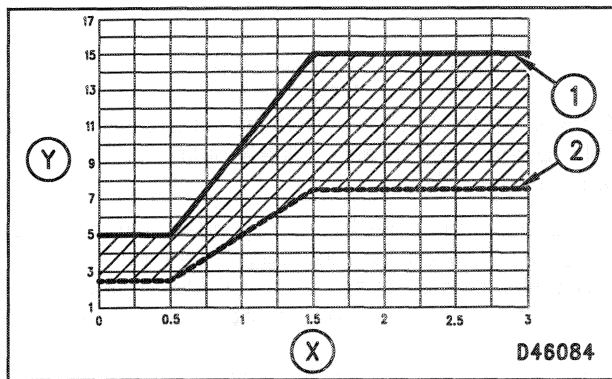

Oil TBN shown by ASTM D2896 (Y). Percent of fuel sulfur by weight (X). New oil TBN (1). Change oil when the used oil TBN limit (2) is reached.

In areas where the fuel sulfur exceeds 1.5 percent, choose an oil with the highest TBN that is within the API CF-4 or CG-4 categories, and shorten the oil change period based on oil analysis. The oil analysis should evaluate oil condition and wear metals. High TBN oils that are not within the API CF-4 or CG-4 categories can produce excessive piston deposits leading to a loss of oil control and bore polishing.

#### NOTICE

Operation at fuel sulfur levels over 1.5 percent may require shortened oil change periods to maintain adequate wear protection.

### Engine Lubricant Viscosity Recommendations

The proper SAE viscosity grade oil is determined by the minimum outside temperature at cold engine start-up, and the maximum outside temperature during engine operation. Use the minimum temperature column in the lubricant viscosities chart to determine the oil viscosity required for starting a "cold soaked" engine. Use the maximum temperature column in the lubricant viscosities chart to select the viscosity for operation at the highest temperature anticipated. In general, use the highest viscosity oil available that still meets the start-up temperature requirements.

| ENGINE OIL VISCOSITY PROTECTION |                     |                 |
|---------------------------------|---------------------|-----------------|
| Engine Oil Viscosity Grade      | Ambient Temperature |                 |
|                                 | Minimum °C (°F)     | Maximum °C (°F) |
| SAE 0W20                        | -40° (-40°)         | 10° (50°)       |
| SAE 5W30                        | -30° (-22°)         | 30° (86°)       |
| SAE5W40                         | -30° (-22°)         | 40° (104°)      |
| SAE 10W30                       | -20° (-4°)          | 40° (104°)      |
| SAE 15W40                       | -15° (5°)           | 50° (122°)      |

### Synthetic Base Stock Oils

Synthetic base stock oils are acceptable for use in Caterpillar engines and machines if these oils meet the performance requirements specified by Caterpillar for a particular compartment.

Synthetic base stock oils generally outperform non-synthetics in two areas:

- Improved low temperature viscosity characteristics, especially in Arctic conditions
- Improved oxidation stability, especially at high operating temperatures

Some synthetic base stock oils have performance characteristics that enhance the service life of the oil. However, Caterpillar does NOT recommend the automatic extension of oil drain intervals for any oil, including synthetic base stock oils. For Caterpillar diesel engines, oil drain intervals can only be adjusted through an oil analysis program that contains the following elements: oil condition and wear metals (Caterpillar S•O•S Oil Analysis preferred), trend analysis, fuel consumption, and oil consumption.

### Re-Refined Base Stock Oils

Re-refined base stock oils are acceptable for use in Caterpillar engines and machines if these oils meet the performance requirements specified by Caterpillar for a particular compartment. Re-refined oils can be used exclusively in a finished oil or in combination with new base stocks. The US Military and other heavy equipment manufacturers have also accepted the use of re-refined base stock oils with the same criteria.

The re-refining process should be adequate to remove all wear metals and oil additives that were present in the used oil. This type of re-refining is generally accomplished by vacuum distillation and hydrotreating the used oil. Filtering alone is inadequate for producing a high quality re-refined base stock from used oil.

### After-Market Oil Additives

Caterpillar does NOT recommend the use of after-market oil additives. After-market oil additives are not necessary to achieve life predictions or to achieve rated performance. Fully formulated finished oils are made up of base stocks and commercial additive packages. These additive packages are blended into the base stocks at precise percentages to provide finished oils with performance characteristics that meet lubricant industry standards.

Lubricant industry standard tests do not exist to evaluate the performance of after-market oil additives. There are also no lubricant industry standard tests to evaluate the compatibility of these after-market additives in a finished oil. After-market additives could be incompatible with the finished oil additive package, and lower the performance of the finished oil. The after-market additive could fail to mix with the finished oil, and produce a sludge in the crankcase. Caterpillar discourages the use of after-market additives in finished oils.

To achieve all the performance that was built into a Caterpillar engine, follow these guidelines:

- Select the proper Caterpillar oil or commercial oil that meets the compartment specifications.
- Select the proper oil viscosity based on the Engine Oil Viscosity Chart in this manual.
- Service the engine at the specified interval with new oil and oil filter.
- Perform maintenance at the intervals specified in this manual.

### Caterpillar Transmission/Drive Train Oil (TDTO)(TO-4)

Caterpillar TDTO TO-4 is balanced to give maximum frictional material life in power shift transmissions. TO-4 oil specifications include frictional and gear wear requirements. TO-4 oil is offered in several viscosity grades, including SAE 50, for maximum component life at high ambient temperatures and heavy duty cycles.

---

#### NOTICE

TO-4 is formulated for transmissions and drive trains only. Using TO-4 in an engine would result in shortened engine life.

Do not use engine oils for lubricating transmissions or drive trains. Failure to follow this recommendation can cause shortened transmission life due to material incompatibility and inadequate frictional requirements for disk materials.

---

Caterpillar does not currently offer multi-grade oils for use in transmissions. Multi-grade oils which use high molecular weight polymers as viscosity index improvers lose their viscosity effectiveness (permanent and temporary shear), and are therefore not recommended for transmission and drive train compartments. The Caterpillar TO-4 specification includes a test for multi-grade oil shear stability: oils that meet this specification may be available in the future.

### Transmission Lubricant Viscosity Recommendation

The following table lists TDTO viscosity grades, quantities, and corresponding part numbers available from your Caterpillar dealer.

| CATERPILLAR TRANSMISSION/DRIVE TRAIN OIL |                    |                        |
|--|--------------------|------------------------|
| Caterpillar TDTO                         | 19 L<br>(5 US gal) | 208.5 L<br>(55 US gal) |
| SAE 10W                                  | 8T-9568            | 8T-9569                |
| SAE 30                                   | 8T-9572            | 8T-9573                |
| SAE 50                                   | 8T-9576            | 8T-9577                |



## Caterpillar Lubricating Grease

The National Lubricating Grease Institute (NLGI) classifies grease, based on ASTM D217-68 Worked Penetration characteristics. Grease characteristics are given a defined consistency number.

Caterpillar has grease and lubricants for all applications. Your Caterpillar dealer can provide you with complete information regarding the different types and sizes of Caterpillar lubrication and special application products.

| CATERPILLAR LUBRICATING GREASE |   |                 |
|--------------------------------|---|-----------------|
| Part No.                       | Item  | Size            |
| 2S-3230                        | Bearing Lubricant <sup>1</sup>                    | 411 g (14.5 oz) |
| 5P-0960                        | Molybdenum Grease <sup>2</sup>                    | 411 g (14.5 oz) |
| 1P-0808                        | All-Purpose Lubricant <sup>3</sup>                | 411 g (14.5 oz) |
| 2S-3230<br>2S-3230             | Water & Temperature Resistant Grease <sup>4</sup> | 454 g (16 oz)   |

<sup>1</sup> NLGI No. 2 Grade, services heavily loaded ball and roller bearings operating at high speeds, extreme pressure, and temperatures from -34 to 163°C (-18 to 300°F). Use for bearings in electric motors, fan drives, starting motors, alternators/generators and to pack similar bearings in many other applications.

<sup>2</sup> NLGI No. 2 Grade, three to five percent molybdenum disulfide, multi-purpose grease with an operating temperature range from -28 to 149°C (-18 to 300°F).

<sup>3</sup> NLGI No. 2 Grade lithium grease has mechanical stability, resists oxidation, protects from rust, excellent breakaway torque. For light-duty automotive-type applications and temperatures up to 175°C (350°F).

<sup>4</sup> This NLGI No 2 Grade has exceptional water resistance, meets ASTM D-1264 Water Washout Test. This low and high temperature resistant grease has a starting torque at -40°C (-40°F), and is still not fluid at 316°C (600°F).

## Caterpillar Specialty Lubricants

| CATERPILLAR SPECIALTY LUBRICANTS |  |                 |
|----------------------------------|--|-----------------|
| Part No.                         | Item                                     | Size            |
| 6V-4876                          | Molykote Paste Lubricant <sup>1</sup>    | 500 g (17.6 oz) |
| 5P-3931                          | High Temperature Anti-Seize <sup>2</sup> | 411 g (14.5 oz) |

<sup>1</sup> Recommended for typical uses such as on head bolt threads and washers.

<sup>2</sup> Recommended for connectors such as exhaust manifold studs and nuts.

## Hydraulic Oil

### Cat Hydraulic Oil (HYDO)

Cat Hydraulic Oil is formulated with a balanced additive system, including detergents, rust inhibitors, antiwear agents and defoamers. It will offer maximum protection against mechanical wear, rusting and corrosive wear in all hydraulic and hydrostatic transmission systems.

Cat Hydraulic Oil should be used to achieve maximum life and performance from hydraulic system components and hydrostatic transmissions. Use of Cat Hydraulic Oil is recommended in most hydraulic and hydrostatic systems.

If higher viscosities are required because of high ambient temperatures, the following Caterpillar oils can be used:

- Cat Diesel Engine Oil DEO (CF-4/CG-4)
- Cat Transmission/Drive Train Oil (TDTO)

### Commercial Oils

If Cat oils cannot be used, the following commercial classifications can be used in the hydraulic system:

- API CF-4/SG
- MIL-L-2104E

Premium industrial hydraulic oils that have passed the Vickers vane pump test (35VQ25) and/or have a minimum of 0.09% zinc additive may also be used. These oils should have antiwear, antifoam, antirust and antioxidation additives for heavy duty use as stated by the oil supplier. ISO viscosity grade of 46 would normally be selected.

## **Gear Oil (GO)**

### **Cat Gear Oil (GO)**

Cat Gear Oil offers maximum protection against the scoring and pitting of gear teeth and rolling element bearings.

Cat Gear Oil can also provide excellent stability under high temperature conditions and has superior low temperature performance. It will also give protection against rust and corrosion.

For those components needing oils with extreme pressure (EP) additives in severe boundary lubrication, the gear type oils provide this extra protection. The EP additive is deposited as a solid film lubricant in heavily loaded gear and bearing areas for added protection.

### **Commercial Oils**

If Cat Gear Oil cannot be used, select an oil that meets:

- API GL-5 specification oil
- MIL-L-2105C specification oil

# Lubricant Viscosities and Refill Capacities

## Lubricant Viscosities

| LUBRICANT VISCOSITIES <sup>1</sup><br>FOR AMBIENT (OUTSIDE) TEMPERATURES |                           |     |     |     |      |
|--|---------------------------|-----|-----|-----|------|
| Compartment<br>or System   | Oil<br>Viscosities        | °C  |     | °F  |      |
|  |                           | Min | Max | Min | Max  |
| Engine<br>Crankcase  | SAE 0W20                  | -40 | +10 | -40 | +50  |
|  | SAE 5W30                  | -30 | +30 | -22 | +86  |
|  | SAE 5W40                  | -30 | +40 | -22 | +104 |
|  | SAE 10W30                 | -20 | +40 | -4  | +104 |
|  | SAE 15W40                 | -15 | +50 | +5  | +122 |
| Transmission<br>TDTO   | SPC SAE 5W20 <sup>2</sup> | -30 | +10 | -22 | +50  |
|  | SAE 10W                   | -20 | +10 | -4  | +50  |
|  | SAE 30                    | 0   | +35 | +32 | +95  |
|  | SAE 40                    | +5  | +45 | +41 | +113 |
|  | SAE 50                    | +10 | +50 | +50 | +122 |
| Hydraulic<br>System<br>HYDO  | SPC SAE 5W20 <sup>2</sup> | -30 | +40 | -22 | +104 |
|  | SAE 5W20                  | -25 | +10 | -13 | +50  |
|  | SAE 10W                   | -20 | +40 | -4  | +104 |
|  | SAE 10W30                 | -20 | +40 | -4  | +104 |
|  | SAE 15W40                 | -15 | +50 | +5  | +122 |
|  | SAE 30                    | +10 | +50 | +50 | +122 |
| Differentials and<br>Final Drives<br>TDTO                                | SPC SAE 5W20 <sup>2</sup> | -30 | 0   | -22 | +32  |
|  | SAE 10W                   | -30 | 0   | -22 | +32  |
|  | SAE 30                    | -20 | +25 | -4  | +77  |
|  | SAE 40                    | -10 | +40 | +14 | +104 |
|  | SAE 50                    | -15 | +50 | +5  | +122 |

<sup>1</sup> When operating below -20°C (-4°F) refer to the Operation and Maintenance Manual, for Cold Weather Recommendations, form SEBU5898, available from your Caterpillar dealer.

<sup>2</sup> Special oils with synthetic base stocks that do not contain polymer viscosity index improvers. The high viscosity index of the "synthetic" oils provide natural multiviscosity properties.

| REFILL CAPACITIES - (APPROXIMATE) |        |              |                  |
|-----------------------------------|--------|--------------|------------------|
| Compartment<br>or System          | Liters | U.S.<br>Gal. | Imperial<br>Gal. |
| Cooling System                    | 43.3   | 11.2         | 9.5              |
| Fuel Tank (814F)                  | 464    | 120.6        | 102              |
| Fuel Tank (815F) (816F)           | 446    | 116          | 98.1             |
| Engine Oil                        | 28     | 7.28         | 6.16             |
| Transmission Oil                  | 59     | 15.3         | 13               |
| Front Differential                | 47     | 12.2         | 10.3             |
| Rear Differential                 | 47     | 12.2         | 10.3             |
| Hydraulic Tank Oil                | 87     | 22.6         | 19.1             |

## Maintenance Intervals

### When Required

|  |    |
|--|----|
| Engine Air Intake System – Clean/service filters | 85 |
| Ether Starting Aid – Replace empty cylinders     | 87 |
| Fuses – Replace                                  | 88 |
| Windshield Wipers and Washer – Inspect           | 90 |
| Cutting Edge and End Bits – Change               | 91 |
| Tamping Tips (815F) – Inspect/replace            | 92 |
| Cleaner Bar (815F) – Inspect/replace             | 92 |
| Chopper Blades (816F) – Inspect/replace          | 94 |
| Filter Inspection – Inspect                      | 94 |

### Every 10 Service Hours or Daily

|  |     |
|--|-----|
| Engine Oil – Check the oil level         | 95  |
| Transmission Oil – Check the oil level   | 96  |
| Hydraulic Oil – Check the oil level      | 96  |
| Cooling System – Check coolant level     | 97  |
| Fuel Tank – Drain water and sediment     | 98  |
| Walk-Around Inspection – Inspect machine | 99  |
| Seat Belt – Inspect                      | 101 |
| Brakes, Indicators and Gauges – Test     | 101 |
| Back-up Alarm – Test                     | 102 |

### Every 50 Service Hours or Weekly\*

|                                |     |
|--------------------------------|-----|
| Cab Air System – Clean filters | 103 |
|--------------------------------|-----|

### Every 100 Service Hours or 2 Weeks\*

|  |     |
|--|-----|
| Rear Axle Trunnion – Lubricate 2 fittings                  | 104 |
| Steering Cylinder Bearings – Lubricate 4 fittings          | 104 |
| Bulldozer Stabilizer – Lubricate 1 fitting                 | 105 |
| Bulldozer Cylinder Trunnion Bearing – Lubricate 2 fittings | 106 |
| Bulldozer Cylinder Rod Bearing – Lubricate 1 fitting       | 106 |

### Every 250 Service Hours or Monthly\*

|   |     |
|---|-----|
| Engine Oil and Filter – Change oil and filter. If sulfur content in the fuel is greater than 1.5% by weight, use an oil with a TBN of 30 and reduce oil change interval by one half | 107 |
| Engine Crankcase Breathers – Clean  | 108 |
| Engine Valve Lash – Adjust on new or reconditioned engines at first oil change only   | 128 |
| Cooling System (Conventional Antifreeze) – Add coolant additive. This maintenance procedure is for machines using conventional antifreeze only                                      | 108 |
| Brakes – Test   | 109 |

|   |     |
|---|-----|
| Drive Shaft Spline – Lubricate fitting    | 111 |
| Fan Bearing – Lubricate                   | 111 |
| Air Conditioner – Test/adjust             | 112 |
| Fan and Alternator Belts – Inspect/adjust | 113 |
| Batteries – Check                         | 114 |

### Every 500 Service Hours or 3 Months\*

|   |     |
|---|-----|
| Transmission – Change filter            | 116 |
| Hydraulic System – Service elements/cap | 117 |
| Fuel System – Clean/change filters      | 118 |
| Fuel Tank Cap and Fill Screen – Clean   | 120 |

### Every 1000 Service Hours or 6 Months\*

|   |     |
|---|-----|
| Transmission Oil – Change oil                       | 122 |
| Drive Shaft Universal Joints – Lubricate 5 fittings | 123 |
| Drive Shaft Support Bearing – Lubricate fitting     | 124 |
| Frame Pivot Bearings – Lubricate 2 fittings         | 124 |
| Rollover Protective Structure (ROPS) – Inspect      | 125 |

### Every 2000 Service Hours or 1 Year\*

|                                     |     |
|-------------------------------------|-----|
| Hydraulic Oil Tank – Change the oil | 126 |
| Differentials – Change the oil      | 127 |
| Engine Valve Lash – Adjust          | 128 |
| Engine Valve Rotators – Inspect     | 128 |
| Wet Disk Brakes – Inspect           | 129 |

### Every 3000 Service Hours or 2 Years \*

|  |     |
|--|-----|
| Cooling System Coolant (Conventional Antifreeze) – Clean/Flush/Change coolant and replace thermostat for machines using conventional antifreeze only | 130 |
| Cooling System Coolant (Extended Life Coolant) – add "Extender". This maintenance procedure is for machines using Extended Life Coolant only         | 131 |

### Every 6000 Service Hours or 4 Years \*

|  |     |
|--|-----|
| Cooling System Coolant (Extended Life Coolant) – Clean/Flush/Change coolant on machines using Extended Life Coolant only | 132 |
|--|-----|

\*First Perform Previous Service Hours Items

## When Required

You must read and understand the warnings and instructions contained in the Safety section of this manual, before performing any operation or maintenance procedures.

### Engine Air Intake System

#### Clean the Air Intake

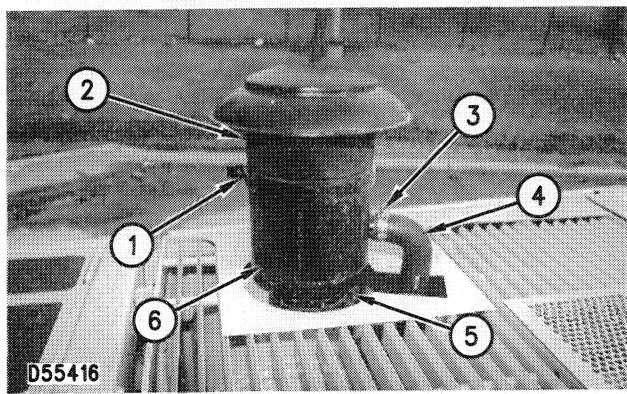

1. Loosen bolt on clamp (1) and remove hood assembly (2).
2. Inspect the screen for accumulation of dirt and debris.
3. Loosen hose clamp (3) and remove hose (4) from the hood assembly.
4. Loosen clamp (5) and remove body assembly (6).
5. Clean all parts with compressed air or wash in warm water. Dry all parts.
6. Install body assembly (6) and tighten clamp (5). Torque the bolt to  $24 \pm 7 \text{ N}\cdot\text{m}$  ( $18 \pm 5 \text{ lb ft}$ ).
7. Install hose (4) and tighten clamp (3).
8. Install hood assembly (2) and tighten bolt (1).

#### Service the Filter Elements

##### NOTICE

Service the air cleaner only with the engine stopped. Engine damage could result.

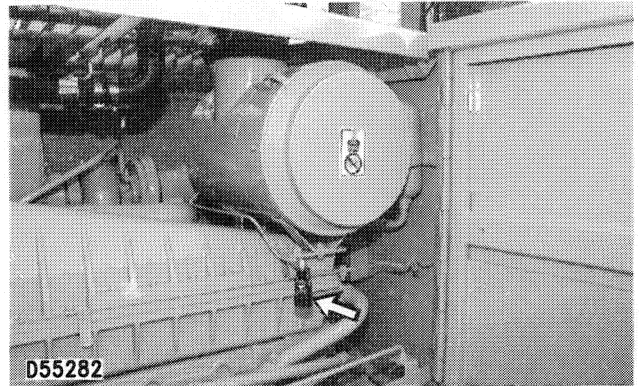

Service the air cleaner if the yellow piston in the filter element indicator moves into the red zone with the engine running at high idle. Stop the engine.

#### Service the Primary Element



1. Open the engine access door on the right side of the machine.

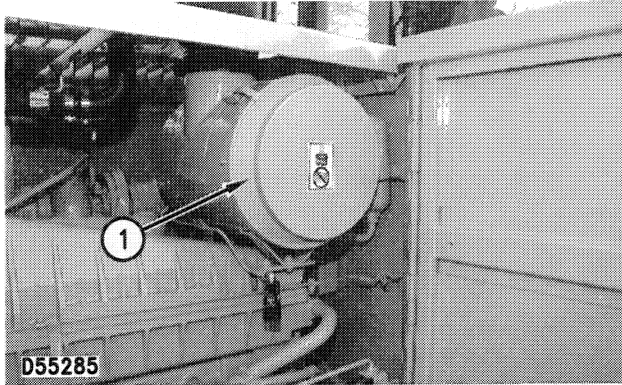

2. Remove the air cleaner cover (1).

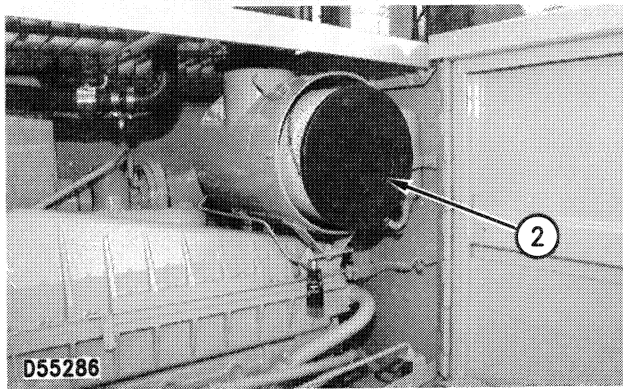

3. Remove the primary filter element (2) from the air cleaner housing.

4. Clean the inside of the air cleaner housing.

5. Clean and inspect the primary element. See Cleaning Primary Elements.

6. Install a clean primary element.

7. Clean and install the cover.

8. Reset the filter element indicator.

9. Close the access door.

If the yellow piston in the filter element indicator moves into the red zone after starting the engine, or the exhaust smoke is still black after installation of a clean primary filter element, install a new primary filter element. If the piston remains in the red zone after reset and installing a new primary filter element, replace the secondary element.

The primary element should be replaced after being cleaned a maximum of six times. Replace the element once a year even though it has not been cleaned six times.

### Change the Secondary Element

#### NOTICE

Always replace the secondary filter element. Never attempt to reuse it by cleaning.

The secondary filter element should be replaced at the time the primary element is serviced for the third time.

The secondary filter element should also be replaced if the yellow piston in the filter element indicator enters the red zone after installation of a clean primary element, or if the exhaust smoke is still black.

1. Open the access cover.

2. Remove the housing cover and the primary element.

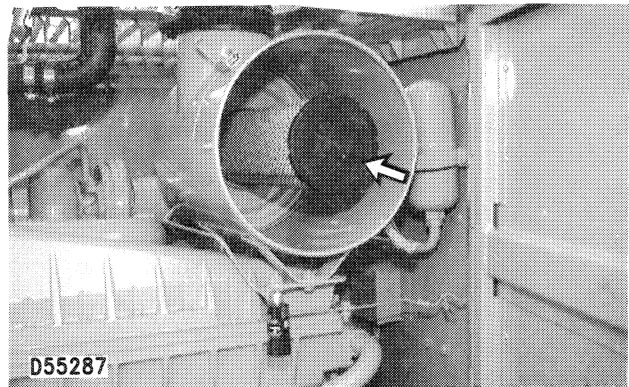

3. Remove the secondary element.

4. Cover the air inlet opening. Clean the inside of the air cleaner housing.

5. Uncover the air inlet opening. Install a new secondary element.

6. Install the primary element and cover.

7. Close the access cover.

8. Reset the filter element indicator.

## Cleaning Primary Elements

### NOTICE

Do not clean the filter elements by bumping or tapping them. Do not use filter elements with damaged pleats, gaskets or seals. Engine damage can result.

Make sure the cleaned filter elements are completely dry before installing into the filter housing. Water remaining in the elements can cause false indications of contamination in Scheduled Oil Sampling test results.

Filter elements can be cleaned with pressure air - 205 kPa (30 psi) maximum, pressure water - 280 kPa (40 psi) maximum, or detergent washing.

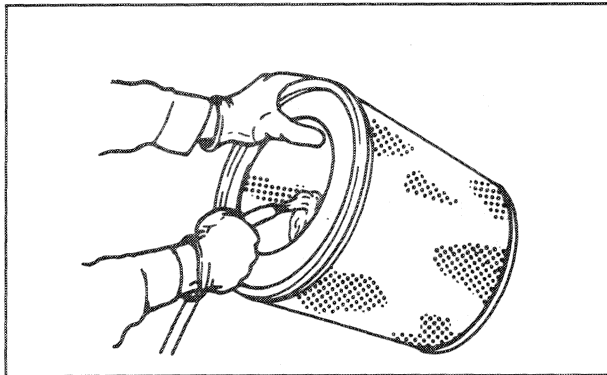

1. Direct air or water along the pleats inside and outside of filter element.

The element can be washed in warm water and nonsudsing household detergent. Rinse inside and outside the pleats and air dry fully.

2. Inspect the filter elements after cleaning. Do not use a filter element with damaged pleats or seals.
3. Wrap and store the clean filter elements in a clean, dry place.

## Ether Starting Aid (If Equipped)

### Installing the Cylinder

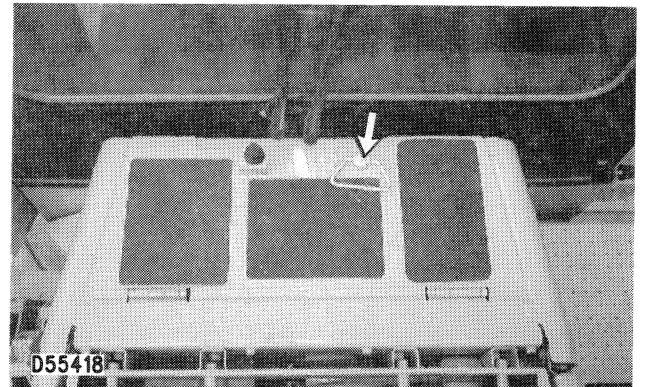

1. Open the access cover located behind the operator compartment on the rear of the machine. The ether cylinder is mounted on the right rear side of the compartment.

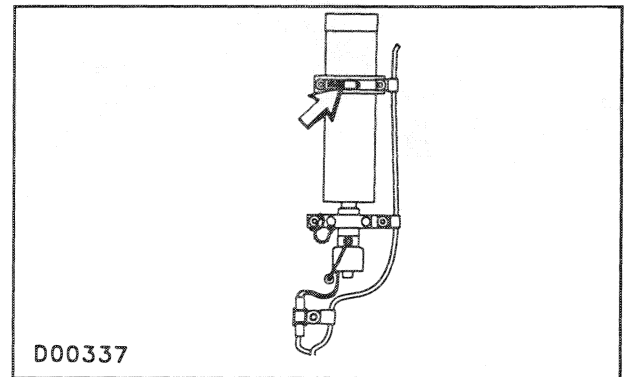

2. Loosen the cylinder retaining clamp, unscrew and remove the empty ether cylinder.
3. Remove the used gasket. Install the new gasket provided with each new cylinder.
4. Install the new cylinder. Tighten the cylinder hand tight. Tighten the cylinder clamp securely.
5. Close the access door.

## Fuses and Circuit Breakers

### Replace Fuses



Fuses – They protect the electrical system from damage caused by overloaded circuits. Change a fuse if the element separates. If the element of a new fuse separates, have the circuit checked and repaired.

#### NOTICE





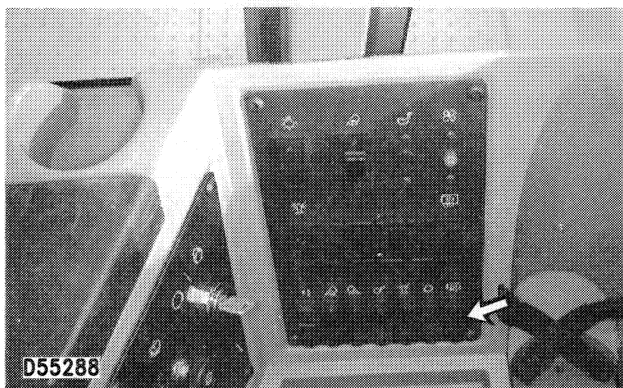



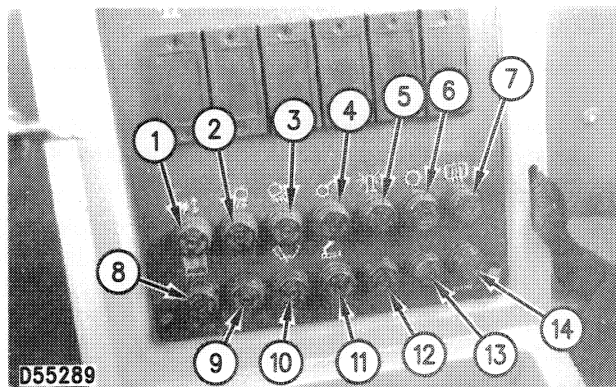

Replace the fuses with the same type and size only. Otherwise, electrical damage can result.

If it is necessary to replace fuses frequently, an electrical problem may exist. Contact your Caterpillar dealer.



The fuse panel is located in the right side control console in the cab.



-  Electric Converter and Air Dryer (If Equipped) (1) – 10 amps.
- 
-  Front Flood Lights (2) – 10 amps.
-  Rear Flood Lights (3) – 10 amps.
-  Transmission Shifter (4) – 10 amps.
-  Beacon (5) – 10 amps.
-  Autoshift (6) – 10 amps.
-  Rear Defroster (7) (If Equipped) – 10 amps.
-  Caterpillar Monitoring System Panel (8) – 10 amps.
-  Blank (9) – 10 amps.
-  Windshield Wipers (10) – 10 amps.





Lighter (11) – 10 amps.



Blank (12) – 10 amps.



Blade Kickout (13) – 10 amps.



Blank (14) – 10 amps.

The fuse panel is located in the engine compartment on the right side of the machine.

Open the lower engine compartment door and move the lever to open the upper engine compartment access door.

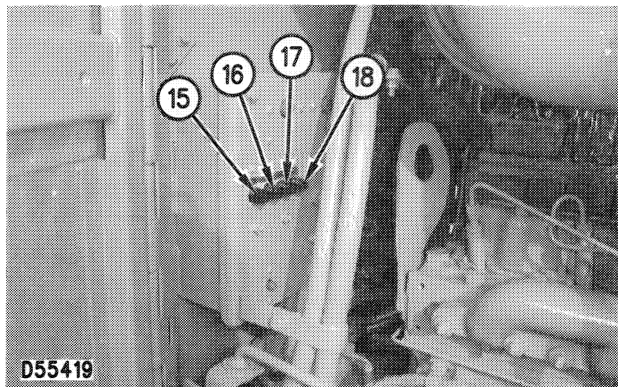

Stop Lights (15) – 10 amps.



Back-Up Alarm (16) – 10 amps.



Key Switch (17) – 10 amps.



Horn (18) – 10 amps.

### Reset Circuit Breakers

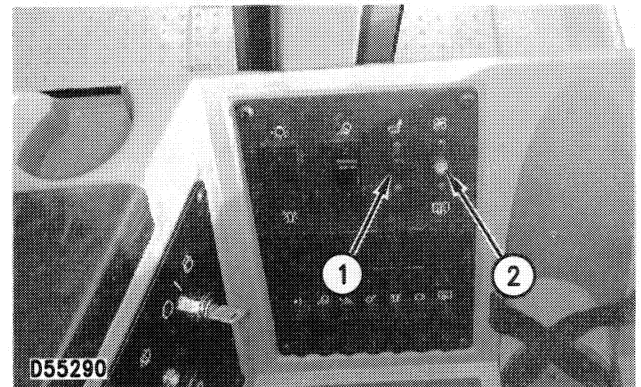

**Circuit Breaker Reset** – Push the button in to reset the circuit breakers. If working properly, the button will stay depressed. If the button does not stay in, or comes out shortly after being reset, have appropriate electrical circuit checked.

Circuit Breaker for the fan motor and seat air compressor is located in the control console in the cab.



Seat Air Compressor (1) (If Equipped) – 15 amps.



Fan Motor (2) – 15 amps.

Circuit Breakers are located in the engine compartment on the right side of the machine.

Open the lower engine compartment door and move the lever to open the upper engine compartment access door.

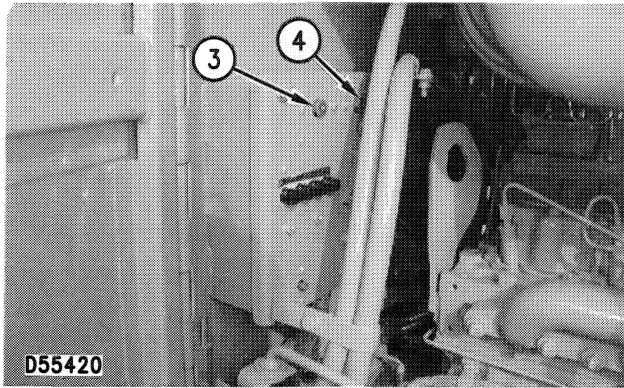

Alternator (3) – 80 amps.

Main (4) – 80 amps.

## Windshield Wipers and Washer

### Inspect/Replace



Inspect the front and rear windshield wiper blades. Replace if they are worn or damaged, or if streaking occurs.

### Fill Washer Bottle

---

#### NOTICE

When operating in freezing temperatures, use Caterpillar nonfreezing window washer solvent or equivalent. System damage can result from freezing.

---

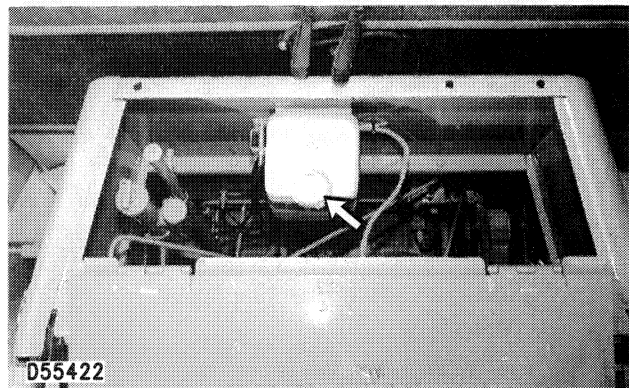

Open the access cover located behind the operator compartment on the machine. The windshield washer fluid bottle is located in the center of the compartment. The bottle can be filled through the filler opening.

## Cutting Edge and End Bits

### Change or Replace



1. Raise and block the blade. Stop the engine.

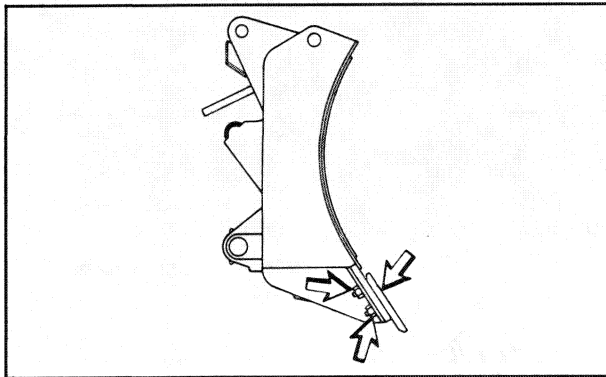

2. Remove the cutting edge and end bits. Clean all contact surfaces.

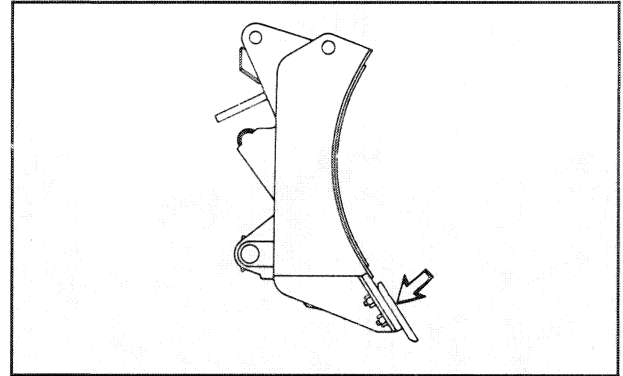

3. Use the opposite cutting edge if it is not worn (end bits are not reversible). Use a new section if both edges are worn.
4. Install all bolts and tighten them to the proper torque. See Torques for Ground Engaging Tool Bolts.
5. Start the engine, raise the blade and remove the blocks.
6. After a few hours of operation retighten all bolts to the proper torque.

## Tamping Tips (815F)

Inspect or Replace

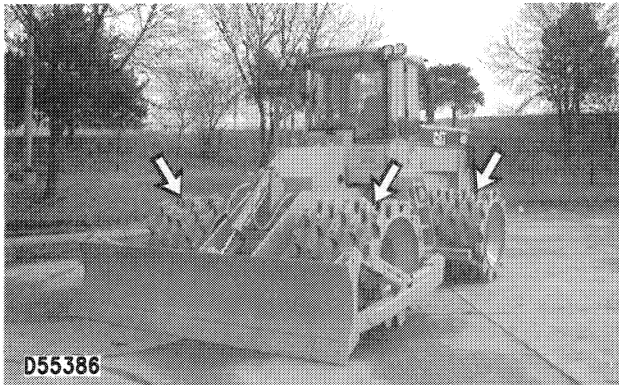

1. Inspect the tamping tips frequently.

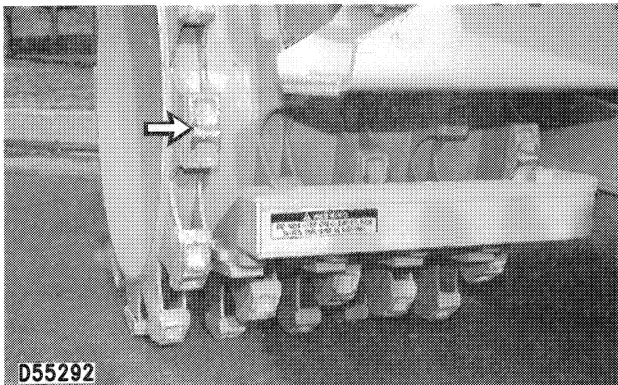

2. Replace all tamping tips that have worn through to the wear cavity.

## Cleaner Bar (815F)

Measure and Adjust

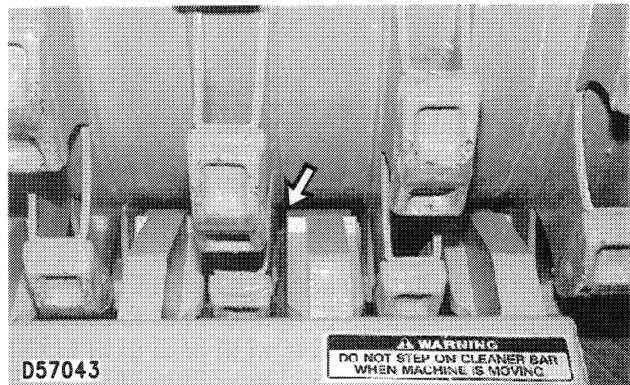
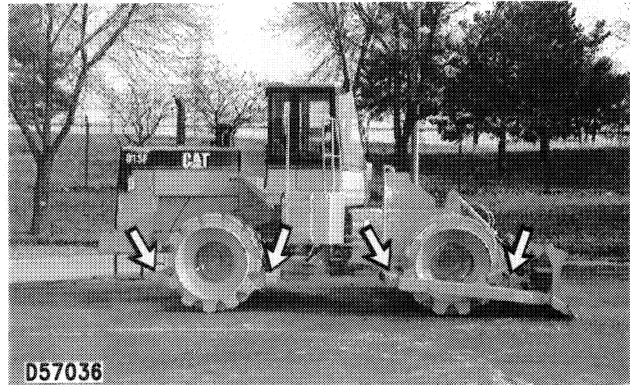

Measure the clearance between the scraper tip edges and the wheel. Correct clearance is 12 mm (½ in.). When the clearance reaches 25 mm (1.0 in.), adjust the scraper arms.

### To Adjust:

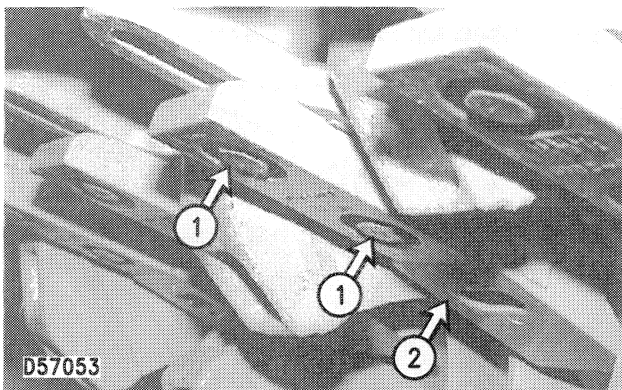

1. Loosen two bolts (1) and slide scraper arm (2) forward to the proper clearance.
2. Tighten the nuts to  $740 \pm 80 \text{ N}\cdot\text{m}$  ( $545 \pm 60 \text{ lb ft}$ ). Retorque all nuts after a few hours of operation.

### Replace Scraper Tips

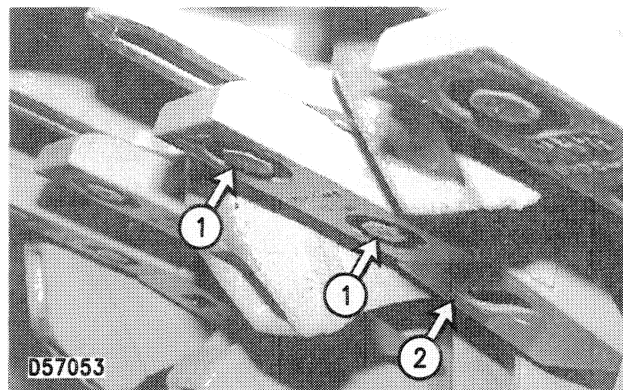

1. Loosen the two bolts (1) on the scraper bar (2) for each scraper arm.
2. Remove the two bolts and the scraper arm.
3. Drive the pin out of the tip from the retainer side of the tip. Remove the tip and the retainer.
4. Clean the adapter, the pin, and the retainer.
5. Install the retainer in the groove in the side of the adapter.
6. Install the new tip over the retainer. Drive the pin through from the side of the retainer.
7. Install the scraper arm on the cleaner bar with the two bolts. Slide the scraper arm, so the tip has the correct clearance (see preceding topic).
8. Tighten the bolts to  $740 \pm 80 \text{ N}\cdot\text{m}$  ( $545 \pm 60 \text{ lb ft}$ ). Retorque all bolts after a few hours of operation.

## Chopper Blades (816F)

### Inspect/Replace

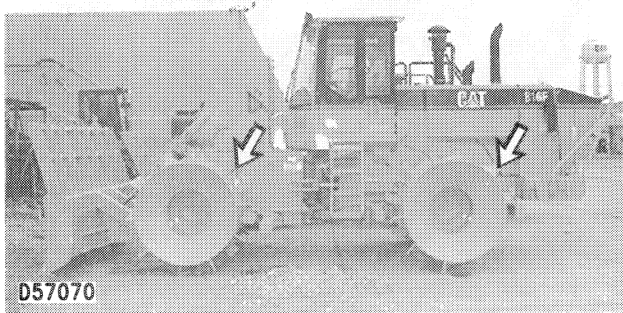

1. Inspect all chopper blades frequently.

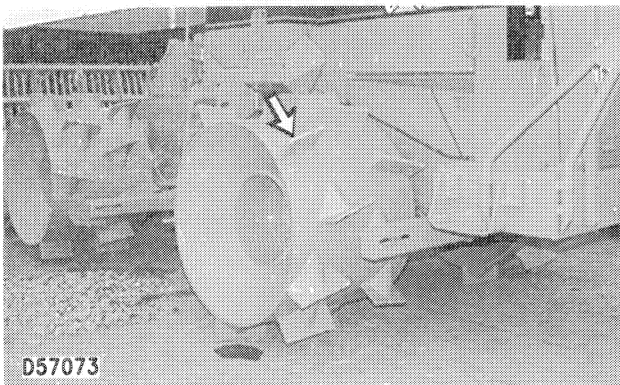

2. Replace the chopper blades before wear on the gussets occur.

## Filter Inspection

### Inspect Used Oil Filter for Debris

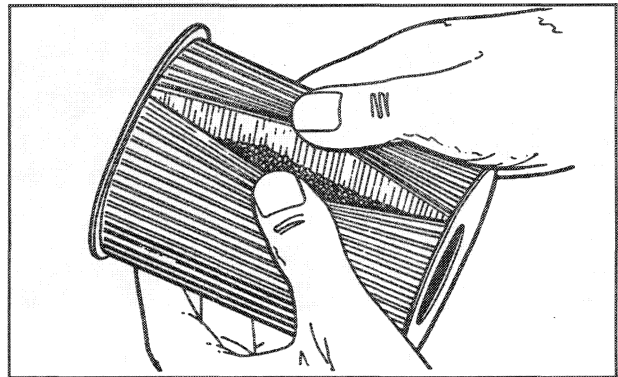

Element with debris

Use a 4C-5084 Filter Cutter to cut the filter element open. Spread pleats apart and inspect the element for metal and other debris. An excessive amount of debris in the filter element can indicate a possible failure.

Use a magnet to differentiate between ferrous and nonferrous metals found in the filter element.

Ferrous metals can indicate wear on the steel and cast iron parts.

Nonferrous metals can indicate wear on the aluminum parts of the engine, such as main, rod and/or turbocharger bearings.

Due to normal wear and friction, it is not uncommon to find small amounts of debris in the filter element. Consult your Caterpillar dealer to arrange for further analysis if an excessive amount of debris is found.

Use of an oil filter element not recommended by Caterpillar can result in severe engine damage to engine bearings, crankshaft and other parts. This can result in larger particles in unfiltered oil entering the lubricating system and causing damage.

## Every 10 Service Hours or Daily

*You must read and understand the warnings and instructions contained in the Safety section of this manual, before performing any operation or maintenance procedures.*

### Engine Oil

#### Check the Oil Level

---

#### NOTICE

Do not overfill the crankcase. Engine damage can result.

---

Measure the oil level with the machine level. Engage the transmission neutral lock and the parking/secondary brake. Lower the blade to the ground with slight down pressure.

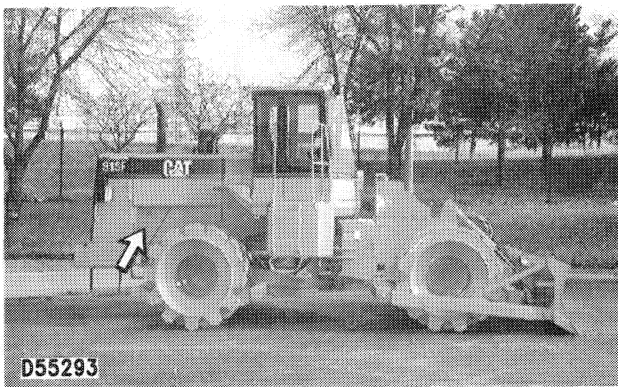

**1.** Open the access cover on the right rear of the machine. The oil level can be measured with the engine stopped or running and the oil warm.

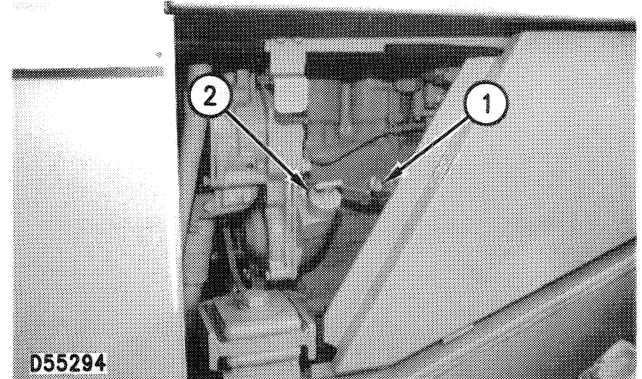

**2.** With the engine stopped, the oil level should be above the ADD mark on the ENGINE STOPPED side of the dipstick (1).

With the engine running, the oil level should be between the ADD and the FULL marks on the ENGINE RUNNING side of the dipstick (1).

- 3.** Remove the oil fill plug (2) and add oil if necessary.
- 4.** Clean and install the fill plug.
- 5.** Close the access cover.

## Transmission Oil

### Check the Oil Level

Measure the oil level with the machine level, the engine running at low idle, and the transmission neutral lock engaged. Lower the blade to the ground with slight down pressure and engage the parking/secondary brake.



1. Open the transmission access cover located behind the cab.

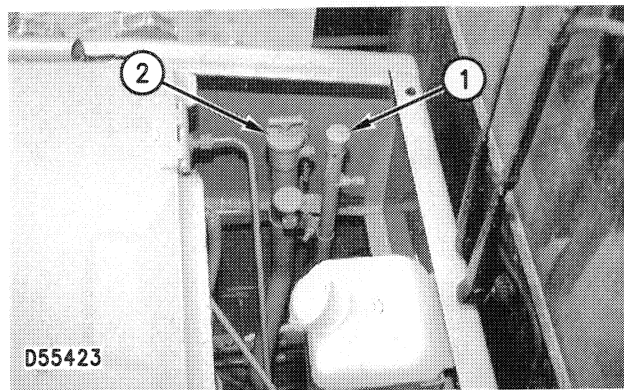

2. Maintain the oil between the ADD and FULL marks on dipstick (1).
3. Remove oil fill cap (2) and add oil if necessary.
4. Clean and install the fill cap.
5. Close the access cover. Stop the engine.

## Hydraulic Oil

### Check the Oil Level



The hydraulic oil tank is located on the right side of the machine.

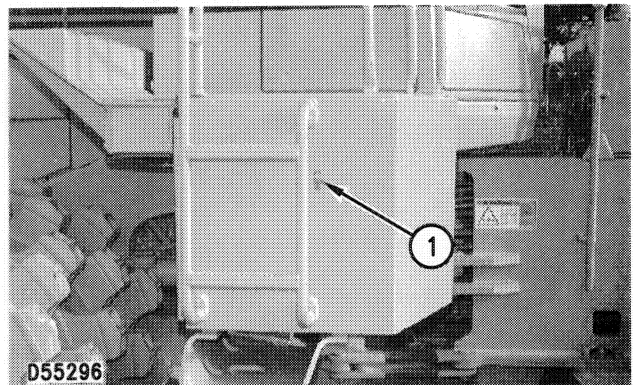

1. Maintain the oil level between the ADD and FULL marks on the dipstick.



2. Open the hydraulic oil tank cover.



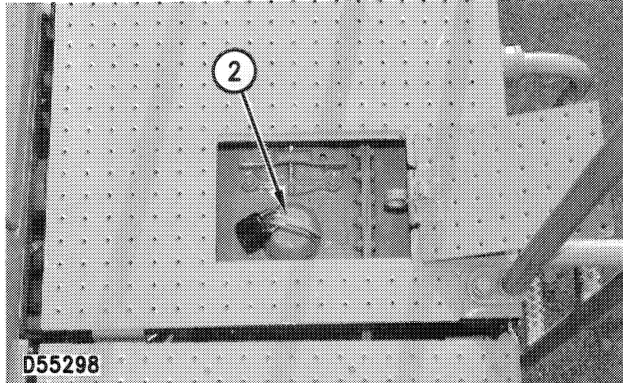

3. Remove the oil fill cap (2) slowly to relieve the pressure. Add oil, if necessary, through the fill tube.
4. Clean and install the fill cap.
5. Close the access cover.

## Cooling System

### Look at the Coolant Level



1. Maintain the coolant level in the sight gauge located on the right side of the machine. If it is necessary to add coolant daily, check for leaks.
2. Inspect the radiator core for debris and clean if necessary.

Compressed air is preferred, but high pressure water or steam can be used to remove dust, leaves and general debris from a radiator. Clean as required by condition of radiator.



The radiator cap is located in the top hood of the machine at the right rear.

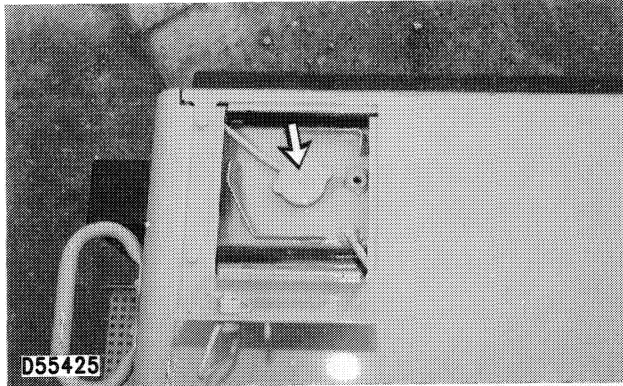

3. If coolant level is low, remove the radiator cap slowly to relieve pressure. Add Coolant as required to maintain coolant level in the sight gauge.
4. Inspect the cap and cap seal for damage, deposits or foreign material. Clean the cap with a clean cloth or replace the cap if it is damaged.
5. Install the cap.

## Fuel Tank

### Drain the Water and Sediment

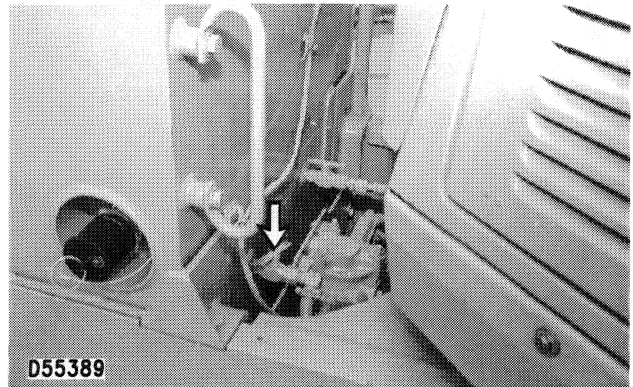

Drain valve is located at the left side of the machine behind the fuel tank.

1. Open the drain valve and allow the water and sediment to drain into a suitable container.
2. Close the drain valve.

## Walk-Around Inspection

### Inspect Machine

#### NOTICE

Accumulated grease and oil on a machine is a fire hazard. Remove this debris with steam cleaning or high pressure water, at least every 1000 hours or each time any significant quantity of oil is spilled on a machine.

NOTE: Keep a close watch for leaks. If leaking is observed, find the source and correct the leak. Check the fluid levels more frequently than the recommended periods if leaking is suspected or observed.



Inspect the engine precleaner screen for accumulation of dirt and debris. Make sure the air filter indicator piston is not in the red zone.

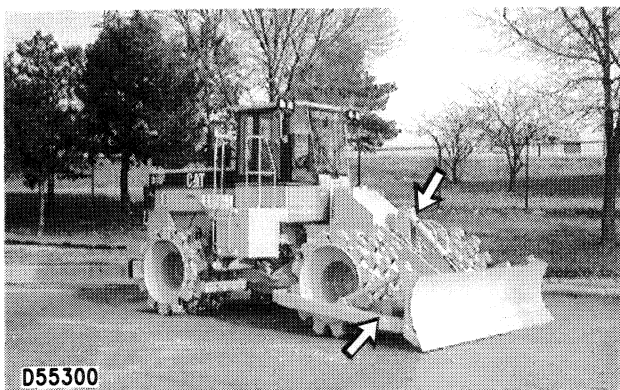

Inspect the dozer control linkage for damage or excessive wear. Repair if damaged.

Inspect the lights for broken bulbs and lenses. Replace if broken.

Inspect and remove any trash build-up in the engine compartment.

Inspect the cooling system for leaks, faulty hoses and trash build-up. Correct any leaks and remove any trash from the radiator.

Inspect all engine attachment belts for worn cracked or frayed edges. Replace if worn, cracked, frayed or broken.

Inspect the hydraulic system for leaks. Inspect the tank, cylinder rod seals, hoses, tubes, plugs, joints and fittings. Correct any leaks.

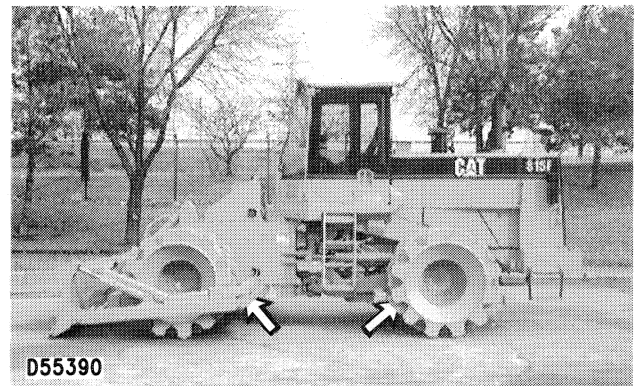

Inspect the differentials and final drives (front and rear) under the machine for leaks.

Inspect tires (front and rear) for damage and proper inflation. Replace any missing valve caps.

Inspect transmission for leaks.

Be sure the covers and guards are firmly in place. Inspect for damage.

Inspect the steps, walkways and handholds for their condition and cleanliness. Inspect the Rollover Protective Structure (ROPS) (if equipped) for damage. If repair is necessary contact your Caterpillar dealer.

Inspect the operator's compartment for cleanliness. Keep it clean.

Adjust the rear view mirrors for best vision.

## Cleaning Windows

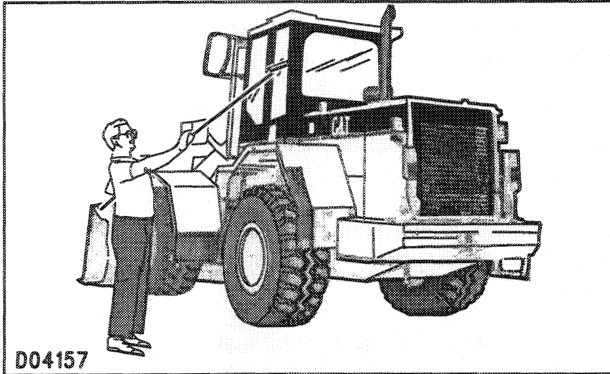

Use commercially available window cleaning solutions to clean the windows. Clean the outside windows from the ground, unless handholds are available.

## Cleaning Plastic Windows

The cab may be provided with plastic windows at the rear, both sides and front. They are shatter resistant, and reduce the need for vandalism protection.

Hairline scratches and minor abrasions can be removed, or minimized, by using a mild automotive or commercial wax. A thin, even coat of wax, polished by hand with a clean cloth, will help prevent further scratching.

---

### NOTICE

Care must be taken when cleaning these windows to prevent damage to the plastic.

Never use gasoline, benzine, acetone, carbon tetrachloride, fire extinguisher fluid, anti-ice fluid, lacquer thinner, acids, alkali, or glass cleaner to clean the plastic. These materials will attack the plastic and may cause it to weaken or break. Do not use abrasive cleaners.

Do not use scraper blades or other sharp instruments. Do not rub plastic with dry cloth since this builds up a static charge that attracts dust.

---

## Window Cleaning Methods

### Aircraft Windshield Cleaner

Apply the cleaner with a soft cloth. Rub with moderate pressure until all dirt is removed. Allow the cleaner to dry. Wipe off with a clean soft cloth.

### Soap and Water

Use a clean sponge or soft cloth. Wash windows with a mild soap or detergent, and plenty of lukewarm water. Rinse the windows thoroughly. Dry them with a moist chamois skin or moist cellulose sponge.

### Stubborn Dirt and Grease

Wash the windows in a good grade of naphtha, isopropyl alcohol or Butyl Cellosolve. Follow by washing them with soap and water.

## Seat Belt

Inspect for Wear or Damage

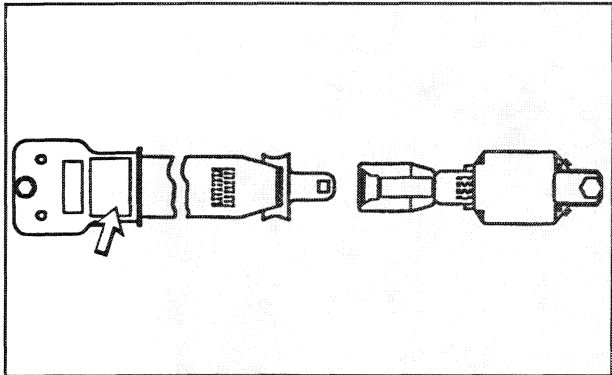

Replace the seat belt after three years of usage, regardless of appearance.

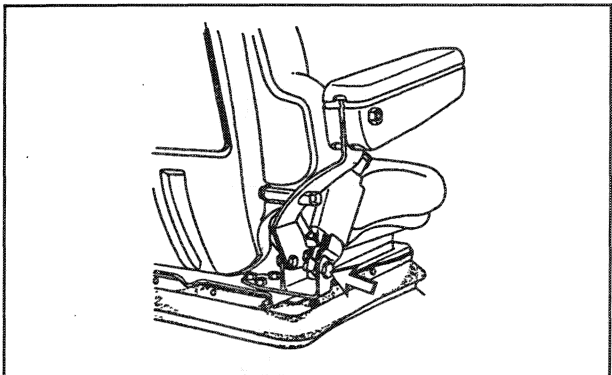

Seat belt and mounting hardware must be inspected for wear or damage before operating the machine. Replace the belt or mounting hardware if worn or damaged.

## Brakes, Indicators and Gauges

Test for Proper Function

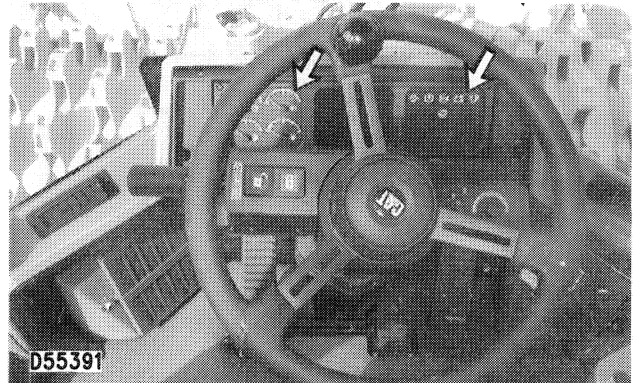

Look for broken gauge lenses or indicator lights, switches, etc.

Start the engine.

Look for inoperative gauges.

Turn all machine lights on. Check for proper operation.

Sound the horn.

Move the machine forward and test the service brakes. If service brakes do not function properly refer to the topic Brakes in the Every 250 Service Hours or Monthly section of this manual.

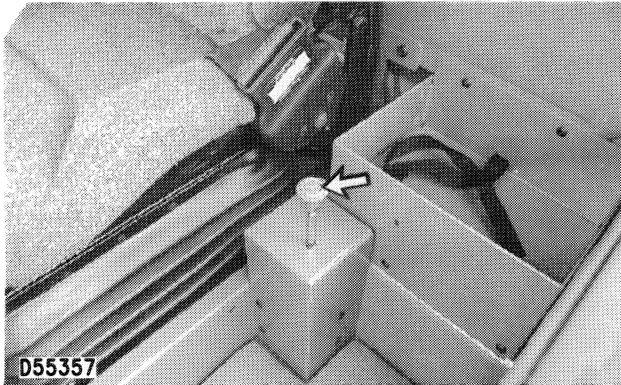

Move the machine forward and test the parking brakes. If parking brakes do not function properly refer to topic Brakes in Every 250 Service Hours or Monthly section of this manual.

Stop the engine.

Make any needed repairs before operating.

## Backup Alarm

### Test

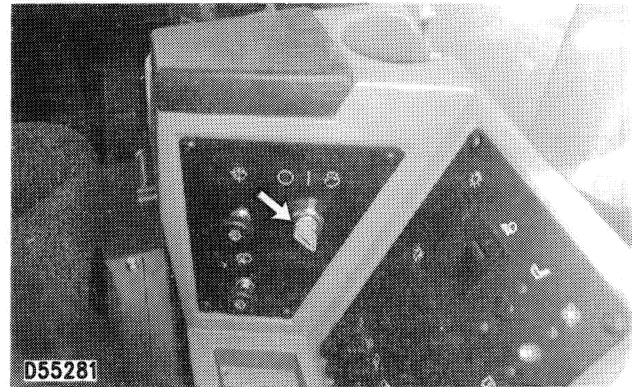

Turn the start switch to ON to perform the test.

Apply the service brake. Move the transmission control lever into REVERSE.

The alarm should start to sound immediately. It will continue to sound until the transmission control lever is moved to NEUTRAL or FORWARD.

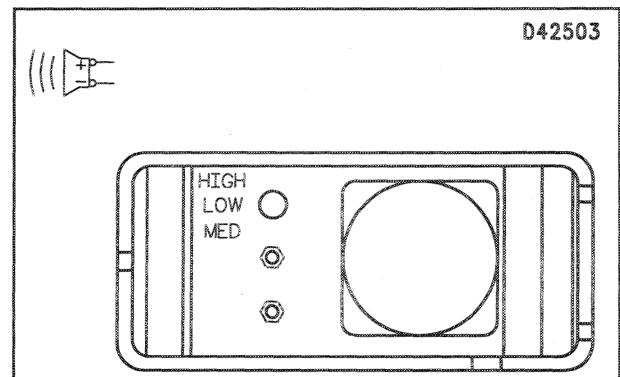

The sound level can be adjusted by moving the adjustment on back of alarm to meet operating requirements. The alarm is set at the highest sound level when shipped from the factory. The setting should remain on high, unless the job site requires a lower level.

The backup alarm is located on the rear of the machine.

## Every 50 Service Hours or Weekly

*You must read and understand the warnings and instructions contained in the Safety section of this manual, before performing any operation or maintenance procedures.*

### Cab Air System

#### Clean Filters

NOTE: Clean filters more often in dusty conditions.



**1.** Remove the filter cover located on the left side of the operator compartment near the floor.

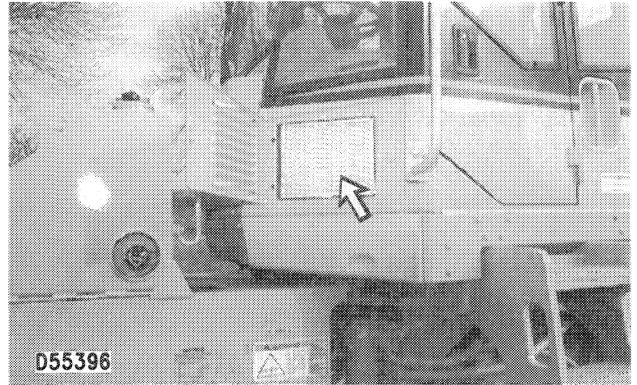

**2.** Open the filter covers located on both sides of the operator compartment.

**3.** Remove the filter elements. Clean the filter elements with pressure air or wash the elements in warm water and a nonsudsing household detergent.

**4.** Rinse in clean water and air dry thoroughly.

**5.** Install the filter elements. Close the filter covers.

## Every 100 Service Hours or 2 weeks

*You must read and understand the warnings and instructions contained in the Safety section of this manual, before performing any operation or maintenance procedures.*

### Rear Axle Trunnion

#### Lubricate Fittings

Wipe all fittings before lubricating.

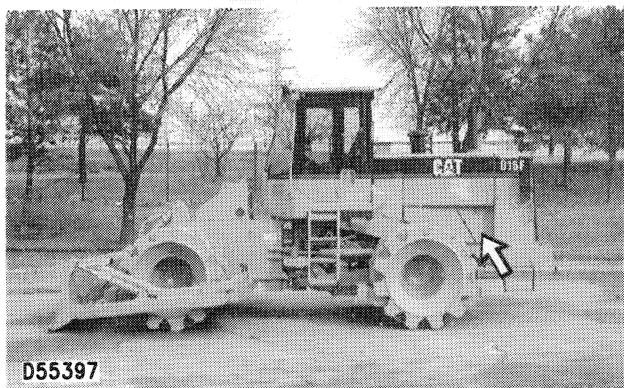

Open the engine access door on the left side of the machine.

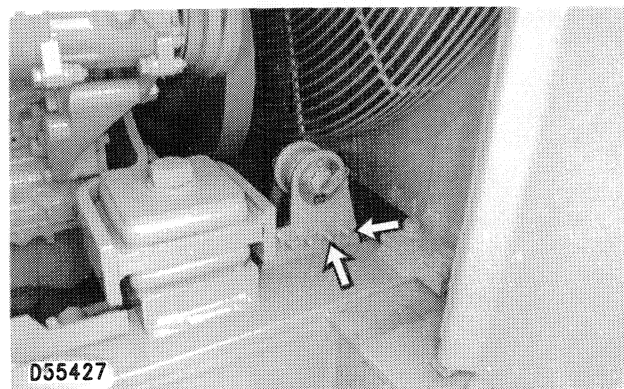

Lubricate two remote fittings located in the lube fitting block for the rear axle trunnion.

### Steering Cylinder Bearings

#### Lubricate Fittings

Wipe all fittings before lubricating.



Open the access door on the left side of the machine.

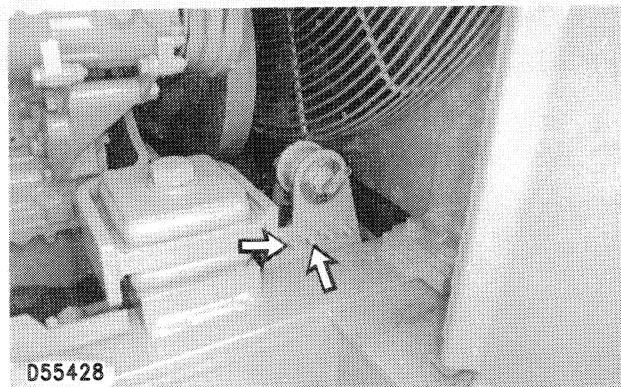

Lubricate two remote fittings located in the lube fitting block for the head end of the steering cylinders.



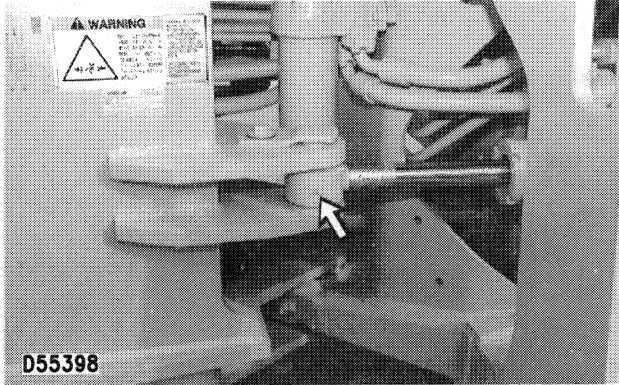

Lubricate one fitting in each eye of the rod end of the steering cylinders. Total of two fittings.

Total of four fittings.

## Bulldozer Stabilizer

### Lubricate the Fitting

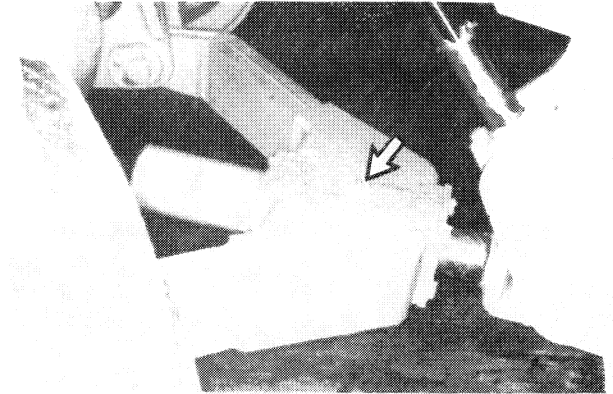

Lubricate one fitting.

### Bulldozer Cylinder Trunnion Bearing

Lubricate the Fittings

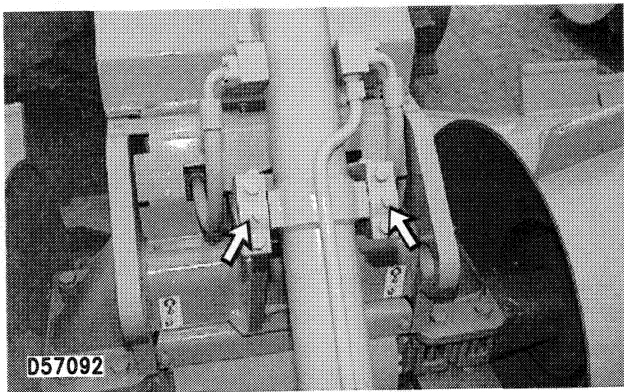

Lubricate two fittings.

### Bulldozer Cylinder Rod Bearing

Lubricate the Fitting

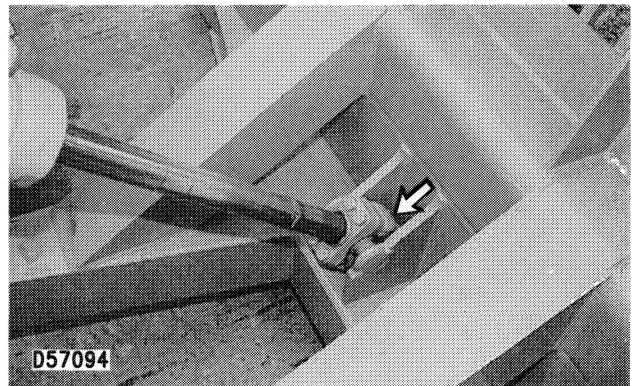

Lubricate one fitting.

## Every 250 Service Hours or Monthly

*You must read and understand the warnings and instructions contained in the Safety section of this manual, before performing any operation or maintenance procedures.*

### Engine Oil and Filter

#### Change the Oil and Filter

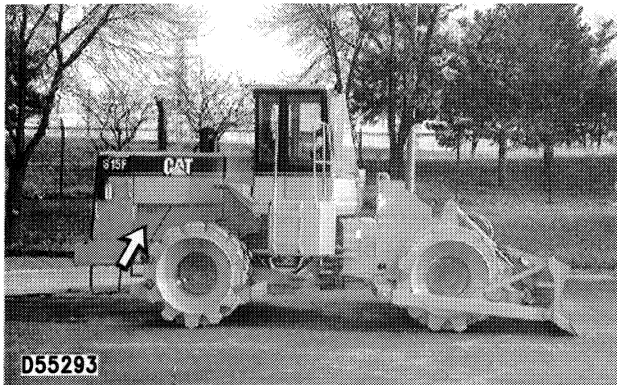

1. Open the engine access covers on the right side of the machine.

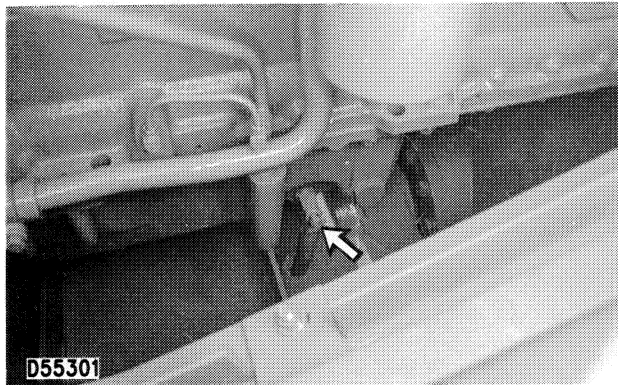

2. Open the crankcase drain valve. Allow the oil to drain into a suitable container. Close the drain valve.

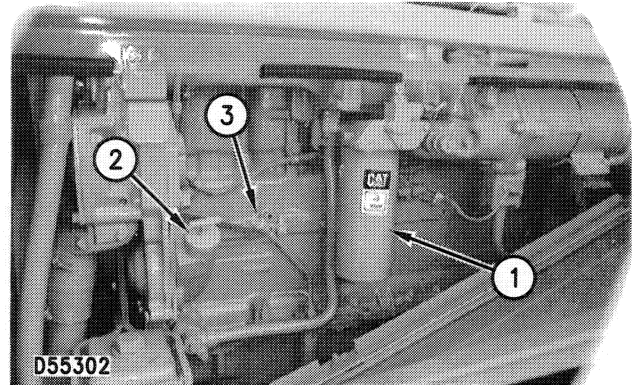

3. Remove the filter element (1) with a strap-type wrench. Refer to Filter Inspection in the When Required section.
4. Clean the filter housing base. Make sure all of the old filter gasket is removed.
5. Apply a light coat of engine oil to the gasket of the new filter.
6. Install the new filter by hand. When the gasket contacts the filter base, tighten the filter three-quarter of a turn more.
7. Remove the oil fill plug (2). Fill the crankcase with new oil. See the Lubricant Viscosities and Refill Capacities. Clean and install the fill plug.
8. Start the engine and allow the oil to warm. Check for leaks.
9. With the engine running, maintain the oil on the dipstick (3) between the marks on the low idle side of the dipstick. Add oil if necessary.
10. Stop the engine.
11. Close the engine access covers.

## Engine Crankcase Breather

### Clean Breather



1. Open the engine access doors located on the right side of the machine.

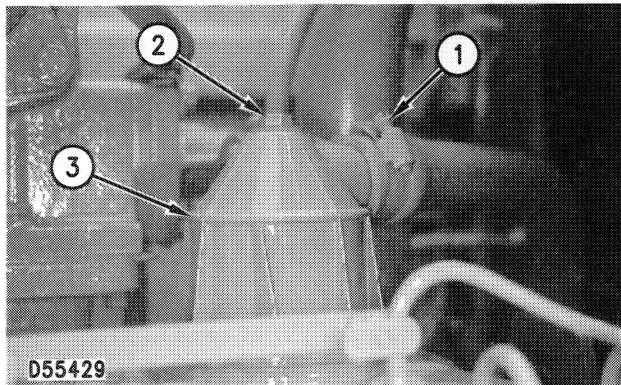

2. Loosen the breather outlet hose clamp (1) and remove the hose from the breather cover.
3. Loosen the breather bolt (2) and remove the breather (3).
4. Check the condition of cover seal. Replace with new seal if the used one is damaged.
5. Wash the element and cover assembly in clean, nonflammable solvent.
6. Shake, or use pressure air, to dry the element.
7. Inspect the hose for damage. Replace if necessary.
8. Install the breather element cover assembly.
9. Install the hose and clamps.
10. Close the engine access doors.

## Cooling System

### Add Supplemental Coolant Additive/Replace Element

NOTE: This procedure pertains only to machines using conventional antifreeze/coolant.

Refer to the Cooling System Specifications section of this manual for all cooling system requirements.

Use the 8T-5296 Test Kit to check for concentration.

---

#### NOTICE

Excessive additive (greater than the recommended 6% initial fill) together with concentrations of anti-freeze greater than 60% cause deposits to form and can result in radiator tube blockage and overheating.

---

### Liquid Supplemental Coolant Additive

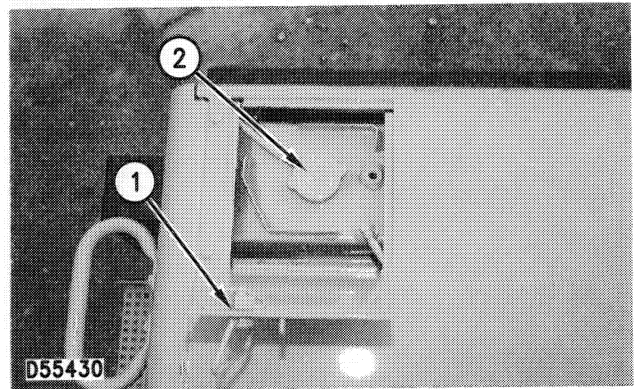

1. Open the access cover (1). Loosen the fill cap (2) slowly to relieve pressure and remove the cap.
2. It may be necessary to drain enough coolant from the radiator to allow for the addition of the liquid cooling system additive.
3. Add .24 liters (.50 pint) of additive for every 38 liters (10 U.S. gallons) of cooling system capacity.
4. Install the fill cap and close the access cover.

## Brakes

### Test Service Brake Holding Ability

#### **WARNING**

**Personal injury can result if the machine moves while testing.**

**If the machine begins to move during test, reduce the engine speed immediately and engage the parking brake.**

Be sure the area around machine is clear of personnel and obstructions.

Be sure the steering frame lock link is in the stored position.

Test the brakes on a dry, level surface.

Fasten the seat belt before testing the brakes.

The following tests are to determine if the service brake is functional. These tests are not intended to measure maximum brake holding effort. Brake holding effort required to hold a machine at a specific engine rpm will vary from machine to machine. This is due to differences in engine setting, power train efficiency, etc., as well as differences in brake holding ability.

Engine rpm at beginning of machine movement, with service brake applied, should be compared against a prior test. Use the test as an indication of system deterioration.

**1.** Start the engine, and raise the dozer blade slightly. Apply the service brake and release the parking brake.

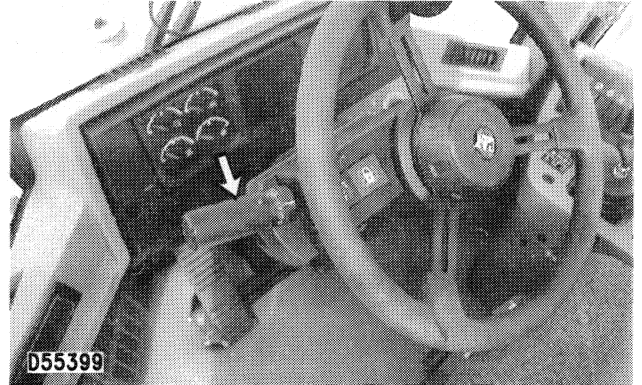

**2.** Move the transmission to second speed forward.

**3.** Gradually increase the engine speed to high idle. The machine should not move.

**4.** Reduce the engine speed to low idle, move the transmission to NEUTRAL. Engage the parking brake, lower the dozer blade to the ground and stop the engine.

#### **NOTICE**

**If the machine moved while testing the brakes, contact your Caterpillar dealer. Have the dealer inspect and, if necessary, repair the service brakes before returning the machine to operation.**

### Test Parking Brake Holding Ability

Be sure the area around machine is clear of personnel and obstructions.

Be sure the steering frame lock link is in the stored position.

Test the brakes on a dry, level surface.

Fasten the seat belt before testing the brakes.

The following tests are to determine if the parking brake is functional. These tests are not intended to measure maximum brake holding effort. Brake holding effort required to hold a machine at a specific engine rpm will vary from machine to machine. This is due to differences in engine setting, power train efficiency, etc., as well as differences in brake holding ability.

Engine rpm at beginning of machine movement, with parking brake engaged, should be compared against a prior test. Use this as an indication of system deterioration.

1. Start the engine, and raise the dozer blade slightly.
2. With the parking brake engaged, move the transmission to second speed REVERSE.

NOTE: The parking brake alert indicator should come on and the action alarm should sound.

3. Gradually increase the engine speed to high idle. The machine should not move.

**! WARNING**

**Personal injury can result if the machine moves while testing.**

**If the machine begins to move, reduce the engine speed immediately and apply the service brake pedal.**

4. Reduce the engine speed, move the transmission to NEUTRAL. Lower the dozer blade to the ground and stop the engine.

**NOTICE**

If the machine moved while testing the parking brakes, contact your Caterpillar dealer. Have the dealer inspect and, if necessary, repair the parking brakes before returning the machine to operation.

**Test Brake Accumulator**

1. Turn the engine start switch to ON.

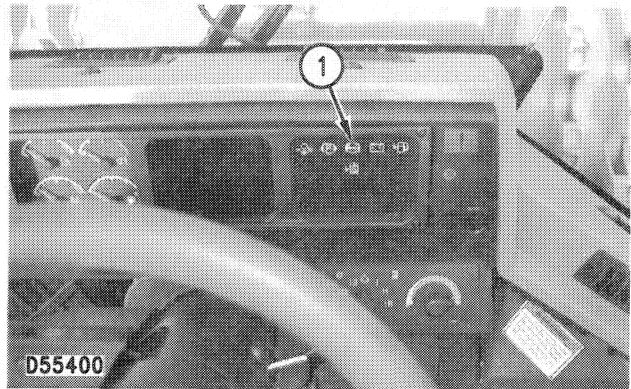

2. The brake oil pressure indicator light (1) should come on if not at normal operating pressure.
3. Start and run the engine at half speed for two minutes to increase the accumulator pressure. The brake oil pressure indicator light (1) should go off. Stop the engine.

4. Apply and release the service brake pedal, to decrease the accumulator pressure, until the brake oil pressure indicator light comes on (minimum of five applications).

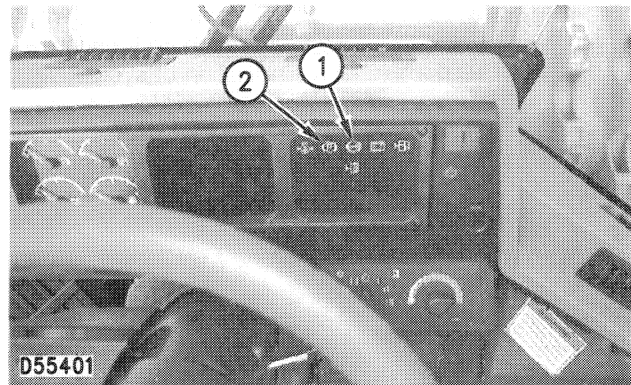

5. The parking brake indicator light (2) will be on when the brake oil pressure indicator light comes on.

6. If the brake oil pressure indicator light (1) comes on with less than five applications of the brake, measure the accumulator nitrogen precharge pressure. Your Caterpillar dealer is equipped to measure the nitrogen gas pressure in the accumulator. Use only dry nitrogen gas for recharging.

## Drive Shaft Spline

### Lubricate Fitting

Wipe all fittings before lubricating.

1. Start the engine, raise the dozer blade, release the parking brake and articulate the machine full right or left.

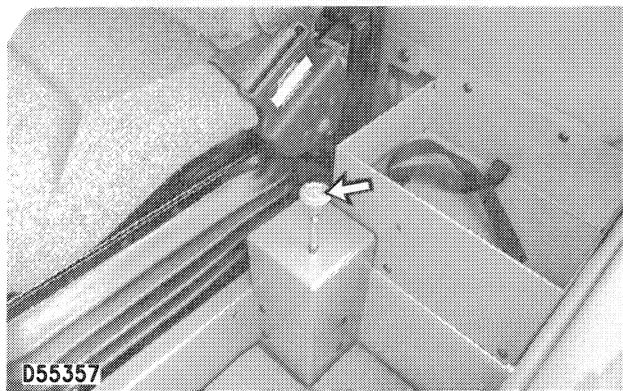

2. Lower the dozer blade to the ground, engage the parking brake and stop the engine.

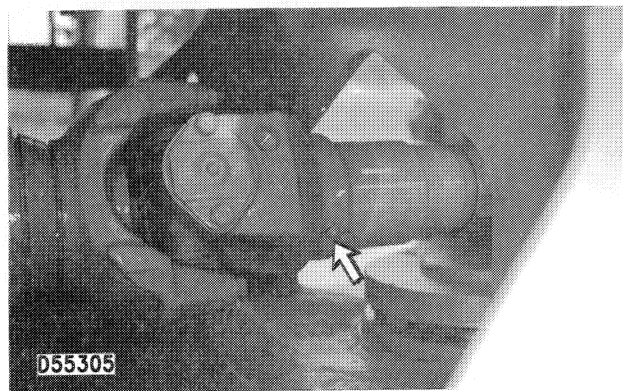

3. Lubricate one fitting on the drive shaft spline.

## Fan Bearing

### Lubricate Fitting

Wipe all fittings before lubricating.



1. Open the right engine access door.

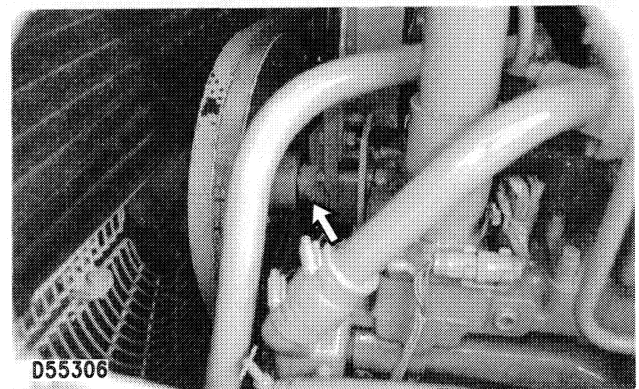

2. Lubricate one fitting on the fan bearing.
3. Close the engine access door.

## Air Conditioner (If Equipped)

### WARNING

Inhaling air conditioner refrigerant gas through a lit cigarette or other smoking method or inhaling fumes released from a flame contacting air conditioner refrigerant gas can cause bodily harm or death. Do not smoke when servicing air conditioners or wherever refrigerant gas may be present.

### Test Operation - Adjust Belt

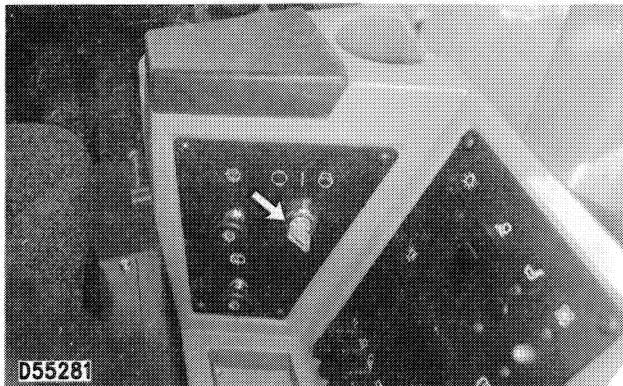

1. Start the engine. Operate the engine at high idle.

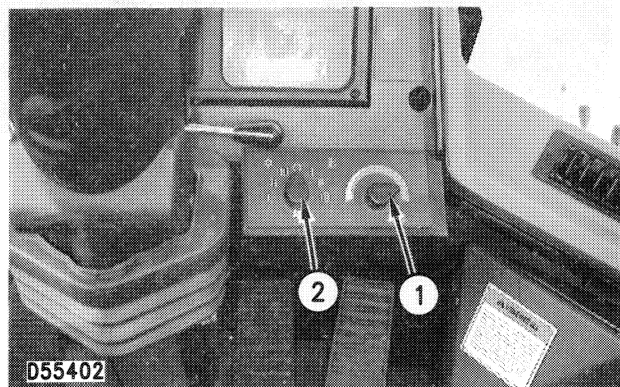

2. Set the air conditioner control (1) for maximum cooling, and fan control (2) on HIGH.
3. Allow two minutes for the air conditioning system to stabilize.

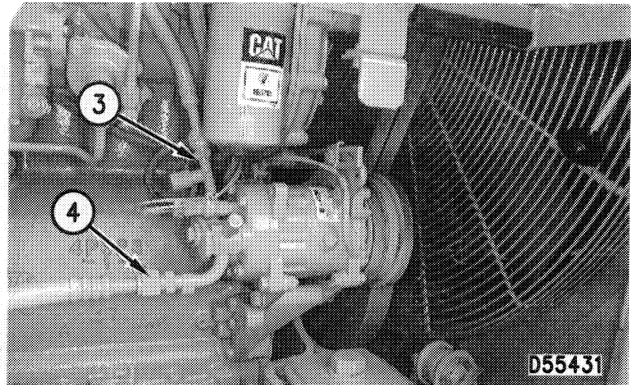

4. Check for refrigerant in the system as follows: Feel the suction line (3) and the discharge line (4).

If the system contains refrigerant, the discharge line will be warmer than the suction line.

If the system does not contain, or is very low on refrigerant, poor cooling will result.

5. Stop the engine to inspect the compressor belt.

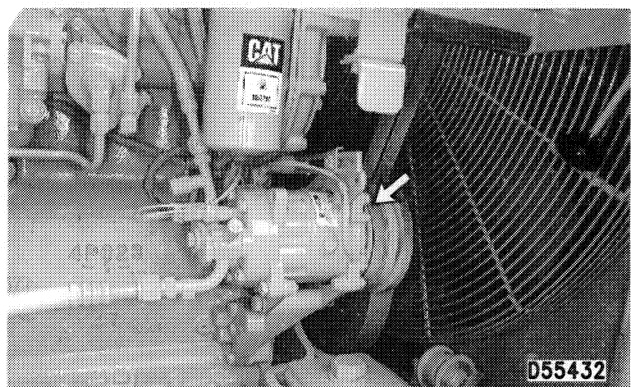

6. Inspect the condition and the adjustment of the compressor belt. The belt should deflect 14 to 20 mm (.56 to .81 in) under 110 N (25 lb) force.



### To Adjust

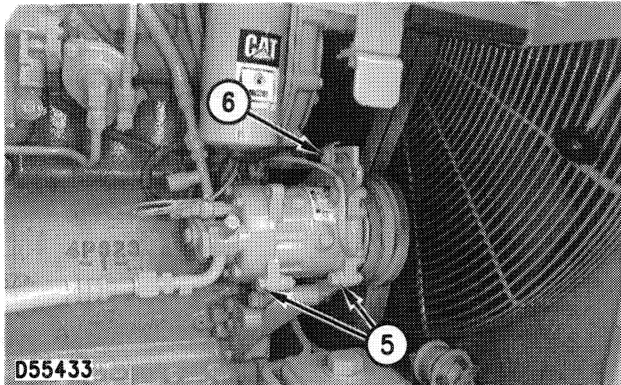

1. Loosen the compressor bracket mounting bolts (5).
2. Loosen the adjusting nut (6).
3. Move the compressor until the correct belt tension is reached.
4. Tighten the adjusting nut (6).
5. Tighten the compressor bracket mounting bolts (5).
6. Recheck the belt adjustment.
7. Repeat steps 1 through 5.
8. If poor cooling is still experienced after starting engine, turn off the air conditioner. Stop the engine. Contact your Caterpillar dealer for air conditioner system service, if necessary.

## Fan and Alternator Belts

### Inspect-Adjust-Replace



1. Open the engine access cover on the left side of the machine.

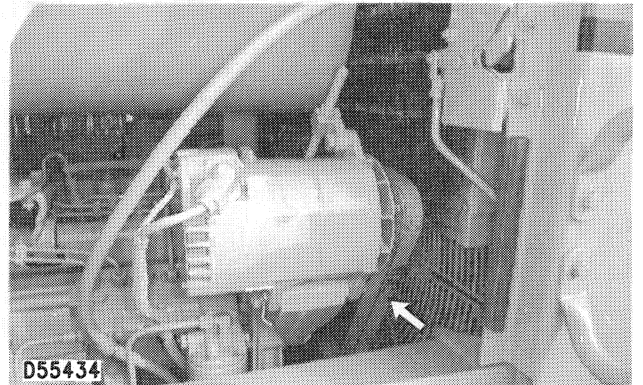

2. Inspect the condition and the adjustment of belts. Replace the belts in sets only, if one or more are worn or damaged.

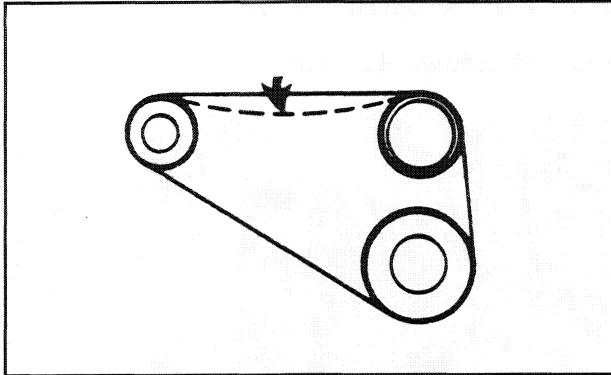

Measure the deflection of the belts. The belts should deflect 14 to 20 mm ( $\frac{9}{16}$  to  $\frac{13}{16}$  inch) under 110 N (25 lb) force midway between the pulleys.

### To Adjust

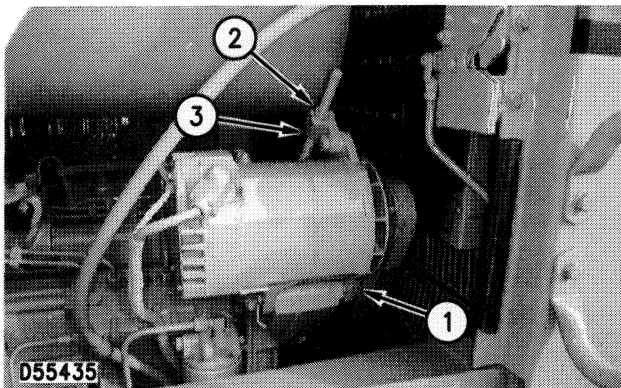

1. Loosen the alternator bracket mounting bolt (1).
2. Loosen the adjusting rod lock nut (2).
3. Tighten the adjusting nut (3) until the correct belt tension is reached.
4. Tighten the adjusting rod locknut to  $150 \pm 20 \text{ N}\cdot\text{m}$  ( $110 \pm 15 \text{ lb ft}$ ).
5. Tighten the alternator bracket mounting bolt (1).
6. Recheck the belt deflection.
7. If the belt deflection is not correct, repeat steps 1 through 6.
8. Install the engine access cover.

## Batteries

### Check Electrolyte Level

| BATTERY ELECTROLYTE CHART |               |
|---------------------------|---------------|
| Battery                   | Interval      |
| Conventional              | 100 Hour      |
| Low Maintenance           | 250 Hours     |
| Hybrid                    | 1000 Hours    |
| Maintenance Free          | None Required |

Tighten the battery retainers every 1000 hours on all batteries.

Check the following at least every 1000 hours, and more often as conditions require:

- Clean the top of the batteries with a clean cloth.
- Keep the terminals clean.

Check the cells more frequently in extreme temperatures, cell water usage could be higher.

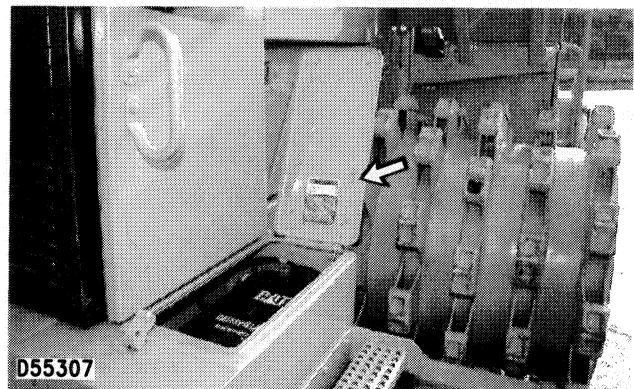

1. Open the battery access covers located on each side at the rear of the machine.
2. Clean the battery surface with a clean cloth. Keep the terminals clean. If using corrosion protection coating, use only after the cable is connected.
3. Inspect the electrolyte level in each battery cell, except maintenance free. Maintain the level to within one quarter inch of the bottom of the filler tubes with distilled water. If distilled water is not available, use clean drinking water.
4. Close the access cover.

### **Replacement of Battery, Battery Cable or Disconnect Switch**

- 1.** Turn the engine start switch to OFF. Turn all switches to the OFF position.
- 2.** Turn the battery disconnect switch key to OFF and remove the key.
- 3.** Disconnect the negative (-) battery cable, at the battery disconnect switch, that is connected to the machine frame.

NOTE: Do not allow the disconnected battery cable to contact the disconnect switch.

- 4.** Disconnect the negative (-) battery cable at the battery.
- 5.** Disconnect the positive (+) battery cable at the battery.
- 6.** Make necessary repairs and cable or battery replacement.
- 7.** Connect the positive (+) battery cable at the battery.
- 8.** Connect the negative (-) battery cable at the battery.
- 9.** Connect the battery cable at the battery disconnect switch.
- 10.** Install the key and turn the battery disconnect switch to ON.

### **Battery Recycling**

- 1.** A battery should always be recycled and never discarded.
- 2.** A used battery must be returned to a battery dealer or to an authorized battery collection or recycling facility.

## Every 500 Service Hours or 3 Months

*You must read and understand the warnings and instructions contained in the Safety section of this manual, before performing any operation or maintenance procedures.*

### Transmission Oil Filter

#### Change Filter

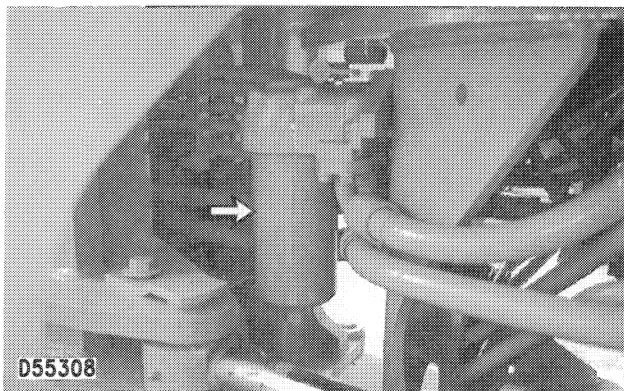

1. The transmission filter is located at the center of the machine.
2. Use a strap-type wrench or a cross bar to remove the filter housing.
3. Remove and discard the used element.
4. Clean the filter housing with a clean, nonflammable solvent.
5. Clean the housing base.
6. Insert a new filter element into the filter housing.
7. Inspect the filter housing seal. Replace the seal, if it is damaged.
8. Install the filter housing into the housing base.

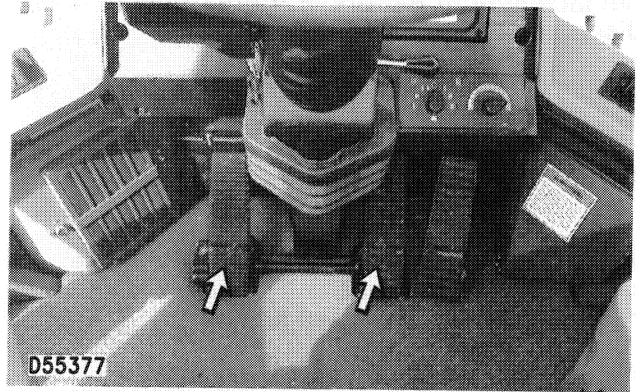

9. Start the engine. Apply the service brakes.



10. Slowly operate the transmission controls to circulate the transmission oil.
11. Move the transmission control lever into NEUTRAL. Engage the parking brake. Inspect for leaks.

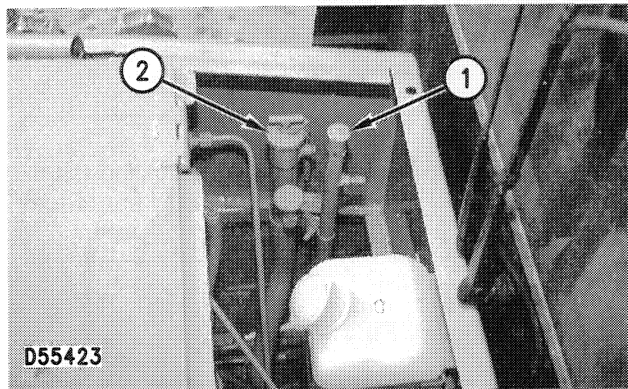

**12.** Maintain the oil level between the marks on dipstick (1) located behind the cab on the right side of the machine. Add the oil through fill tube (2) if necessary.

**13.** Stop the engine.

## Hydraulic System

### Change the Filters



The hydraulic tank is on the right side of the machine.



**1.** Remove two bolts and swing the platform away from the hydraulic tank.

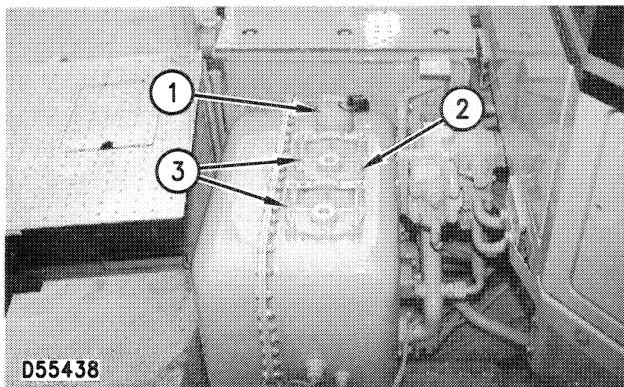

**2.** Remove the oil filler cap (1) slowly to relieve the tank pressure.

3. Loosen the filter housing cover retaining bolts (2).
4. Remove the covers (3) and filter elements.
5. Discard the filter elements.
6. Clean the covers and inspect the condition of the "O" ring seals. Replace if necessary.
7. Install new filter elements. Install the covers. Tighten the cover retaining bolts to  $58 \pm 4 \text{ N}\cdot\text{m}$  ( $43 \pm 3 \text{ ft lb}$ ).

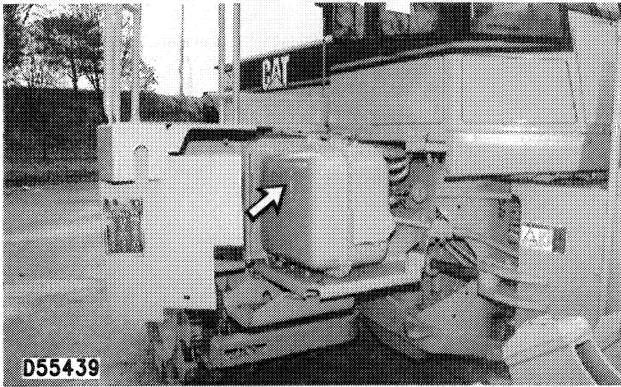

8. Maintain the hydraulic oil to the FULL mark in the sight gauge. Add oil if necessary through the fill tube.
9. Inspect the filler cap gasket. Replace the gasket, if it is damaged. Install the oil filler cap.
10. Close the platform and install the two bolts.

## Fuel System

### Clean and Change Filters

#### NOTICE

Do not fill fuel filters with fuel before installing them. Contaminated fuel will cause accelerated wear to fuel system parts.

### Wash the Primary Filter Element



1. Open the engine access door located on the left side of the machine.

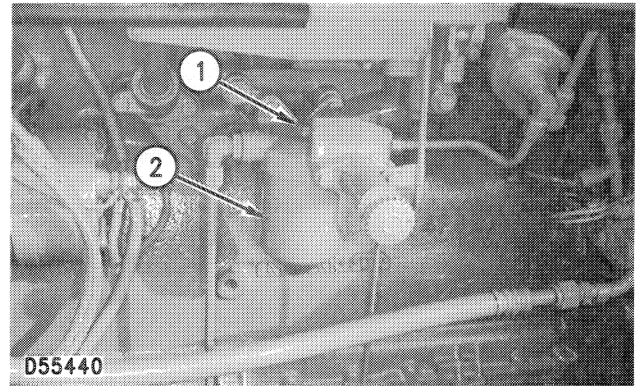

2. Loosen the filter housing retaining bolt (1).
3. Remove the housing (2) and element.
4. Remove the element from the case.
5. Wash the element and housing in clean, nonflammable solvent.

6. Dry the element using pressure air.
7. Clean the filter case base.
8. Inspect the seal. Replace if damaged.
9. Insert the clean element.
10. Install the element and case into housing.
11. Retighten the retaining bolt (1) to a torque of  $24 \pm 4$  N•m ( $18 \pm 3$  lb ft).

### Change Secondary Fuel Filter



1. Remove and discard the filter.
2. Clean the filter mounting base. Be sure all of the old seal is removed.
3. Coat the seal of a new filter with clean diesel fuel.
4. Install the new filter by hand. When the seal contacts the base, tighten three-quarter of a turn more.

There are rotation-index marks  $90^\circ$  apart on the filter. Use them as a guide for proper tightening.

5. Prime the fuel system. (See Priming the Fuel System).

NOTE: Change the secondary filter more often if needed. In areas subject to dirty fuel conditions, a 250 service hour interval or less is recommended.

### Priming the Fuel Filters

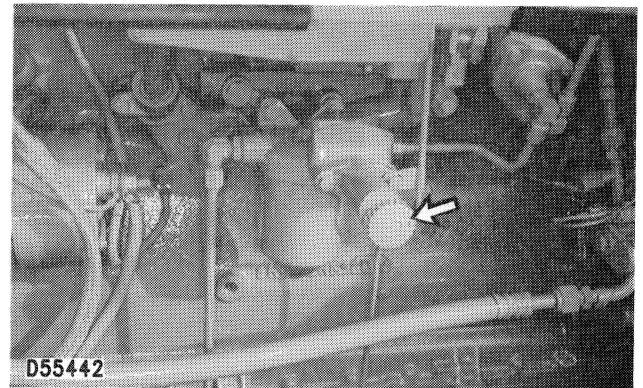

1. Turn the priming pump plunger (counterclockwise) and pull out to unlock and operate the plunger.
2. Operate the plunger to fill the new filter elements with fuel. Continue pumping until a resistance is felt, indicating the elements are full of fuel.
3. Push in and turn (clockwise) to lock the priming pump plunger.
4. Start the engine and check for leaks.
5. Stop the engine.

## Priming the Fuel System

The injection pumps and high pressure lines must be primed if the engine will not start, or runs rough, after priming the filters and pump housing.

Each injection pump has a reverse flow check valve. These cannot be opened with hand priming pump pressure. Use the following procedure to prime the injection pumps and lines.

---

### NOTICE

The fuel injection nozzles can be permanently damaged by twisting if only one wrench is used to loosen or tighten the fuel line nuts. Use one wrench to hold the nozzle and another to loosen the nut.

---

1. Loosen the fuel injection lines at the cylinder head of the engine.
2. Move the governor control lever to the LOW IDLE position.
3. Turn the start switch key to START. Crank the engine, until the fuel flows free of air bubbles, from all fuel lines. Stop cranking the engine.
4. Tighten the fuel line nuts to a torque of  $40 \pm 7$  N•m ( $30 \pm 5$  lb ft). Use a second wrench on the nozzle to prevent damage to it.
5. Start the engine and check for leaks.
6. Stop the engine.

## Fuel Tank Cap and Fill Screen

### Clean

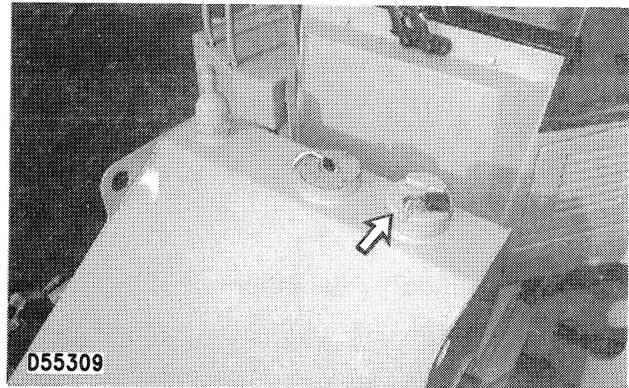

The fuel cap is located on the left side of the machine in front of the cab.



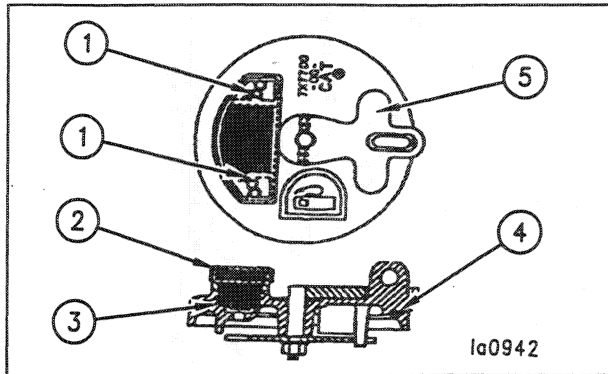

1. Lift and turn the lever (5) counterclockwise until it stops. Lift the cap straight up to remove.
2. Inspect the seal (4) for damage. Replace the seal if necessary.
3. Remove the screws (1), filter assembly (2), valve (3) and gaskets.
4. Wash the cap in a clean nonflammable solvent.
5. Install the new filter kit. Install components in reverse order.
6. Remove the fill screen from the fill opening.
7. Wash the fill screen in a clean nonflammable solvent.
8. Install the fill screen into the fill opening.
9. Install the fuel cap.

## Every 1000 Service Hours or 6 Months

*You must read and understand the warnings and instructions contained in the Safety section of this manual, before performing any operation or maintenance procedures.*

### Transmission Oil

#### Change the Oil

Operate the engine long enough to warm the oil. The machine must be level. Lower the dozer blade to the ground with slight down pressure.

Engage the parking brake and the transmission neutral lock. Stop the engine.

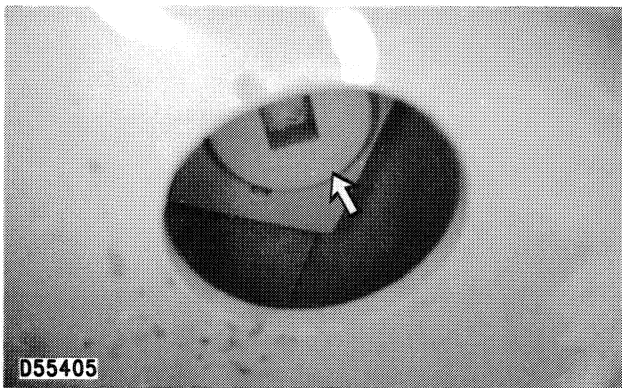

1. Remove the transmission drain plug and allow the oil to drain into a suitable container.
2. Change the filter element. See the topic "Transmission Oil Filter" under "Every 500 Service Hours or 3 Months".

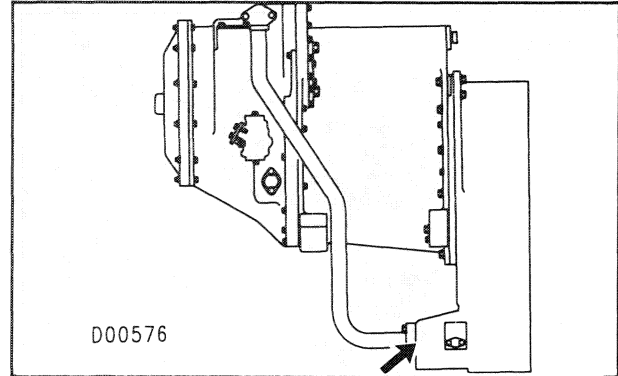

3. Remove the magnetic strainer cover located at the rear of the transmission transfer gear housing.
4. Remove the retainer, the tube and the screen from the housing.
5. Remove the tube and magnets from the screen.
6. Wash the tube and the screen in a clean, nonflammable solvent.
7. Clean the magnets with a cloth, a stiff bristle brush or pressure air.

---

#### NOTICE

Do not drop or rap the magnets against any hard objects. Replace any damaged magnets.

---

8. Clean the cover and inspect the seal. Replace the seal, if it is damaged.
9. Insert the tube and magnets in the screen.
10. Insert the screen, tube and magnets in the housing.
11. Install the cover. Tighten the cover bolts.
12. Clean and install the transmission drain plug.
13. Install the access cover on the transmission guard.

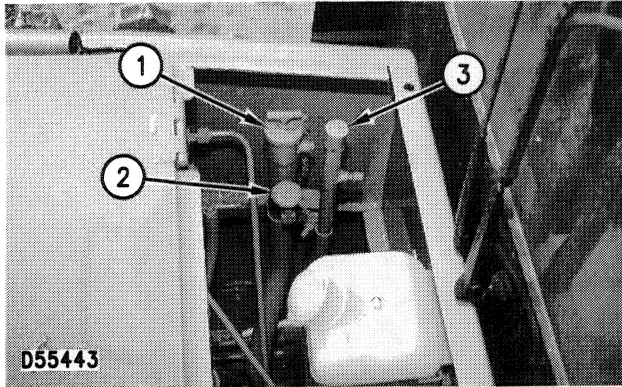

- 14.** Fill the transmission with oil through the fill tube (1). See the "Lubricant Viscosities and Refill Capacities" chart.
- 15.** Remove the transmission breather (2) located on the oil fill tube. Install a new transmission breather.
- 16.** Start the engine. Apply the service brake.
- 17.** Slowly operate the transmission controls to circulate the oil. Engage the transmission neutral lock.
- 18.** Maintain the oil level between the ADD and FULL marks on the dipstick (3). Add oil if necessary.
- 19.** Stop the engine.

## Drive Shaft Universal Joints

### Lubricate Fittings

Wipe all fittings before lubricating.

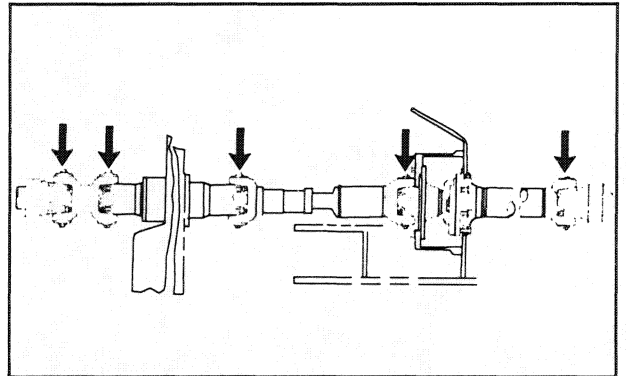

Lubricate five fittings on the drive shaft universal joints.

## Drive Shaft Support Bearing

### Lubricate Fitting

Wipe all fittings before lubricating.

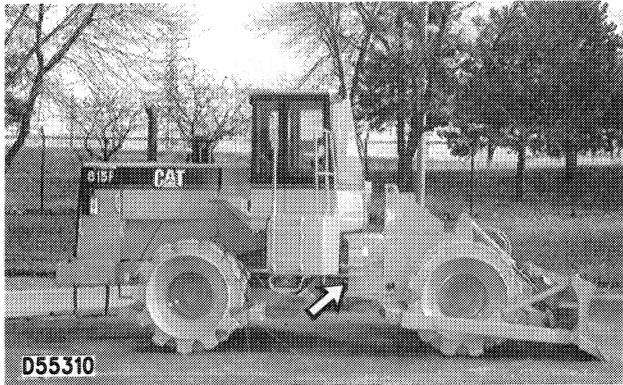

Lubricate one remote fitting for the drive shaft support bearing located on the right side of the machine.

## Frame Pivot Bearings

### Lubricate Fittings

Wipe all fittings before lubricating.

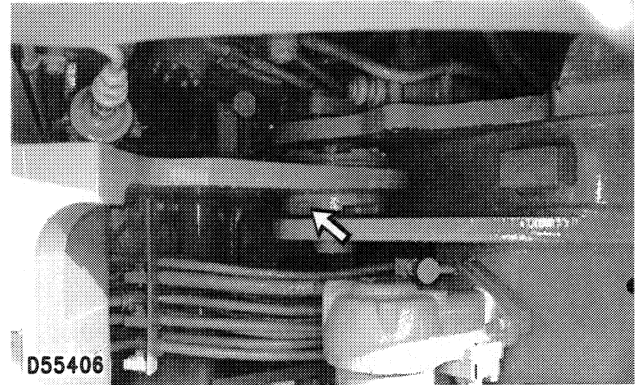

Lubricate one fitting in the upper pivot bearing located on the left side of the machine.

On some machines the fitting is on the right side of the machine.

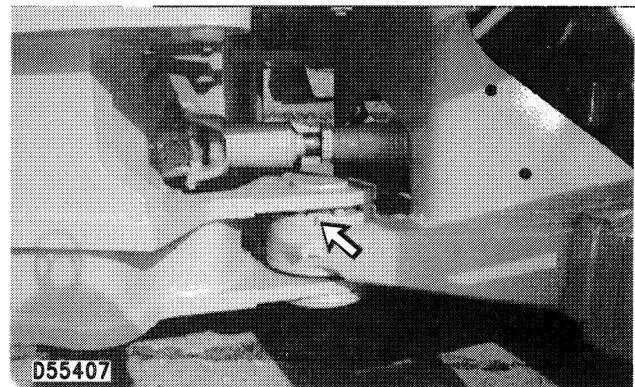

Lubricate one fitting in the lower pivot bearing.

Total of two fittings.

## Rollover Protective Structure (ROPS)

### Inspect ROPS/Tighten Bolts

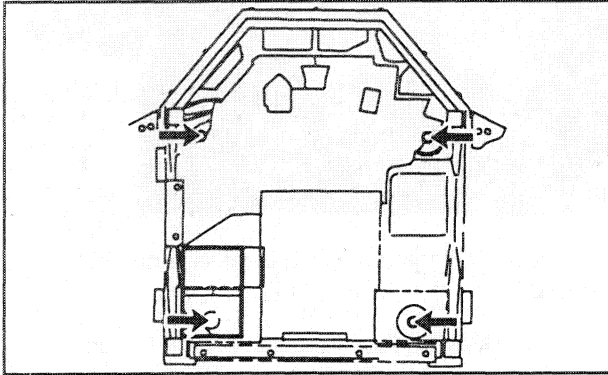

1. Remove access covers.
2. Inspect for any loose or damaged bolts. Replace damaged bolts or missing bolts with original equipment parts only. Tighten bolts to a torque of  $850 \pm 100 \text{ N}\cdot\text{m}$  ( $629 \pm 74 \text{ lb ft}$ ).

Note: For installation of mount to cab, lubricate with water or a rubber lubricant that does not have a petroleum base.

3. Replace ROPS mounting supports if the ROPS rattles or makes a noise when the machine is operated on a rough surface.
4. Install access covers.

Do not straighten or repair by welding reinforcement plates to the ROPS.

Contact your Caterpillar dealer for repair of cracks in welds, castings or any metal section on the ROPS.

## Cab Mounting Group

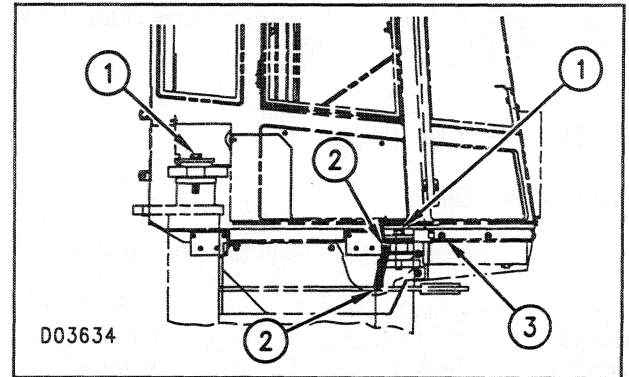

1. Torque for four bolts (1) -  $850 \pm 100 \text{ N}\cdot\text{m}$  ( $629 \pm 74 \text{ lb ft}$ ).
2. Torque for two nuts (2) -  $60 \pm 12 \text{ N}\cdot\text{m}$  ( $44 \pm 9 \text{ lb ft}$ ).
3. Torque for 11 bolts (3) -  $15 \pm 3 \text{ N}\cdot\text{m}$  ( $11 \pm 2 \text{ lb ft}$ ).

## Every 2000 Service Hours or 1 Year

*You must read and understand the warnings and instructions contained in the Safety section of this manual, before performing any operation or maintenance procedures.*

### Hydraulic Oil Tank

#### Change the Oil

Operate the machine long enough to warm the oil.

The machine should be level. The blade lowered to the ground with slight down pressure. Engage the transmission neutral lock and the parking/secondary brake. Stop the engine.

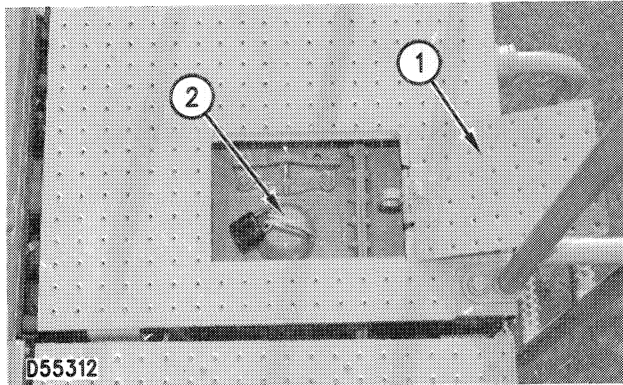

**1.** Open the access cover (1) located on the right of the machine in the operator's platform, and Remove the hydraulic oil tank filler cap (2) slowly to relieve the pressure..

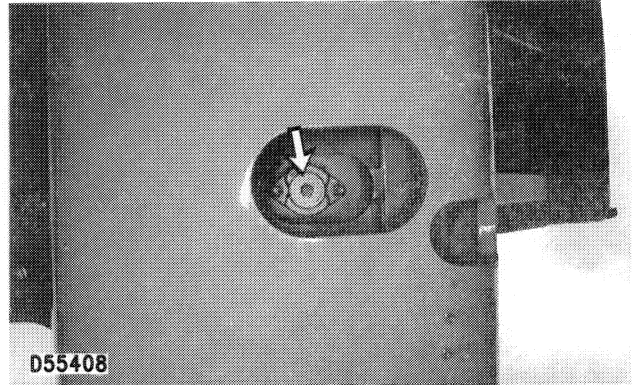

- 2.** Remove the tank drain plug located under the hydraulic tank.
- 3.** Install a 6B-3156 Pipe Nipple to unseat the drain valve. Allow the oil to drain into an approved container.
- 4.** Change the hydraulic filter. See "Hydraulic System" in the "Every 500 Service Hours or 3 Months" section.
- 5.** Remove the fill screen.
- 6.** Clean the fill screen in a clean nonflammable solvent. Shake or blow dry.
- 7.** Install the fill screen.
- 8.** Remove the drain pipe nipple.
- 9.** Clean the tank drain plug. Inspect the drain plug seal. Replace the seal if damaged.
- 10.** Install the drain plug.
- 11.** Fill the hydraulic oil tank. See "Lubricant Viscosities and Refill Capacities."
- 12.** Clean and hydraulic tank cap. Inspect the tank cap seal. Replace the seal if damaged.
- 13.** Install the hydraulic tank cap.
- 14.** Start and run the engine for a few minutes.

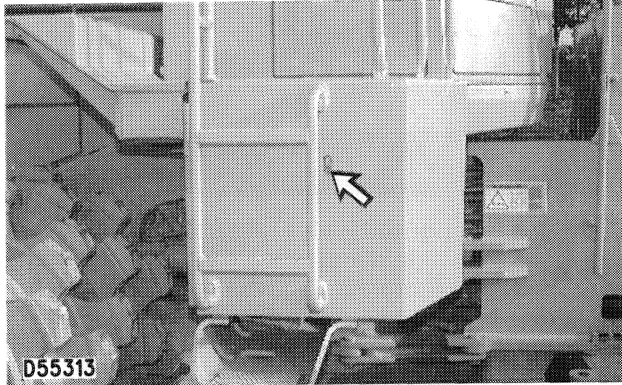

**15.** Maintain the oil level to the FULL mark in the sight gauge. Add oil if necessary.

**16.** Close the access cover. Stop the engine.

## Differentials

### Change the Oil

Wipe covers and surfaces around openings before checking or adding oil.

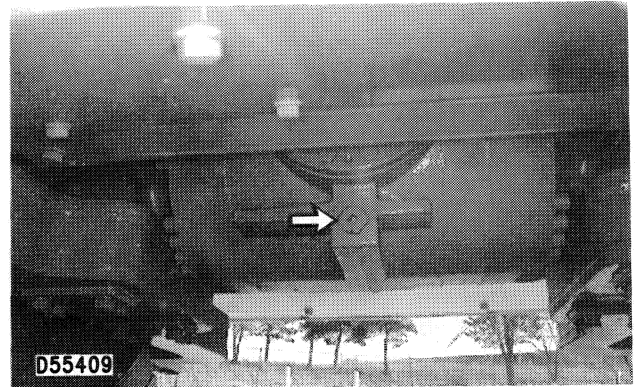

**1.** Remove the drain plugs for the front and rear differential and allow the oil to drain into a suitable container.

**2.** Clean and install the drain plugs.

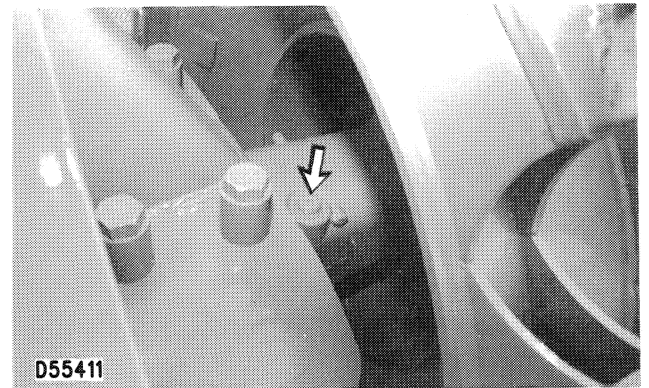

**3.** Remove the front and the rear differential fill plugs.

**4.** Fill and maintain the oil to the bottom of the fill plug. See the Lubricant Viscosities and Refill Capacities chart.

**5.** Clean and install the fill plugs.

**6.** Operate the machine a few minutes to allow the oil to flow thru the entire axles. Recheck the oil level. Remove the fill plugs and check the oil level. Add oil if necessary.

**7.** Clean and install the fill plugs.

## Engine Valve Lash and Injector Fuel Timing

### Adjust

Note: Have a qualified service person check and/or adjust valve lash and injector fuel timing. Special tools and training are required.

Refer to the Service Manual for the complete procedure.

Note: The correct fuel timing specification is given on the Engine Information Plate. Fuel timing specification may be different for engines with different applications and/or power ratings.

Refer to the Service Manual or your Caterpillar dealer for the complete adjustment procedure.

## Engine Valve Rotators

### Check

#### **WARNING**

**When inspecting the valve rotators, protective glasses or face shield and protective clothing must be worn, to prevent being burned by hot oil spray.**

1. Start the engine and run at Low Idle.

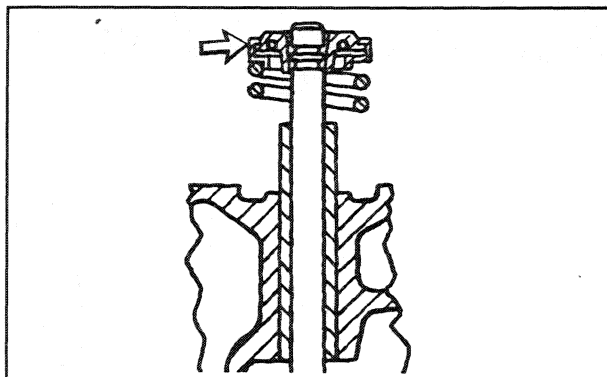

2. Watch the top surface on each valve rotator. Each valve rotator should turn slightly each time the valve closes.

If a valve fails to rotate, contact your Caterpillar dealer.



## Wet Disc Brakes

### Inspect Disc Wear

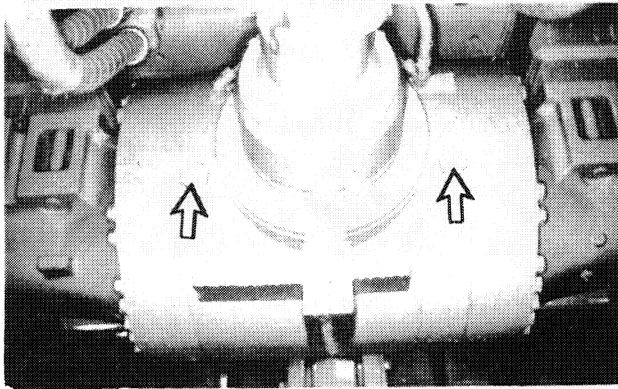

1. Remove the inspection ports on the front axle.

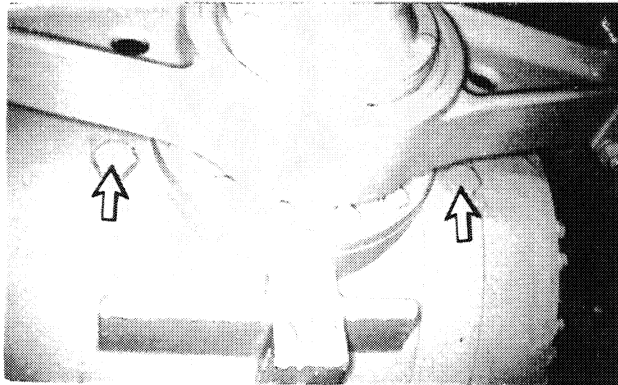

2. Remove the inspection ports on the rear axle.

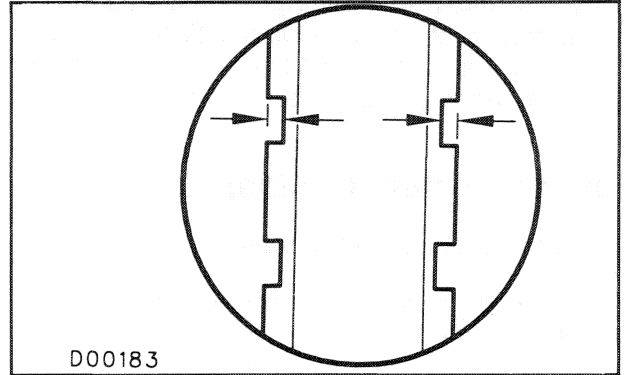

3. Measure the depth of the oil grooves on both sides of the brake disc. Refer to the following chart for the remaining brake disc life based on oil groove depth and disc thickness.

| Brake Disc Wear Information    |                   |                   |
|--------------------------------|-------------------|-------------------|
| Percent of Disc Life Remaining | Disc Thickness    | Disc Groove Depth |
| 100                            | 9.10 mm (.358 in) | 1.05 mm (.041 in) |
| 90                             | 8.96 mm (.353 in) | .98 mm (.038 in)  |
| 80                             | 8.81 mm (.347 in) | .90 mm (.036 in)  |
| 70                             | 8.67 mm (.341 in) | .83 mm (.033 in)  |
| 60                             | 8.52 mm (.335 in) | .76 mm (.030 in)  |
| 50                             | 8.38 mm (.330 in) | .69 mm (.027 in)  |
| 40                             | 8.23 mm (.324 in) | .61 mm (.024 in)  |
| 30                             | 8.09 mm (.318 in) | .54 mm (.021 in)  |
| 20                             | 7.94 mm (.313 in) | .47 mm (.018 in)  |
| 10                             | 7.80 mm (.307 in) | .39 mm (.015 in)  |
| 0                              | 7.65 mm (.301 in) | .32 mm (.013 in)  |

4. Install the inspection port plugs.

Consult your Caterpillar Dealer for brake disc replacement.

## Every 3000 Service Hours or 2 Years

*You must read and understand the warnings and instructions contained in the Safety section of this manual, before performing any operation or maintenance procedures.*

### Cooling System Coolant

#### Change Coolant/Clean System

NOTE: This procedure pertains to machines using standard antifreeze/coolant only.

---

#### NOTICE

Do not change the coolant until you read and understand the material in the "Cooling System Specifications" section.

---

Drain the coolant earlier whenever the coolant is dirty or foaming is observed.



The radiator access cover is located in the top of the hood at the right rear of the machine.

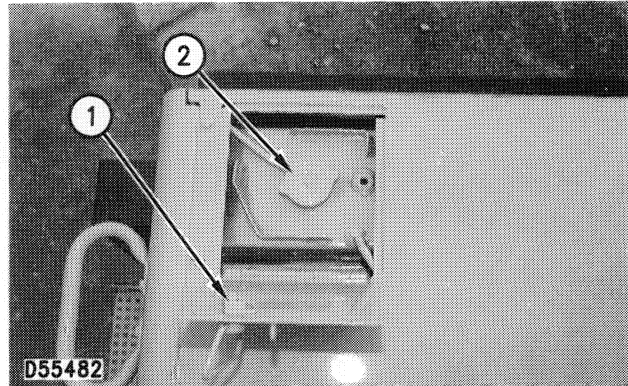

1. Open the access cover (1) and remove the radiator cap (2) slowly to relieve pressure.

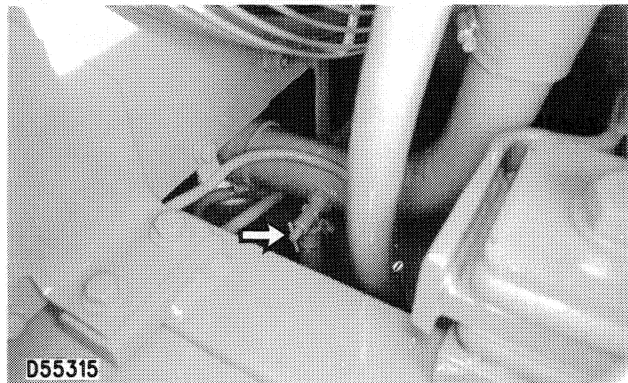

2. Open the engine access cover on the right side of the machine. Open the drain valve and allow the coolant to drain from the engine and the radiator.

3. Close the drain valve. Fill the system with clean water and a 6 to 10% concentration of cooling system cleaner.

4. Start and run the engine for 90 minutes. Stop the engine and drain the cleaning solution.

NOTE: The engine should be allowed to cool before flushing with cold water. Adding cold water to a hot engine could result in engine damage.

5. Flush the system with water, with the engine stopped, until the draining water is clear.

6. Close the drain valve.

**7.** Add the coolant solution. See "Cooling System Specifications" and "Lubricant Viscosities and Refill Capacities."

NOTE: Do not add supplemental coolant additive or change element at this time, unless you are not using Caterpillar Antifreeze which contains additive.

**9.** Start the engine and operate it with the radiator cap off, until the thermostat opens and the level stabilizes.

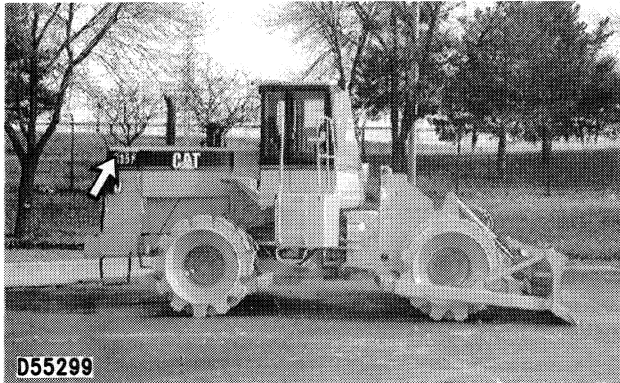

**10.** Maintain the coolant level in the sight sight gauge.

**11.** Install the cap.

**12.** Stop the engine.

### Clean Outside of Radiator Fins

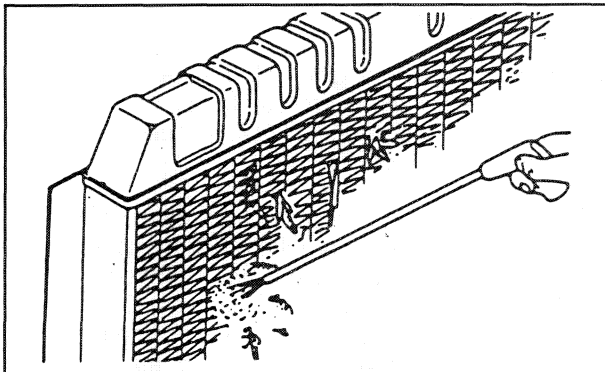

Compressed air is preferred, but high pressure water or steam can be used to remove dust, leaves and general debris from radiator fins.

## Cooling System Coolant (Long Life Coolant Antifreeze)

### Add "Extender"

NOTE: This procedure pertains to machines using Long Life Coolant Antifreeze only.

Extender should only be added to LLCA after 3,000 Service Hours or two years, whichever comes first. Add extender to the coolant to obtain a  $2.2 \pm 0.3\%$  extender concentration.

1. Stop the engine and allow to cool.
2. Remove the radiator cap slowly to relieve pressure.
3. The cooling system should be treated with .97 L (1 qt) of Extender for every 46 L (12 US gal) of cooling system capacity.
4. Install the radiator cap.

For more Extender information, refer to the Cooling System Specifications LLCA Extender topic in this manual.

## Every 6000 Service Hours or 4 Years

*You must read and understand the warnings and instructions contained in the Safety section of this manual, before performing any operation or maintenance procedures.*

### Cooling System Coolant (Extended Life Coolant)

#### Clean/Flush/Change coolant

NOTE: This procedure pertains to machines using Extended Life Coolant only.

---

#### NOTICE

Do not change the coolant until you read and understand the material in the Safety and Cooling System Specifications sections of this publications.

---

Caterpillar Extended Life Coolant should be replaced every 6,000 Service Hours or 4 Years, whichever comes first. Only clean water is needed to clean and flush the cooling system when ELC is drained and replaced.

#### Drain

1. Stop the engine and allow to cool. Loosen the coolant filler cap slowly to relieve pressure and remove the cap.
2. Open the drain valve. Remove the block and oil cooler drain plugs. Remove the drain plug from the bottom of the water pump housing. Allow the coolant to drain into an approved container.

---

#### NOTICE

Dispose of used engine coolant properly or recycle. Various methods have been proposed to reclaim used coolant for reuse in engine cooling systems. The full distillation procedure is the only method acceptable by Caterpillar to reclaim the used coolant. Contact your Caterpillar dealer for information regarding disposal and recycling of used coolant.

---

For information regarding disposal and recycling of used coolant, contact:

Caterpillar Service Technology Group:

Outside Illinois: 1-800-542-TOOL

Inside Illinois: 1-800-541-TOOL

Canada: 1-800-523-TOOL

#### Flush

3. Flush the cooling system with clean water to remove any debris.
4. Clean and install all drain plugs and/or close the drain valve(s).
5. Close the drain valve. Fill the system with clean water. Install the filler cap. Operate the engine until warm, 49 to 66°C (120 to 150°F).
6. Stop the engine and allow the engine to cool. Loosen the coolant filler cap slowly to relieve any pressure and remove the cap. Remove the cooling system drain plug(s) or open the drain valve. Allow the water to drain. Flush the cooling system with clean water until the draining water is clear.

7. Install the cooling system drain plug(s) or close the drain valve.

#### Fill

8. Fill the cooling system with ELC. Refer to the refill capacities chart in this manual for the amount of ELC needed to refill your system.
9. Start and run the engine with the filler cap off. Allow the ELC to warm, the thermostat to open and the coolant level to stabilize. Add ELC if necessary to bring the coolant to the proper level.
10. Check the condition of the filler cap gasket. If the gasket is damaged, discard the old filler cap and install a new filler cap. If the gasket is not damaged, use a 9S-8140 Service Tool (available from your Caterpillar dealer) to pressure test the filler cap. The correct filler cap pressure is stamped on the face of the filler cap. If the filler cap does not hold the correct pressure, install a new filler cap.
11. Start the engine and inspect for coolant leaks and proper operating temperature.

## Literature Reference Materials

### Caterpillar Reference Material

The following literature can be obtained through any Caterpillar dealer.

SEBD0518, Know Your Cooling System

SEBD0970, Coolant and Your Engine

SEBD0717, Diesel Fuels and Your Engine

SEHS9031, Storage Procedure for Caterpillar Products

SEBU5898, Cold Weather Recommendations Operation & Maintenance Manual

SEBD0640, Oil and Your Engine

SEBU6250, Caterpillar Machine Lubricant Recommendations

SEBU5407, Safety Manual

SEBU6981, Warranty Information for Certified Engines

SENR1305, Service Manual

Operation & Maintenance Manuals are available in other languages. Contact any Caterpillar dealer for a manual.

### Machine Decommissioning and Disposal

Machine decommissioning and disposal will vary with local regulations. Contact the nearest Caterpillar dealer for additional information.

### Additional Reference Material

ASTM D2896 TBN Measurements (Can normally be obtained from your local technological society, library or college.)

SAE J313 Diesel Fuels (Found in the SAE handbook or can be obtained from any local library, college or technological society.)

SAE J754 Nomenclature (Normally found in the SAE handbook.)

SAE J183 Classification (Normally found in the SAE handbook.)

### Warranty Information

The engine in this machine may be certified and covered by an emissions warranty. A detailed explanation of the emissions warranty, applicable to certified engines, is found in SEBU6981, "Emissions Control Warranty Information". The engine is certified if it has a special certification label. A Caterpillar dealer can also inform you if the engine is certified.

# Index

## A

|   |     |
|---|-----|
| Accelerator Pedal .....                       | 33  |
| Additional Reference Material .....           | 132 |
| After Starting the Engine .....               | 43  |
| After-Market Oil Additives .....              | 80  |
| Air Conditioner (If Equipped) .....           | 112 |
| Test Operation - Adjust Belt .....            | 112 |
| Alternate Exit .....                          | 31  |
| Attachment Control Lever Lock .....           | 37  |
| Attachment Controls .....                     | 36  |
| Attachment Lowering With Engine Stopped ..... | 59  |

## B

|   |     |
|---|-----|
| Backup Alarm .....  | 26  |
| Backup Alarm .....  | 102 |
| Test .....  | 102 |
| Batteries .....   | 114 |
| Battery Recycling .....   | 115 |
| Check Electrolyte Level .....                                       | 114 |
| Replacement of Battery, Battery Cable or<br>Disconnect Switch ..... | 115 |
| Battery Disconnect Switch .....                                     | 18  |
| Before Operating the Machine .....                                  | 13  |
| Before Starting the Engine .....                                    | 13  |
| Before Starting the Engine .....                                    | 38  |
| Brake Pedals .....  | 32  |
| Brakes .....  | 109 |
| Test Brake Accumulator .....  | 110 |
| Test Parking Brake Holding Ability .....                            | 109 |
| Test Service Brake Holding Ability .....                            | 109 |
| Brakes, Indicators and Gauges .....                                 | 101 |
| Test for Proper Function .....                                      | 101 |
| Bulldozer Blade Control Lever .....                                 | 36  |
| Bulldozer Blade Tilt Lever .....                                    | 36  |
| Bulldozer Blade Tip Lever .....                                     | 37  |
| Bulldozer Cylinder Rod Bearing .....                                | 106 |
| Lubricate the Fitting .....   | 106 |
| Bulldozer Cylinder Trunnion Bearing .....                           | 106 |
| Lubricate the Fittings .....  | 106 |
| Bulldozer Stabilizer .....  | 105 |
| Lubricate the Fitting .....   | 105 |
| Burn Prevention .....   | 9   |

## C

|  |     |
|--|-----|
| Cab Air System .....                   | 103 |
| Clean Filters .....                    | 103 |
| California .....                       | 3   |
| Caterpillar Lubricating Grease .....   | 81  |
| Caterpillar Specialty Lubricants ..... | 81  |
| Gear Oil (GO) .....                    | 82  |
| Hydraulic Oil .....                    | 81  |

|   |     |
|---|-----|
| Caterpillar Monitoring System .....                                   | 20  |
| Caterpillar Monitoring System Warning Categories ...                  | 22  |
| Caterpillar Reference Material .....                                  | 132 |
| Caterpillar Transmission/Drive Train Oil (TDTO)(TO-<br>4) .....       | 80  |
| Caterpillar's Extended Life Coolant .....                             | 66  |
| Extender .....  | 66  |
| Extended Life Coolant Cooling System<br>Maintenance .....             | 67  |
| Chopper Blades (816F) .....   | 94  |
| Inspect/Replace .....   | 94  |
| Cleaner Bar (815F) .....  | 92  |
| Measure and Adjust .....  | 92  |
| Replace Scraper Tips .....  | 93  |
| To Adjust: .....  | 93  |
| Commercial Diesel Engine Oils .....                                   | 77  |
| Compacting - (Typical Example) .....                                  | 49  |
| Conventional Antifreeze/Coolant .....                                 | 68  |
| Acceptable Antifreeze/Coolant .....                                   | 69  |
| Conventional Cooling System Maintenance .....                         | 72  |
| Permitted-Water/Supplemental Coolant Additive ..                      | 71  |
| Recommended - Caterpillar's Diesel Engine<br>Antifreeze/Coolant ..... | 68  |
| Supplemental Coolant Additive .....                                   | 70  |
| Cooling System .....  | 97  |
| Look at the Coolant Level .....                                       | 97  |
| Cooling System .....  | 108 |
| Add Supplemental Coolant Additive/Replace<br>Element .....            | 108 |
| Cooling System Coolant (Extended Life Coolant) ...                    | 139 |
| Add "Extender" .....  | 139 |
| Cooling System Coolant (Extended Life Coolant<br>Antifreeze) .....    | 140 |
| Clean/Flush/Change coolant .....                                      | 140 |
| Cooling System Coolant .....  | 130 |
| Change Coolant/Clean System .....                                     | 130 |
| Clean Outside of Radiator Fins .....                                  | 131 |
| Cooling System Specifications .....                                   | 64  |
| Crushing or Cutting Prevention .....                                  | 9   |
| Cutting Edge and End Bits .....                                       | 91  |
| Change or Replace .....   | 91  |

## D

|                                    |     |
|------------------------------------|-----|
| Differentials .....                | 127 |
| Change the Oil .....               | 127 |
| Digital Display Window .....       | 24  |
| Ditching - (Typical Example) ..... | 47  |
| Drive Shaft Spline .....           | 111 |
| Lubricate Fitting .....            | 111 |
| Drive Shaft Support Bearing .....  | 124 |
| Lubricate Fitting .....            | 124 |
| Drive Shaft Universal Joints ..... | 123 |
| Lubricate Fittings .....           | 123 |

**E**

|  |     |
|--|-----|
| Engine Air Intake System .....   | 85  |
| Change the Secondary Element .....   | 86  |
| Clean the Air Intake .....   | 85  |
| Cleaning Primary Elements .....  | 87  |
| Service the Filter Elements .....  | 85  |
| Service the Primary Element .....  | 85  |
| Engine Crankcase Breather .....  | 108 |
| Clean Breather .....   | 108 |
| Engine Lubricant Specifications .....  | 77  |
| Engine Lubricant Viscosity Recommendations .....                                 | 79  |
| Engine Oil .....   | 95  |
| Check the Oil Level .....  | 95  |
| Engine Oil and Filter .....  | 107 |
| Change the Oil and Filter .....  | 107 |
| Engine Start Switch Key .....  | 19  |
| Engine Starting .....  | 13  |
| Engine Starting .....  | 40  |
| Engine Starting Above 0°C (+32°F) .....  | 40  |
| Engine Starting Below 0°C (+32°F) (If Equipped<br>with Ether Starting Aid) ..... | 40  |
| Engine Starting with Auxiliary Start Receptacles .....                           | 42  |
| Engine Starting with Jump Start Cables .....                                     | 41  |
| Engine Stopping .....  | 53  |
| Engine Valve Lash and Injector Fuel Timing .....                                 | 128 |
| Adjust .....   | 128 |
| Engine Valve Rotators .....  | 128 |
| Check .....  | 128 |
| Ether Starting Aid (If Equipped) .....   | 87  |
| Installing the Cylinder .....  | 87  |
| Ether Starting Aid .....   | 19  |
| Every 10 Service Hours or Daily .....  | 95  |
| Every 50 Service Hours or Weekly .....   | 103 |
| Every 100 Service Hours or 2 weeks .....   | 104 |
| Every 250 Service Hours or Monthly .....   | 107 |
| Every 500 Service Hours or 3 Months .....  | 116 |
| Every 1000 Service Hours or 6 Months .....                                       | 122 |
| Every 2000 Service Hours or 1 Year .....   | 126 |
| Every 3000 Service Hours or 2 Years .....  | 130 |

**F**

|                                |     |
|--------------------------------|-----|
| Fan and Alternator Belts ..... | 113 |
| Inspect-Adjust-Replace .....   | 113 |
| Fan Bearing .....              | 111 |
| Lubricate Fitting .....        | 111 |

|  |     |
|--|-----|
| Filter Inspection .....                  | 94  |
| Inspect Used Oil Filter for Debris ..... | 94  |
| Fire or Explosion Prevention .....       | 10  |
| Foreword .....                           | 2   |
| Frame Pivot Bearings .....               | 124 |
| Lubricate Fittings .....                 | 124 |
| Fuel Recommendations .....               | 73  |
| Fuel Specifications .....                | 73  |
| Fuel System .....                        | 118 |
| Change Secondary Fuel Filter .....       | 119 |
| Clean and Change Filters .....           | 118 |
| Priming the Fuel Filters .....           | 119 |
| Priming the Fuel System .....            | 120 |
| Wash the Primary Filter Element .....    | 118 |
| Fuel Tank .....                          | 98  |
| Drain the Water and Sediment .....       | 98  |
| Fuel Tank Cap and Fill Screen .....      | 120 |
| Clean .....                              | 120 |
| Fuses and Circuit Breakers .....         | 88  |
| Replace Fuses .....                      | 88  |
| Reset Circuit Breakers .....             | 89  |

**G**

|                                   |    |
|-----------------------------------|----|
| Gauges .....                      | 24 |
| General Coolant Information ..... | 64 |
| Additives .....                   | 64 |
| Coolant Recommendations .....     | 65 |
| Glycol .....                      | 64 |
| Water .....                       | 64 |
| General Hazard Information .....  | 7  |
| General Information .....         | 77 |
| General Section .....             | 15 |

**H**

|  |     |
|--|-----|
| Heating and Air Conditioning Controls (If Equipped) .. | 27  |
| Horn .....   | 26  |
| Hydraulic Oil .....                                    | 96  |
| Check the Oil Level .....                              | 96  |
| Hydraulic Oil Tank .....                               | 126 |
| Change the Oil .....                                   | 126 |
| Hydraulic System .....                                 | 117 |
| Change the Filters .....                               | 117 |

**I**

|                                    |   |
|------------------------------------|---|
| Important Safety Information ..... | 4 |
| Information Section .....          | 1 |

|  |     |  |     |
|--|-----|--|-----|
| <b>L</b>   |     | <b>R</b>   |     |
| Landfill Compacting – (Typical Example) .....            | 50  | Re-Refined Base Stock Oils .....                     | 79  |
| Leaving the Machine .....                                | 54  | Rear Axle Trunnion .....                             | 104 |
| Light Switches .....                                     | 25  | Lubricate Fittings .....                             | 104 |
| Lighter .....  | 31  | Rollover Protective Structure (ROPS) .....           | 125 |
| Literature Information .....                             | 2   | Cab Mounting Group .....                             | 125 |
| Literature Reference Materials .....                     | 132 | Inspect ROPS/Tighten Bolts .....                     | 125 |
| Literature Reference Section .....                       | 132 |  |     |
| Lubricant Specifications .....                           | 77  | <b>S</b>   |     |
| Lubricant Viscosities .....                              | 83  | Safety .....   | 2   |
| Lubricant Viscosities and Refill Capacities .....        | 83  | Safety .....   | 5   |
|  |     | Safety Section .....                                 | 4   |
| <b>M</b>   |     | Scheduled Oil Sampling (S•O•S) .....                 | 76  |
| Machine Controls .....                                   | 32  | Seat .....   | 28  |
| Machine Decommissioning and Disposal .....               | 132 | Seat and Seat Belt Checks .....                      | 39  |
| Machine Description .....                                | 3   | Seat Belt .....                                      | 29  |
| Machine Lifting/Tie-down Information .....               | 56  | Seat Belt .....                                      | 101 |
| Machine Operation .....                                  | 14  | Inspect for Wear or Damage .....                     | 101 |
| Machine Operation .....                                  | 44  | Side Hill Cut – (Typical Example) .....              | 49  |
| Machine Parking .....                                    | 14  | Sound and Vibration Information .....                | 14  |
| Machine Parking .....                                    | 53  | Specifications and Model Views .....                 | 15  |
| Machine Rooding .....                                    | 55  | Steering Column Tilting .....                        | 35  |
| Machine Shipping .....                                   | 55  | Steering Controls .....                              | 34  |
| Machine Stopping .....                                   | 53  | Steering Cylinder Bearings .....                     | 104 |
| Machine Walk-Around Inspection .....                     | 38  | Lubricate Fittings .....                             | 104 |
| Maintenance .....  | 2   | Straight Dozing – (Typical Example) .....            | 46  |
| Maintenance Intervals .....                              | 84  | Synthetic Base Stock Oils .....                      | 79  |
| Maintenance Section .....                                | 60  | S•O•S Analysis .....                                 | 76  |
| Manual Release of Parking Brake .....                    | 59  |  |     |
| Mirror .....   | 30  | <b>T</b>   |     |
| Monitoring Systems and Cab Features .....                | 18  | Tamping Tips (815F) .....                            | 92  |
| Mounting and Dismounting .....                           | 12  | Inspect or Replace .....                             | 92  |
| Mounting The Machine .....                               | 38  | Tire Inflation Information .....                     | 60  |
|  |     | Tire Inflation Pressures Adjustment .....            | 61  |
| <b>O</b>   |     | Tire Inflation with Nitrogen (N <sub>2</sub> ) ..... | 60  |
| Operating Techniques .....                               | 46  | Tire Shipping Pressure .....                         | 61  |
| Operation .....  | 2   | Torque Specifications .....                          | 62  |
| Operation Section .....                                  | 18  | Torques for Constant Torque Type Hose Clamps .....   | 62  |
|  |     | Torques for Ground Engaging Tool Bolts .....         | 62  |
| <b>P</b>   |     | Torques for Metric Fasteners .....                   | 63  |
| Parking Brake .....                                      | 32  | Torques for Standard Fasteners .....                 | 62  |
| Parking Brake System .....                               | 45  | Torques for Standard Hose Clamps – Worm Drive .....  | 62  |
| Product Identification, Serial Number and CE Plate ..... |     | Band Type .....                                      | 62  |
| Locations .....  | 16  | Total Base Number (TBN) and Fuel Sulfur Levels ..... |     |
| Push Loading – (Typical Example) .....                   | 52  | For Caterpillar Diesel Engines .....                 | 78  |
|  |     | Towing Information .....                             | 57  |
|  |     | Transmission Direction and Speed Control .....       | 33  |
|  |     | Transmission Neutral Lock .....                      | 33  |
|  |     | Transmission Oil .....                               | 96  |
|  |     | Check the Oil Level .....                            | 96  |



Transmission Oil ..... 122  
    Change the Oil ..... 122  
Transmission Oil Filter ..... 116  
    Change Filter ..... 116  
Transmission Up/Down Shift Control ..... 34  
Transportation Information ..... 55  
Tree or Brush Removal - (Typical Example) ..... 48

**W**

Walk-Around Inspection ..... 99  
    Cleaning Plastic Windows ..... 100  
    Cleaning Windows ..... 100  
    Inspect Machine ..... 99  
    Window Cleaning Methods ..... 100  
Warning Signs ..... 5  
Warranty Information ..... 132  
Wet Disc Brakes ..... 129  
    Inspect Disc Wear ..... 129  
When Required ..... 85  
Window Cleaning ..... 31  
Windshield Wiper/Washer ..... 26  
Windshield Wipers and Washer ..... 90  
    Fill Washer Bottle ..... 90  
    Inspect/Replace ..... 90



•

•



•

•



APPENDIX A

ADDDITIONAL AUTHORIZATION LIST (AAL)  
FOR  
HIGH SPEED, SELF-PROPELLED, COMPACTOR

---

| NSN              | NOMAMCLATURE       |
|------------------|--------------------|
| 4210-01-424-2215 | Extinguisher, Fire |

---



**APPENDIX B**  
**INTERIM SUPPORT ITEMS LIST (ISIL)**  
**FOR**  
**HIGH SPEED, SELF-PROPELLED, COMPACTOR**

| NSN                               | NOMENCLATURE                          | QUANTITY |
|-----------------------------------|---------------------------------------|----------|
| 2940-00-029-0388 <i>1R0739</i>    | Oil Filter                            | 2        |
| 2940-01-438-4900 <i>6I 2503</i>   | Primary Air Filter Element            | 1        |
| 2940-01-438-4901 <i>6I 2504</i>   | Secondary Air Filter Element          | 1        |
| 2910-00-740-3593 <i>1R0719 or</i> | Transmission Oil Filter <i>2M3943</i> | 1        |
| 5330-01-021-9880 <i>288439</i>    | Transmission Filter Seal              | 1        |
| 2940-01-437-6111 <i>1R0722</i>    | Hydraulic Oil Filter Element          | 1        |
| 5330-00-580-1216 <i>2H 3931</i>   | Hydraulic Filter Housing Seal         | 1        |
| 3030-01-442-2000 <i>2W 8951</i>   | V-Belt                                | 1        |
| 2910-01-346-6362 <i>1R1740</i>    | Fuel Filter                           | 2        |
| 5330-00-585-4284 <i>8H 2778</i>   | Fuel Filter Gasket                    | 2        |



**APPENDIX C**  
**APPROVED FUELS, LUBRICANTS, GREASES, AND OILS**  
**FOR**  
**HIGH SPEED, SELF-PROPELLED, COMPACTOR**

| <u>NSN</u>   | <u>NOMENCLATURE</u>   | <u>UM/UI</u>                                  |
|--|---|---|
| 9150-01-178-4726<br>9150-00-188-9858<br>9150-00-189-6729 | Oil, Lubricating, ICE, Tactical Service (MIL-PRF-2104G) (OE/HDO-30) (12 F to 120 F) (ENGINE)            | 1 Quart Can<br>5 Gallon Can<br>55 Gallon Drum |
| 9150-00-402-4478<br>9150-00-402-2372<br>9150-00-491-7197 | Oil, Lubricating, ICE, Arctic (MIL-L-46167) (OEA) (-50 F to 35 F) (ENGINE - COLD WEATHER)               | 1 Quart Can<br>5 Gallon Can<br>55 Gallon Drum |
| 9150-01-035-5392<br>9150-01-035-5393<br>9150-01-035-5394 | Oil, Lubricating, Gear, Multipurpose (MIL-L-2105) (GO-80/90) (-10 F to 120 F) (DIFFERENTIAL)            | 1 Quart Can<br>5 Gallon Can<br>55 Gallon Drum |
| 9150-01-035-5390<br>9150-01-048-4593<br>9150-01-035-5391 | Oil, Lubricating, Gear, Multipurpose (MIL-L-2105) (GO-75) (-50 F to 45 F) (DIFFERENTIAL - COLD WEATHER) | 1 Quart Can<br>5 Gallon Can<br>55 Gallon Drum |

# TM 5-3805-380-10

Oil, Lubricating, Internal  
Combustion Engine (ICE), Tactical  
Service (MIL-L-2104) (OE/HDO-10)  
(-15 F to 120 F) (HYDRAULIC)

|                  |                |
|------------------|----------------|
| 9150-00-189-6727 | 1 Quart Can    |
| 9150-00-186-6668 | 5 Gallon Can   |
| 9150-00-191-2772 | 55 Gallon Drum |

Oil, Lubricating, ICE, Arctic  
(MIL-L-46167) (OEA)  
(-50 F to 120 F)  
(HYDRAULIC - COLD WEATHER)

|                  |                |
|------------------|----------------|
| 9150-00-402-4478 | 1 Quart Can    |
| 9150-00-402-2372 | 5 Gallon Can   |
| 9150-00-491-7197 | 55 Gallon Drum |

TRANSMISSION  
(35 F to 95 F)

Caterpillar Oil, Part Number (11083) 2P9869, MUST be used when adding oil/changing the oil in the transmission. DO NOT use the Military Equivalent (MIL-L-2104) in the transmission. It will cause damage to the transmission, which will not be covered under the commercial warranty.

Oil, Lubricating, ICE, Arctic  
(MIL-L-46167) (OEA)  
(-50 F to 120 F)  
(TRANSMISSION - COLD WEATHER)

|                  |                |
|------------------|----------------|
| 9150-00-402-4478 | 1 Quart Can    |
| 9150-00-402-2372 | 5 Gallon Can   |
| 9150-00-491-7197 | 55 Gallon Drum |

Grease, Automotive, and  
Artillery (MIL-G-10924)  
(-50 F to 120 F)

|                  |                 |
|------------------|-----------------|
| 9150-01-197-7688 | 2.25 Ounce Tube |
| 9150-01-197-7690 | 1.75 Pound Can  |
| 9150-01-197-7689 | 6.5 Pound Can   |
| 9150-01-197-7692 | 35 Pound Can    |

Coolant, Antifreeze, Ethylene



Glycol, Inhibited, Heavy Duty  
(MIL-A-46153)

6850-00-181-7933  
6850-00-181-7940

5 Gallon Can  
55 Gallon Drum

Fuel, Aviation, Turbine, JP-8,  
NATO F-34 (MIL-T-83133)

9130-01-305-5597

Gallon



**OPERATOR PREVENTIVE MAINTENANCE CHECKS AND SERVICES  
FOR  
HIGH SPEED, SELF-PROPELLED, COMPACTOR**

**APPENDIX D**

**PREVENTIVE MAINTENANCE CHECKS AND SERVICES (PMCS)**

**D-1 GENERAL**

Preventive Maintenance Checks and Services (PMCS) mean systematically caring, inspecting, and servicing equipment to keep it in good condition and to prevent breakdowns. As the compactor operator, your mission is to:

**NOTE**

**PMCS intervals are identified by both calendar intervals (daily, weekly, monthly, etc) and by hours shown on the service hour meter. Perform the required service at the interval that occurs first.**

**NOTE**

**Designated intervals are performed under usual operating conditions. PMCS intervals must be performed more frequently when operating under unusual conditions.**

**NOTE**

**If the compactor has not been used in the past 7 days, all DURING, AFTER, and WEEKLY tasks must be completed with the BEFORE tasks.**

- a. Be sure to do PMCS each time you operate the compactor. Always do PMCS in the same order, so it gets to be a habit. With some practice, you'll quickly spot anything wrong.
- b. Do BEFORE PMCS just before operating the compactor. Pay attention to WARNINGS, CAUTIONS, and NOTES.
- c. Do DURING PMCS upon start up of the vehicle and while operating the compactor or any of its component systems. Continuously monitor your vehicle system during operation. Pay attention to WARNINGS, CAUTIONS, and NOTES.
- d. Do AFTER PMCS right after operating the compactor. Pay attention to WARNINGS, CAUTIONS, and NOTES.
- e. Do WEEKLY PMCS once every 7 days or 50 hours of service.
- f. Do MONTHLY PMCS once every 30 days or 250 hours of service.
- g. Use DA Form 2404 (Equipment Inspection and Maintenance Worksheet) to record any faults discovered before, during or after operation that cannot be immediately fixed. Do not record faults that are immediately fixed.
- h. Be prepared to assist organizational maintenance during lubrication of the compactor, and to perform all other organizational maintenance directed services.

**OPERATOR PREVENTIVE MAINTENANCE CHECKS AND SERVICES  
FOR  
HIGH SPEED, SELF-PROPELLED, COMPACTOR**

**D-2 CLEANING**

Equipment must be maintained in as clean a condition as available cleaning equipment, material, and operating conditions permit.

**WARNING**

**DO NOT** use diesel fuel, gasoline, or benzene (benzol) for cleaning.

Dry cleaning solvent P-D-680 is toxic and flammable. Wear protective goggles and gloves and use in a well-ventilated area. Avoid contact with skin, eyes, and clothes and **DO NOT** breathe vapors. Do not use near open flame or excessive heat. Never smoke around solvent. The flash point of type III solvent is 200 degrees F. (93degrees C.)

If you become dizzy while using dry cleaning solvent, get fresh air immediately and get medical aid. If solvent gets in your eye, immediately flush the eye with water and get medical aid.

**CAUTION**

Steam cleaning and pressure air cleaning can cause personal injury, therefore, wear protective face shield, clothing, and shoes.

The maximum air pressure must be below 205KPa (30psi) for cleaning purposes.

Accumulated grease and oil on a machine is a fire hazard. Remove this debris by steam cleaning or high-pressure wash when a significant quantity of oil/grease accumulates on the equipment.

**D-3 LUBRICANTS.**

Caterpillar oil, part number (11083) 2P9869, **MUST** be used when adding or changing oil in the transmission. **DO NOT** use Military Equivalent (MIL-L-2104) in the transmission. It will cause damage to the transmission, which will not be covered under the commercial warranty. All other lubrication of the compactor shall be in accordance with MIL-PRF-2104-G specifications.

**D-4 FLUID LEAKAGE DEFINITIONS FOR OPERATOR PMCS.**

Wetness around seals, gaskets, fittings, or connections indicates leakage. A stain also denotes leakage. If a fitting or connector is loose, broken or defective report it. Use the following guidelines:

**OPERATOR PREVENTIVE MAINTENANCE CHECKS AND SERVICES  
FOR  
HIGH SPEED, SELF-PROPELLED, COMPACTOR**

**CAUTION**

Excluding fuel leaks, operation is allowable with class I or class II leakage. **WHEN IN DOUBT, NOTIFY YOUR SUPERVISOR.** When operating with class I or II leaks, check fluid levels more frequently. Class III leaks must be reported immediately to your supervisor or unit maintenance. Failure to do so will result in damage to the equipment an/or components.

- a. **Class I-** Seepage of fluid (as indicated by wetness or discoloration) not great enough to form drops
- b. **Class II-** Leakage of fluid great enough to form drops but not great enough to cause drops to drip from the item being checked/inspected.
- c. **Class III-** Leakage of fluid great enough to form drops that fall from the item being checked/inspected.

**D-5 PMCS PROCEDURES.**

- a. Preventive Maintenance Checks and Services lists inspection and care required to keep the compactor in good operating condition. This table is set up so you can do BEFORE and AFTER PMCS while walking around the compactor.
- b. B. The "Item NO" column provides number for each check or service. Use these numbers in the "TM ITEM NO." column on DA Form 2404 when recording faults that your don't immediately fix.
- c. The "Interval" column tells when to do a certain check or service.
- d. The "Item to Check/Service" column lists the item to check or service
- e. The "Procedure" column tells how to do the check or service. Carefully follow these instructions. If tools aren't available, or directed by procedure, notify your supervisor.
- f. The "Not fully mission capable If" column tells you when you can't use the compactor. Don't use the compactor if any of these conditions exist.
- g. If anything looks wrong and you can't fix it, write in on a DA Form 2404 and IMMEDIATELY notify your supervisor or unit maintenance.
- h. When doing PMCS, you will need dry, clean wiping cloths. Following are the checks that are common to the entire compactor:

**OPERATOR PREVENTIVE MAINTENANCE CHECKS AND SERVICES  
FOR  
HIGH SPEED, SELF-PROPELLED, COMPACTOR**

**WARNING**

- **DO NOT** use diesel fuel, gasoline, or benzene (benzol) for cleaning.
  - Dry cleaning solvent P-D-680 is toxic and flammable. Wear protective goggles and gloves and use in a well-ventilated area. Avoid contact with skin, eyes, and clothes and **DO NOT** breathe vapors. Do not use near open flame or excessive heat. Never smoke around solvent. The flash point of type III solvent is 200 degrees F. (93degrees C.)
  - If you become dizzy while using dry cleaning solvent, get fresh air immediately and get medical aid. If solvent gets in your eye, immediately flush the eye with water and get medical aid.
- (1) **Keep it Clean.** Dirt, grease, oil, and debris only get in the way and may cover up a serious problem. Clean as you work. Use cleaning solvent on all greasy or oily metal surfaces. Use soap and water when you clean rubber or plastic material.
  - (2) **Rust and Corrosion.** Check compactor body and frame for rust and corrosion. If any bare metal or corrosion exists, clean and apply a thin coat of light grade lubricating oil to prevent continued rust. Report it to your supervisor.
  - (3) **Steps, Walkways, Handholds.** Inspect steps, walkways, and handholds for condition and cleanliness. Report any loose, missing, or damaged components to your supervisor.
  - (4) **Bolts, Nuts, and Screws.** Check all bolts, nuts, and screws. If loose, missing, bent or broken either tighten or report condition to your supervisor.
  - (5) **Welds.** Look for loose or chipped paint, rust, or gaps where parts are welded together. If you find a damaged weld, report it to your supervisor.
  - (6) **Electrical Wire and Connectors.** Inspect for cracked, frayed, or broken insulation, bare wires, and loose or broken connectors. Report damage to your supervisor.
  - (7) **Clamps, Guards, Heatshields.** Ensure all clamps, guards, and heatshields are present and correctly installed. Report missing components to your supervisor.
  - (8) **Hoses and Fluid Lines.** Check for wear, damage and leaks. Wetness or a stain around seals, gaskets, fittings or connectors indicates leakage. If a fitting, clamp, or connector is loose, broken, or defective, report it. Use the FLUID LEAKAGE definitions to type/class leaks.
  - (9) **Data, Caution, Warning Plates.** Check data, caution, and warning plates for security and legibility. Report missing or damaged plates to your supervisor.
  - (10) **Fluid Checks.** Ensure Compactor is on level surface to get accurate fluid readings.

**OPERATOR PREVENTIVE MAINTENANCE CHECKS AND SERVICES  
FOR  
HIGH SPEED, SELF-PROPELLED, COMPACTOR**

| ITEM NO. | INTERVAL | ITEM TO BE CHECKED OR SERVICED | PROCEDURE   | NOT FULLY MISSION CAPABLE IF:  |
|----------|----------|--------------------------------|---|--|
| 1        | Before   | Left Front, Side Exterior      | <p style="text-align: center;"><b>WARNING</b></p> <p>Always read the WARNINGS, CAUTIONS, and NOTES before operating the compactor and prior to PMCS.</p> <p style="text-align: center;"><b>NOTE</b></p> <p>Perform your before, after, and weekly checks if:</p> <p>a. You are the assigned driver but have not operated the compactor since the last weekly inspection.</p> <p>b. You are operating the compactor for the first time.</p> <p style="text-align: center;"><b>WARNING</b></p> <p>Disconnect steering frame lock link and secure to retaining plates before operation or the compactor will not steer.</p> <p>Connect steering frame lock link between front and rear frames before lifting, transporting, or performing service near center of machine.</p> <p style="text-align: center;"><b>NOTE</b></p> <p>If leakage is detected, further investigation is needed to determine the location and cause of the leak.</p> <p>a. Visually check underneath compactor for evidence of fluid leakage.</p> <p>b. Visually check compactor for obvious damage that would impair operation.</p> | <p>a. Any fuel leak; class III leak of oil, brake, or coolant; or a steady stream of hydraulic oil.</p> <p>b. Any damage that would prevent operation.</p> |

**OPERATOR PREVENTIVE MAINTENANCE CHECKS AND SERVICES  
FOR  
HIGH SPEED, SELF-PROPELLED, COMPACTOR**

| ITEM NO. | INTERVAL | ITEM TO BE CHECKED OR SERVICED | PROCEDURE  | NOT FULLY MISSION CAPABLE IF:  |
|----------|----------|--------------------------------|--|--|
| 2        | Before   | Fuel Tank Drain Valve          | <p style="text-align: center;"><b>WARNING</b></p> <p>Do not open drain valve while smoking or near fire or sparks. Failure to comply may cause fuel to ignite and cause injury or death to personnel or damage equipment.</p> <p>a. Check fuel tank drain valve for leakage or damage.</p> <p>b. Open drain valve to drain water/sediment into suitable container. Dispose of fluids in accordance with local regulations.</p>   | <p>a. Evidence of valve leakage or valve damage.</p>   |
| 3        | Before   | Rear Exterior                  | <p style="text-align: center;"><b>NOTE</b></p> <p>If leakage is detected, further investigation is needed to determine the location and cause of the leak.</p> <p>a. Visually check underneath the compactor for evidence of fluid leakage.</p> <p>b. Visually check rear of compactor for obvious damage that would impair operation.</p>   | <p>a. Any fuel leak; class III leak of oil, brake, or coolant; or a steady stream of hydraulic oil.</p> <p>b. Any damage that would prevent operation.</p> |
| 4        | Before   | Cooling System                 | <p style="text-align: center;"><b>WARNING</b></p> <p>Use extreme care when removing radiator cap if temperature gage reads above 180°F (82°C). Contact by steam or hot coolant may result in injury or death to personnel.</p> <p>Use a clean, thick cloth to remove the radiator cap. Avoid using gloves, as hot water could soak through gloves and cause burns to personnel.</p> <p style="text-align: center;"><b>CAUTION</b></p> <p>Overheating, caused by lack of coolant, will cause engine damage.</p> |  |



**OPERATOR PREVENTIVE MAINTENANCE CHECKS AND SERVICES  
FOR  
HIGH SPEED, SELF-PROPELLED, COMPACTOR**

| ITEM NO. | INTERVAL | ITEM TO BE CHECKED OR SERVICED | PROCEDURE  | NOT FULLY MISSION CAPABLE IF:   |
|----------|----------|--------------------------------|--|---|
| 5        | Before   | Right Front, Side Exterior     | <p style="text-align: center;"><b>NOTE</b></p> <p>If it is necessary to add coolant daily, check for leaks.</p> <p>a. Check coolant level in sight gauge.</p> <p>b. If coolant is added, inspect cap and seal for damage or debris. Clean or replace if needed.</p> <p style="text-align: center;"><b>NOTE</b></p> <p>If leakage is detected, further investigation is needed to determine the location and cause of the leak.</p> <p>a. Visually check underneath compactor for evidence of fluid leakage.</p> <p>b. Visually check front and right side of compactor for obvious damage that would impair operation.</p> | <p>a. Coolant level is below "ADD" mark.</p> <p>a. Any fuel leak; class III leak of oil, brake, or coolant; or a steady stream of hydraulic oil.</p> <p>b. Any damage that would prevent operation.</p> |
| 6        | Before   | Hydraulic Oil Sight Gauge      | <p style="text-align: center;"><b>WARNING</b></p> <p>If equipment has been recently operated, do not remove hydraulic oil filler cap until it is cool enough to remove with your bare hands.</p> <p style="text-align: center;"><b>CAUTION</b></p> <p>Do not permit dirt, dust, or grit to enter hydraulic oil fill tube. Damage could result if hydraulic oil becomes contaminated.</p> <p>Check hydraulic oil level in sight gauge.</p>  | <p>Hydraulic oil is not between "ADD" and "FULL" mark.</p>  |
| 7        | Before   | Mirrors                        | <p>Check mirrors for presence, cracks, and serviceability.</p>   | <p>Mirrors missing or unserviceable.</p>  |

**OPERATOR PREVENTIVE MAINTENANCE CHECKS AND SERVICES  
FOR  
HIGH SPEED, SELF-PROPELLED, COMPACTOR**

| ITEM NO. | INTERVAL | ITEM TO BE CHECKED OR SERVICED | PROCEDURE   | NOT FULLY MISSION CAPABLE IF:   |
|----------|----------|--------------------------------|---|---|
| 8        | Before   | Seat and Seatbelts             | <p style="text-align: center;"><b>NOTE</b></p> <p>Seat belts must be replaced regardless of condition after 3 years of use.</p> <p>a. Check seatbelt and mounting hardware for damage, and operation of buckle and clasp ends.</p> <p>b. Check operation of seat adjustment.</p>  | <p>a. Seatbelt damaged or missing.</p> <p>b. Seat adjustment inoperable or damaged.</p> |
| 9        | During   | Monitoring System and Gauges   | <p style="text-align: center;"><b>WARNING</b></p> <p>If monitoring system alert indicator, action light and action alarm activate at the same time</p> <p style="text-align: center;">OR</p> <p>If alert indicator and/or action light remain activated, after an attempt to correct the problem/ failure has been made</p> <p><b>IMMEDIATELY SHUT DOWN THE SYSTEM</b> and notify supervisor or unit maintenance. Continued operation may result in injury or damage to equipment.</p> <p style="text-align: center;"><b>NOTE</b></p> <p>Ensure the steering lock link is stored in the unlocked position.</p> <p><b>START THE ENGINE IAW ENGINE STARTING PROCEDURES.</b></p> <p style="text-align: center;"><b>NOTE</b></p> <p>Monitoring system will perform automatic self-test.</p> <p>Inspect gauge panel and monitoring system for damage, unserviceable instruments and broken glass. Monitor instrument panel regularly for proper function of all systems.</p> <p>a. Engine coolant temperature gauge.</p> | <p>a. Indicator reads in red area.</p>  |

**OPERATOR PREVENTIVE MAINTENANCE CHECKS AND SERVICES  
FOR  
HIGH SPEED, SELF-PROPELLED, COMPACTOR**

| ITEM NO. | INTERVAL | ITEM TO BE CHECKED OR SERVICED    | PROCEDURE  | NOT FULLY MISSION CAPABLE IF:   |
|----------|----------|-----------------------------------|--|---|
| 10       | During   | Work, Panel, and Indicator Lights | b. Transmission oil temperature gauge.<br>c. Hydraulic oil temperature gauge.<br><br>Check for broken or inoperable lights.  | b. Indicator reads in red area.<br>c. Indicator reads in red area.<br><br>During night operation, work lights inoperable. |
| 11       | During   | Back-up Alarm                     | <p style="text-align: center;"><b>NOTE</b></p> Switch should be set on high during normal operation.<br><br>Ensure manual override switch is disengaged. Apply service brake. Shift into reverse. Alarm should sound and continue to sound until transmission is moved out of reverse.   | Back-up alarm fails to sound.   |
| 12       | During   | Horn                              | Sound horn.  | Horn fails to sound.  |
| 13       | During   | Brakes                            | Monitor brake system for sufficient stopping capability.   | Brakes slip, require excessive pedal force, or brake application is not smooth.   |
| 14       | During   | Steering                          | Monitor steering response and/or unstable handling.  | Unstable handling, excessive free play, or binding.   |
| 15       | During   | Transmission                      | Monitor transmission for proper operation.   | Transmission slips or will not shift.   |
| 16       | After    | Filter Elements                   | <p style="text-align: center;"><b>WARNING</b></p> If NBC exposure is suspected, personnel wearing protective equipment should handle all air filter media. Consult your unit NBC Officer or NBC NCO for appropriate handling or disposal instructions.<br><br><p style="text-align: center;"><b>WARNING</b></p> Service of the air cleaner must be performed with the engine stopped. Damage to the engine could result.<br><br><p style="text-align: center;"><b>NOTE</b></p> Always replace secondary element. Never attempt to reuse by cleaning. |   |

**OPERATOR PREVENTIVE MAINTENANCE CHECKS AND SERVICES  
FOR  
HIGH SPEED, SELF-PROPELLED, COMPACTOR**

| ITEM NO. | INTERVAL | ITEM TO BE CHECKED OR SERVICED | PROCEDURE  | NOT FULLY MISSION CAPABLE IF:                             |
|----------|----------|--------------------------------|--|---|
| 17       | After    | Light Switches                 | <p>With the engine running at high idle check the filter element indicator. Clean or replace air filters as required.</p> <p style="text-align: center;"><b>NOTE</b></p> <p>Ensure all switches are in the "OFF" position. Failure to turn switches to the "OFF" position when not in use will drain the battery.</p> <p>a. Ensure that all light switches are in the "OFF" position.</p>  | The yellow piston moves into the red zone.                |
| 18       | After    | Transmission Oil               | <p style="text-align: center;"><b>CAUTION</b></p> <p>Do not permit dirt, dust, or grit to enter transmission oil dipstick tube. Internal transmission damage will result if transmission oil becomes contaminated.</p> <p style="text-align: center;"><b>NOTE</b></p> <p>Check fluids/oils with equipment on level ground. Lower the blade to the ground with slight down pressure and engage the parking/ secondary brake.</p> <p style="text-align: center;"><b>NOTE</b></p> <p>Use Caterpillar oil, part number (11083) 2P9869.</p> <p>a. Open the transmission access cover. Check the transmission oil level on the dipstick.</p> <p>b. If transmission oil is added, inspect cap and seal for damage or debris. Clean or replace if needed.</p> <p style="text-align: center;">TURN ENGINE OFF IAW ENGINE STOPPING PROCEDURES.</p> | a. Transmission oil is not between "ADD" and "FULL" mark. |
| 19       | After    | Engine Oil                     | <p style="text-align: center;"><b>WARNING</b></p> <p>Engine oil is hot. Oils can burn when in contact with very hot surfaces or if ignited when re-released as a spray. Keep ignition sources away. Provide</p>  |   |

**OPERATOR PREVENTIVE MAINTENANCE CHECKS AND SERVICES  
FOR  
HIGH SPEED, SELF-PROPELLED, COMPACTOR**

| ITEM NO. | INTERVAL | ITEM TO BE CHECKED OR SERVICED | PROCEDURE  | NOT FULLY MISSION CAPABLE IF:                           |
|----------|----------|--------------------------------|--|---|
|          |          |                                | adequate ventilation. Wear protective clothing/equipment.  |   |
|          |          |                                | <b>CAUTION</b><br>Engine oil level can be measured with the engine operation either stopped or running. Ensure measurement is taken from the side of the dipstick that corresponds with engine operation. DO NOT overfill crankcase. Engine damage could result. |   |
|          |          |                                | a. Open the engine oil access cover. Check the engine oil level on the dipstick.   | a. Engine oil is below "ADD" mark.                      |
| 20       | After    | Dozer Control Linkage          | Inspect dozer control linkage for damage or excessive wear.  | Missing or loose bolts, cracked cap or link.            |
| 21       | After    | Battery Disconnect Switch      | <b>NOTE</b><br>Never turn the disconnect key to OFF with the engine running. Electrical system damage could result.  |   |
|          |          |                                | When parking the compactor for an extended period of time, turn the battery disconnect switch key to the "OFF" position and remove the key.  |   |
| 22       | After    | Engine Compartment             | Inspect and remove debris from the engine compartment.   |   |
| 23       | Weekly   | Fan and Alternator Belts       | Check the fan and alternator belts for fraying and cracks.   | Fan and/or alternator belts frayed, cracked or missing. |
| 24       | Weekly   | Cooling System                 | a. Check radiator core for debris/obstructions. Remove foreign material.<br><br>b. Check for bent radiator fins and/or damaged fan blades.   | b. Bent radiator fins and/or damaged fan blades.        |
| 25       | Weekly   | Tamping Tips                   | Inspect the tamping tips for wear.   | Tamping tips worn through the wear                      |

**OPERATOR PREVENTIVE MAINTENANCE CHECKS AND SERVICES  
FOR  
HIGH SPEED, SELF-PROPELLED, COMPACTOR**

| ITEM NO. | INTERVAL | ITEM TO BE CHECKED OR SERVICED    | PROCEDURE   | NOT FULLY MISSION CAPABLE IF:  |
|----------|----------|-----------------------------------|---|--|
| 26       | Weekly   | Cutting Edge and End Bits         | Inspect cutting edge and end bits for wear or damage.   | cavity.<br>Loose, cracked or missing cutting edge or end bits. Cutting edge worn to approx. ½ inch of blade. |
| 27       | Weekly   | Dozer Blade Assembly              | Inspect blade, cylinder, push arms and attachments for wear or damage.  | Loose cracked or missing components /hardware.   |
| 28       | Weekly   | Cleaning Bar and Scraper Tips     | Visually check distance between scraper tip edges and the wheel.  | Clearance between scraper tip edges and wheel reaches approx. 1 inch.  |
| 29       | Weekly   | Rollover Protection System (ROPS) | Inspect ROPS for loose, damaged, or missing bolts; check for cracks in welds, castings, and any structural damage.  | Loose, damaged or missing hardware, any cracks or other structural damage.                                   |
| 30       | Monthly  | Exhaust System                    | Inspect muffler and pipes for damage, or loose or damaged hardware.   | Any damage that allows exhaust leaks. Loose, missing, or damaged hardware.                                   |
| 31       | Monthly  | Batteries                         | <p style="text-align: center;"><b>WARNING</b></p> <p>Don't smoke, have open flames, or make sparks around batteries, especially if caps are removed. Batteries can explode and cause injure or death.</p> <p>Remove all jewelry such as rings, dog tags, bracelets, etc. If jewelry contacts battery terminal, a direct short will result, causing severe injury to personnel or damage to equipment.</p> <p>a. Open battery access covers.</p> <p>b. Check electrolyte level. Electrolyte should be maintained within one-quarter inch of the bottom of the filler tubes. If fluid is low fill with distilled or clean drinking to the appropriate level.</p> <p>c. Inspect battery terminals and cables for corrosion. Check battery cables for security.</p> | <p>b. Batteries missing, unserviceable, or leaking.</p> <p>c. Battery or terminals loose or</p>              |

**OPERATOR PREVENTIVE MAINTENANCE CHECKS AND SERVICES  
FOR  
HIGH SPEED, SELF-PROPELLED, COMPACTOR**

| ITEM NO. | INTERVAL | ITEM TO BE CHECKED OR SERVICED | PROCEDURE  | NOT FULLY MISSION CAPABLE IF:  |
|----------|----------|--------------------------------|--|--|
| 32       | Monthly  | Fuel Tank Cap                  | <p>Clean the battery surface with a clean cloth.</p> <p>d. Check battery hold downs and hardware for presence or damage.</p>   | <p>corroded. Notify Unit maintenance.</p> <p>d. Battery hold downs or hardware missing or unserviceable.</p>                                     |
| 33       | Monthly  | Service & Parking Brakes       | <p>Inspect the fuel cap for presence and damage.</p> <p style="text-align: center;"><b>WARNING</b></p> <p>Personal injury may result if compactor moves during brake test. If compactor begins to move during either test, reduce engine speed and immediately apply the alternate brake system.</p> <p style="text-align: center;"><b>WARNING</b></p> <p>Fasten seatbelts before testing brakes.</p> <p style="text-align: center;"><b>CAUTION</b></p> <p>Ensure area around compactor is clear of personnel and obstructions.</p> <p style="text-align: center;"><b>NOTE</b></p> <p>Test brakes on dry level surface.</p> <p>a. Slightly raise dozer blade.</p> <p>b. SERVICE BRAKE TEST. Apply service brake and release parking brake. Shift to second speed forward. Gradually increase speed to high idle. Reduce engine speed to NEUTRAL. Engage parking brake.</p> <p style="text-align: center;"><b>NOTE</b></p> <p>Both the parking brake alert and the action alarm should activate.</p> <p>c. PARKING BRAKE TEST. With parking brake engaged, move transmission to second speed REVERSE. Gradually increase engine speed to high idle.</p> | <p>Fuel cap missing, seal damaged.</p> <p>b. Compactor moves during service brake test.</p> <p>c. Compactor moves during parking brake test.</p> |
| 34       | Monthly  | Brake Accumulator              | <p>a. Turn the engine start switch to ON. The brake oil pressure indicator light should come on if not at normal operating pressure.</p>   | <p>a. Brake oil pressure light fails to go off.</p>  |

**OPERATOR PREVENTIVE MAINTENANCE CHECKS AND SERVICES  
FOR  
HIGH SPEED, SELF-PROPELLED, COMPACTOR**

| ITEM NO. | INTERVAL | ITEM TO BE CHECKED OR SERVICED | PROCEDURE  | NOT FULLY MISSION CAPABLE IF:   |
|----------|----------|--------------------------------|--|---|
|          |          |                                | <p>Start and run the engine at half speed for 2 minutes. The brake oil pressure light should go off. STOP THE ENGINE.</p> <p>b. Apply and release the service brake pedal until the brake oil pressure light comes on.</p> | <p>b. Brake oil pressure light comes on in LESS than 5 applications of the brake pedal.</p> |



RECOMMENDED CHANGES TO EQUIPMENT PUBLICATIONS



THEN - JOT DOWN THE INFO ON THIS FORM—TEAR OUT THIS PAGE—FOLD IT—AND DROP IT IN THE MAIL!

SOMETHING WRONG WITH THIS PUBLICATION?

FROM: (IMPRINT YOUR UNIT'S COMPLETE ADDRESS)

DATE SENT:

PUBLICATION NUMBER

TM 5-3805-380-10

PUBLICATION DATE

12 August 1999

PUBLICATION TITLE

HIGH SPEED COMPACTOR, MODEL 815F

BE EXACT...PINPOINT WHERE IT IS

| PAGE NO. | PARA-GRAPH | FIGURE NO. | TABLE NO. |
|----------|------------|------------|-----------|
| 1-3      | 1-6        |            |           |
| 3-1      | 3-3        |            |           |
| 3-18     | 3-10       |            |           |

IN THIS SPACE, TELL WHAT IS WRONG AND WHAT SHOULD BE DONE ABOUT IT:

Suck unit illustration shows suction hose item = 3 as two hoses coupled together. Reason: suction hose is now one hose.

Text refers to cleaning solvent item 7, App. D in Expandable Supplies Section. Reason: Should be item 10, App. D.

Blender hose illustration is not accurate as shown. Reason: Blender hose should show quick-disconnect couplings at both ends.

**SAMPLE**

PRINTED NAME, GRADE OR TITLE, AND TELEPHONE NUMBER

SSG. TED RYBA 671-3681

SIGN HERE:

*SSG Ted Ryba*

DA FORM 2028-2  
1 JUL 79

PREVIOUS EDITIONS ARE OBSOLETE.

P.S. IF YOUR OUTFIT WANTS TO KNOW ABOUT YOUR RECOMMENDATION, MAKE A CARBON COPY OF THIS AND GIVE IT TO YOUR HEADQUARTERS.

TEAR ALONG PERFORATED LINE

FILL IN YOUR  
UNIT'S ADDRESS



FOLD BACK

DEPARTMENT OF THE ARMY



OFFICIAL BUSINESS

NO POSTAGE  
NECESSARY  
IF MAILED  
IN THE  
UNITED STATES

**BUSINESS REPLY MAIL**

FIRST CLASS

BRM PERMIT NO. 82

ROCK ISLAND, IL

POSTAGE WILL BE PAID BY ROCK ISLAND ARSENAL

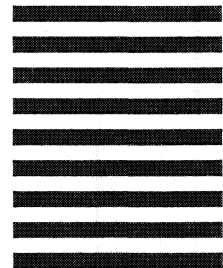

HQ, US ARMY TANK-AUTOMOTIVE AND  
ARMAMENTS COMMAND  
ATTN: AMSTA-LC-CI (TECH PUBS CONTROL POINT)  
ROCK ISLAND, IL 61201-9948

TEAR ALONG PERFORATED LINE





THEN... JOT DOWN THE DOPE ABOUT IT ON THIS FORM. CAREFULLY TEAR IT OUT. FOLD IT AND DROP IT IN THE MAIL!

# SOMETHING WRONG WITH THIS PUBLICATION?

FROM: (PRINT YOUR UNIT'S COMPLETE ADDRESS)

DATE SENT

PUBLICATION NUMBER

TM 5-3805-380-10

PUBLICATION DATE

12 August 1999

PUBLICATION TITLE

HIGH SPEED  
COMPACTOR, MODEL 815F

BE EXACT... PIN-POINT WHERE IT IS

PAGE  
NO

PARA-  
GRAPH

FIGURE  
NO

TABLE  
NO

IN THIS SPACE TELL WHAT IS WRONG  
AND WHAT SHOULD BE DONE ABOUT IT:

PRINTED NAME, GRADE OR TITLE, AND TELEPHONE NUMBER

SIGN HERE:

FILL IN YOUR  
UNIT'S ADDRESS



FOLD BACK

TEAR ALONG PERFORATED LINE

DEPARTMENT OF THE ARMY



OFFICIAL BUSINESS

NO POSTAGE  
NECESSARY  
IF MAILED  
IN THE  
UNITED STATES

**BUSINESS REPLY MAIL**

FIRST CLASS

BRM PERMIT NO. 82

ROCK ISLAND, IL

POSTAGE WILL BE PAID BY ROCK ISLAND ARSENAL

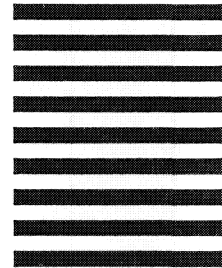

HQ, US ARMY TANK-AUTOMOTIVE AND  
ARMAMENTS COMMAND  
ATTN: AMSTA-LC-CI (TECH PUBS CONTROL POINT)  
ROCK ISLAND, IL 61201-9948





THEN... JOT DOWN THE DOPE ABOUT IT ON THIS FORM. CAREFULLY TEAR IT OUT. FOLD IT AND DROP IT IN THE MAIL!

# SOMETHING WRONG WITH THIS PUBLICATION?

FROM: (PRINT YOUR UNIT'S COMPLETE ADDRESS)

DATE SENT

PUBLICATION NUMBER

TM 5-3805-380-10

PUBLICATION DATE

12 August 1999

PUBLICATION TITLE HIGH SPEED

COMPACTOR, MODEL 815F

BE EXACT... PIN-POINT WHERE IT IS

PAGE NO

PARA-GRAPH

FIGURE NO

TABLE NO

IN THIS SPACE TELL WHAT IS WRONG AND WHAT SHOULD BE DONE ABOUT IT:

PRINTED NAME, GRADE OR TITLE, AND TELEPHONE NUMBER

SIGN HERE:

FILL IN YOUR  
UNIT'S ADDRESS



FOLD BACK

DEPARTMENT OF THE ARMY



OFFICIAL BUSINESS

NO POSTAGE  
NECESSARY  
IF MAILED  
IN THE  
UNITED STATES

**BUSINESS REPLY MAIL**

FIRST CLASS

BRM PERMIT NO. 82

ROCK ISLAND, IL

POSTAGE WILL BE PAID BY ROCK ISLAND ARSENAL

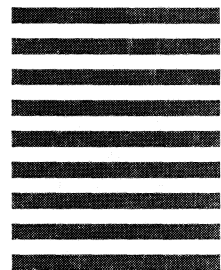

HQ, US ARMY TANK-AUTOMOTIVE AND  
ARMAMENTS COMMAND  
ATTN: AMSTA-LC-CI (TECH PUBS CONTROL POINT)  
ROCK ISLAND, IL 61201-9948

TEAR ALONG PERFORATED LINE





THEN... JOT DOWN THE DOPE ABOUT IT ON THIS FORM. CAREFULLY TEAR IT OUT. FOLD IT AND DROP IT IN THE MAIL!

# SOMETHING WRONG WITH THIS PUBLICATION?

FROM: (PRINT YOUR UNIT'S COMPLETE ADDRESS)

DATE SENT

PUBLICATION NUMBER

TM 5-3805-380-10

PUBLICATION DATE

12 August 1999

PUBLICATION TITLE

HIGH SPEED COMPACTOR, MODEL 815F

BE EXACT... PIN-POINT WHERE IT IS

| PAGE NO | PARA-GRAPH | FIGURE NO | TABLE NO |
|---------|------------|-----------|----------|
|         |            |           |          |

IN THIS SPACE TELL WHAT IS WRONG AND WHAT SHOULD BE DONE ABOUT IT:

PRINTED NAME, GRADE OR TITLE, AND TELEPHONE NUMBER

SIGN HERE:

FILL IN YOUR UNIT'S ADDRESS



FOLD BACK

TEAR ALONG PERFORATED LINE

DEPARTMENT OF THE ARMY



OFFICIAL BUSINESS

NO POSTAGE  
NECESSARY  
IF MAILED  
IN THE  
UNITED STATES

**BUSINESS REPLY MAIL**

FIRST CLASS

BRM PERMIT NO. 82

ROCK ISLAND, IL

POSTAGE WILL BE PAID BY ROCK ISLAND ARSENAL

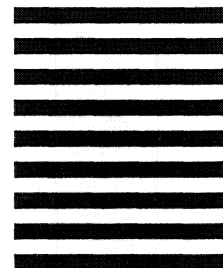

HQ, US ARMY TANK-AUTOMOTIVE AND  
ARMAMENTS COMMAND  
ATTN: AMSTA-LC-CI (TECH PUBS CONTROL POINT)  
ROCK ISLAND, IL 61201-9948





By Order of the Secretary of the Army:

ERIC K. SHINSEKI  
*General, United States Army*  
*Chief of Staff*

Official:

  
JOEL B. HUDSON  
*Administrative Assistant to the*  
*Secretary of the Army*  
9921703

DISTRIBUTION: To be distributed in accordance with the initial distribution number (IDN)  
256537, requirements for TM 5-3805-380-10.

10/10/2005  
10/10/2005

10/10/2005

10/10/2005

10/10/2005

## THE METRIC SYSTEM AND EQUIVALENTS

|  |   |
|--|---|
| <p><b>Linear Measure</b></p> <p>1 Centimeter = 10 Millimeters = 0.01 Meters = 0.3937 Inches<br/>         1 Meter = 100 Centimeters = 1000 Millimeters = 39.37 Inches<br/>         1 Kilometer = 1000 Meters = 0.621 Miles</p> <p><b>Weights</b></p> <p>1 Gram = 0.001 Kilograms = 1000 Milligrams = 0.035 Ounces<br/>         1 Kilogram = 1000 Grams = 2.2 Pounds<br/>         1 Metric Ton = 1000 Kilograms = 1 Megagram = 1.1 Short Tons</p> <p><b>Liquid Measure</b></p> <p>1 Milliliter = 0.001 Liters = 0.0338 Fluid Ounces<br/>         1 Liter = 1000 Milliliters = 33.82 Fluid Ounces</p> | <p><b>Square Measure</b></p> <p>1 Sq Centimeter = 100 Sq Millimeters = 0.155 Sq Inches<br/>         1 Sq Meter = 10,000 Sq Centimeters = 10.76 Sq Feet<br/>         1 Sq Kilometer = 1,000,000 Sq Meters = 0.386 Sq Miles</p> <p><b>Cubic Measure</b></p> <p>1 Cu Centimeter = 1,000 Cu Millimeters = 0.06 Cu Inches<br/>         1 Cu Meter = 1,000,000 Cu Centimeters = 35.31 Cu Feet</p> <p><b>Temperature</b></p> <p><math>9/5 C^{\circ} + 32 = F^{\circ}</math><br/> <math>5/9 (F^{\circ} - 32) = C^{\circ}</math><br/>         212° Fahrenheit is equivalent to 100° Celsius<br/>         90° Fahrenheit is equivalent to 32.2° Celsius<br/>         32° Fahrenheit is equivalent to 0° Celsius</p> |
|--|---|

## APPROXIMATE CONVERSION FACTORS

| To Change          | To                   | Multiply By |
|--------------------|----------------------|-------------|
| Inches             | Centimeters          | 2.540       |
| Feet               | Meters               | 0.305       |
| Yards              | Meters               | 0.914       |
| Miles              | Kilometers           | 1.609       |
| Sq Inches          | Sq Centimeters       | 6.451       |
| Sq Feet            | Sq Meters            | 0.093       |
| Sq Yards           | Sq Meters            | 0.836       |
| Sq Miles           | Sq Kilometers        | 2.590       |
| Acres              | Sq Hectometers       | 0.405       |
| Cubic Feet         | Cubic Meters         | 0.028       |
| Cubic Yards        | Cubic Meters         | 0.765       |
| Fluid Ounces       | Milliliters          | 29.573      |
| Pints              | Liters               | 0.473       |
| Quarts             | Liters               | 0.946       |
| Gallons            | Liters               | 3.785       |
| Ounces             | Grams                | 28.349      |
| Pounds             | Kilograms            | 0.454       |
| Short Tons         | Metric Tons          | 0.907       |
| Pound-Feet         | Newton-Meters        | 1.356       |
| Pounds per Sq Inch | Kilopascals          | 6.895       |
| Miles per Gallon   | Kilometers per Liter | 0.425       |
| Miles per Hour     | Kilometers per Hour  | 1.609       |

| To Change            | To                 | Multiply By |
|----------------------|--------------------|-------------|
| Centimeters          | Inches             | 0.394       |
| Meters               | Feet               | 3.280       |
| Meters               | Yards              | 1.094       |
| Kilometers           | Miles              | 0.621       |
| Sq Centimeters       | Sq Inches          | 0.155       |
| Sq Meters            | Sq Feet            | 10.764      |
| Sq Meters            | Sq Yards           | 1.196       |
| Sq Kilometers        | Sq Miles           | 0.386       |
| Sq Hectometers       | Acres              | 2.471       |
| Cubic Meters         | Cubic Feet         | 35.315      |
| Cubic Meters         | Cubic Yards        | 1.308       |
| Milliliters          | Fluid Ounces       | 0.034       |
| Liters               | Pints              | 2.113       |
| Liters               | Quarts             | 1.057       |
| Liters               | Gallons            | 0.264       |
| Grams                | Ounces             | 0.035       |
| Kilograms            | Pounds             | 2.205       |
| Metric Tons          | Short Tons         | 1.102       |
| Newton-Meters        | Pound-Feet         | 0.738       |
| Kilopascals          | Pounds per Sq Inch | 0.145       |
| Kilometers per Liter | Miles per Gallon   | 2.354       |
| Kilometers per Hour  | Miles per Hour     | 0.621       |

